

Remote Switch Mechanism

KASTA-1BMBH-W



Smart push button remote switch mechanism that clips into standard wall plate

FEATURES

- Reliable Bluetooth® mesh network connectivity for control of all your KASTA devices
- 2-wire connection for mains power
- Slim design allows installation up to 6 onto a standard wall plate
- Short press for ON/OFF control
- Long press for dimming control (where KASTA dimming devices are used)
- Supports core KASTA functionality - control devices, groups, scenes, timers and scheduling
- Suits most Australian wall plates
- Supplied with White button caps (2 x styles)
- iOS and Android app setup and control
- 3 year warranty

SPECIFICATIONS

Power Supply	220-240V a.c. 50Hz
Operating Ambient Temperature	-20 to 40°C
IP Rating	IP20
Physical Connection Type	Fly leads
Wiring Connections	Active & Neutral
Housing Material	Polycarbonate (PC)
LED Indicators	Blue
Standards Complied	AS/NZS 60950.1, AS/NZS CISPR 15, AS/NZS 4268

DIMENSIONS

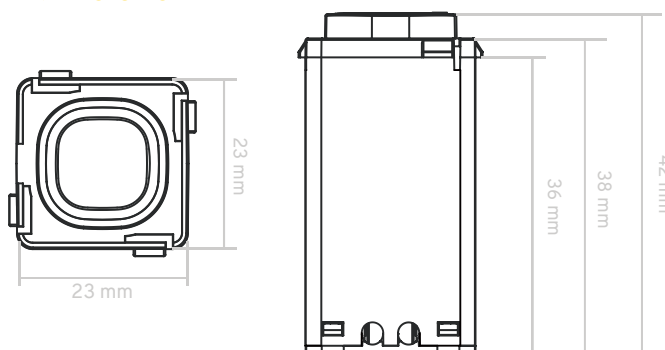

CONNECTION

