

# ABB i-bus<sup>®</sup> KNX SA/S Switch Actuators Product Manual



## Contents

Page

<b>1</b>	<b>General .....</b>	<b>5</b>
1.1	Using the product manual.....	5
1.1.1	Structure of the product manual .....	6
1.1.2	Notes .....	6
1.2	Product and functional overview.....	7
<b>2</b>	<b>Device technology .....</b>	<b>9</b>
2.1	Switch Actuators SA/S x.6.1.1, 6 A, MDRC .....	9
2.1.1	Technical data .....	9
2.1.2	Lamp output load at 230 V AC .....	11
2.1.3	Connection schematic SA/S x.6.1.1 .....	12
2.1.4	Dimension drawing SA/S x.6.1.1 .....	13
2.2	Switch Actuators SA/S x.6.2.1, 6 A, manual, MDRC.....	14
2.2.1	Technical data .....	14
2.2.2	Lamp output load, 6 A.....	16
2.2.3	Connection schematic SA/S x.6.2.1 .....	17
2.2.4	Dimension drawing SA/S x.6.2.1 .....	18
2.3	Switch Actuators SA/S x.10.2.1, 10 A, MDRC .....	19
2.3.1	Technical data .....	19
2.3.2	Lamp output load 10 A.....	21
2.3.3	Connection schematic SA/S x.10.2.1 .....	22
2.3.4	Dimension drawing SA/S x.10.2.1 .....	23
2.4	Switch Actuators SA/S x.16.2.1, 16 A MDRC .....	24
2.4.1	Technical data .....	24
2.4.2	Lamp output load 16 A.....	26
2.4.3	Connection schematic SA/S x.16.2.1 .....	27
2.4.4	Dimension drawing SA/S x.16.2.1 .....	28
2.5	Switch Actuator SA/S 16.5.1, 16/20 A, MDRC.....	29
2.5.1	Technical data .....	29
2.5.2	Lamp output load 16/20 A.....	31
2.5.3	Connection schematic SA/S 12.16.5.1 .....	32
2.5.4	Dimension drawing SA/S 12.16.5.1 .....	33
2.6	Switch Actuators SA/S x.16.6.1, 16/20 A, MDRC .....	34
2.6.1	Technical data .....	34
2.6.2	Lamp output load 16/20 A.....	36
2.6.3	Connection schematic SA/S x.16.6.1 .....	39
2.6.4	Dimension drawing SA/S x.16.6.1 .....	40
2.7	Overview of switching performance.....	41
2.8	Ballast calculation.....	42
2.9	AC1, AC3, AX, C-load specifications.....	43
2.10	Current detection specifications.....	44
2.11	Assembly and installation .....	47

<b>3</b>	<b>Commissioning .....</b>	<b>49</b>
3.1	Overview .....	50
3.1.1	Conversion of previous application program versions .....	53
3.1.1.1	Conversion options .....	53
3.1.1.1.1	Summary of conversion .....	55
3.1.1.1.2	Procedure .....	56
3.1.2	Copying and exchanging parameter settings .....	57
3.1.2.1	Procedure .....	58
3.1.2.2	Copy/Exchange channels dialog .....	59
3.2	Parameters .....	61
3.2.1	Parameter window <i>General</i> .....	62
3.2.2	Parameter window A: <i>General</i> .....	66
3.2.3	Operating mode <i>Switch Actuator</i> .....	67
3.2.3.1	Parameter window A: <i>Function</i> .....	71
3.2.3.1.1	Parameter window A: <i>Time</i> .....	76
3.2.3.1.2	Parameter window A: <i>Preset</i> .....	86
3.2.3.1.3	Parameter window A: <i>Scene</i> .....	89
3.2.3.1.4	Parameter window A: <i>Logic</i> .....	91
3.2.3.1.5	Parameter window A: <i>Safety</i> .....	94
3.2.3.1.6	Parameter window A: <i>Threshold</i> .....	98
3.2.3.1.7	Parameter window A: <i>Current Detection</i> .....	101
3.2.4	Communication objects, operating mode <i>Switch Actuator</i> .....	109
3.2.4.1	Communication objects, <i>General</i> .....	109
3.2.4.2	Communication objects, <i>Output A</i> .....	111
3.2.5	Operating mode <i>Heating Actuator</i> .....	119
3.2.5.1	Parameter window A: <i>Function</i> .....	124
3.2.5.1.1	Parameter window A: <i>"Monitoring"</i> .....	127
3.2.5.1.2	Parameter window A: <i>Forced Operation</i> .....	129
3.2.5.1.3	Parameter window A: <i>Valve Purge</i> .....	130
3.2.5.1.4	Parameter window A: <i>Current Detection</i> .....	132
3.2.6	Communications objects, operating mode <i>Heating Actuator</i> .....	133
3.2.6.1	Communication objects, <i>General</i> .....	133
3.2.6.2	Communication objects, <i>Output A</i> .....	135

<b>4</b>	<b>Planning and application .....</b>	<b>141</b>
4.1	Current detection .....	141
4.1.1	Threshold function with current detection .....	142
4.1.2	Operating state displays .....	143
4.1.3	Recording operating hours .....	144
4.1.4	Trend analysis .....	145
4.2	Operating mode <i>Switch Actuator</i> .....	147
4.2.1	Function diagram .....	147
4.2.2	Time function .....	148
4.2.2.1	Staircase lighting .....	148
4.2.2.2	ON/OFF delay .....	151
4.2.2.3	Flashing .....	152
4.2.3	Logic function .....	153
4.2.4	Preset function .....	155
4.2.5	Scene function .....	156
4.2.6	Threshold function .....	159
4.3	Operating mode <i>Heating Actuator</i> .....	161
4.3.1	Function diagram .....	161
4.3.2	2-step control .....	162
4.3.3	Pulse width modulation (PWM) .....	163
4.3.4	Pulse width modulation – calculation .....	164
4.3.5	Lifetime examination of a PWM control .....	165
4.4	Reaction on bus voltage failure, recovery and download .....	166
<b>A</b>	<b>Appendix .....</b>	<b>171</b>
A.1	Scope of delivery .....	171
A.2	Code table, 8 bit scene .....	171
A.3	Ordering details .....	173



## 1 General

KNX systems provide an attractive solution that meets the most demanding residential, commercial and public buildings requirements. High living standards, comfort and safety can be easily combined with cost-effectiveness and environmental awareness using KNX bus systems from ABB. KNX products cover the entire range of buildings applications, from illumination and blind control to heating, ventilation, energy management, security and surveillance. These requirements can be met cost-effectively with minimal planning and installation effort using the ABB KNX. Furthermore, flexible room usage and continuous adaptation to changing requirements are simple to implement. SA/S Switch Actuators fulfill individual requirements in industrial, commercial and public buildings as well as in the private sector for controlling switchable loads, e.g.:

- Illumination
- Heating control
- Signaling equipment

Certain types of Switch Actuator can also detect and monitor load current via a threshold value function. Based on the load current detected, responses can be triggered via KNX and the load can be switched off directly or switched via KNX.

### 1.1 Using the product manual

This manual provides you with detailed technical information on the ABB i-bus<sup>®</sup> SA/S Switch Actuator range, its installation and programming. Application of the device is explained using examples.

This manual is subdivided into the following sections:

Section 1	General
Section 2	Device technology
Section 3	Commissioning
Section 4	Planning and application
Section A	Appendix

## 1.1.1 Structure of the product manual

All parameters are described in section 3.

### Please note

This product manual describes all the current 2/4/8 and 12-fold Switch Actuators. However, as the functions for all outputs are identical, only the functions of output A will be described.

Where information in the product manual refers to all outputs, the description output A...X is used. 2-fold corresponds to outputs A...B, 4-fold corresponds to outputs A...D, 8-fold corresponds to outputs A...H and 12-fold corresponds to outputs A...L.

Variants with current detection feature an additional parameter page as well as additional communication objects for this function.

## 1.1.2 Notes

Notes and safety instructions are represented as follows in this product manual:

### Please note

Tips for usage and operation

### Example

Application examples, installation examples, programming examples

### Important

These safety instructions are used as soon as there is danger of a malfunction without risk of damage or injury.

### Caution

These safety instructions are used if there is a danger of damage with inappropriate use.



### Danger

These safety instructions are used if there is a danger to life and limb with inappropriate use.



### Danger

These safety instructions are used if there is an extreme danger to life with inappropriate use.



## 1.2 Product and functional overview



S/S 12.16.6.1



S/S 8.16.6.1



S/S 4.16.2.1



S/S 2.10.2.1



S/S 8.6.2.1



S/S 8.6.1.1



S/S 4.6.1.1

ABB i-bus<sup>®</sup> KNX SA/S Switch Actuators are modular installation devices with module widths of 2/4/8/12 units in ProM design for installation in a distribution board.

Connection to the ABB i-bus<sup>®</sup> is established via a bus connection terminal on the front. The Switch Actuators require no auxiliary voltage.

The assignment of the physical address as well as the parameterization is carried out with Engineering Tool Software (ETS), version ETS2 V1.3a or higher. If using ETS3 or ETS4 you will need to import the corresponding application program.

### Please note

The illustrations of the parameter windows in this manual correspond to the ETS3 parameter windows. The user program is optimized for ETS3.

In ETS2 the parameter page for any parameter being used may split automatically.

The Switch Actuators can switch 2 to 12 independent electrical AC or three-phase loads via KNX with floating contacts. With SA/S x.16.6.1 types it is possible to detect the load current for each output. The outputs of the 6 A, 10 A, 16 A and 16/20 A Switch Actuators can be switched on and off manually.

Switch Actuators SA/S x.16.6.1 and SA/S 12.16.5.1, which have the highest switching capacity (C-load), are particularly well-suited for switching loads with high peak inrush currents, e.g. lighting equipment with compensation capacitors or fluorescent lamp loads (AX) to EN 60 669.

The following functions can be set individually for each output:

- Time and ON/OFF delay functions
- Staircase lighting function with warning and modifiable staircase lighting time
- Recall of scenes/presets via 8/1 bit commands
- Logical functions AND, OR, XOR, GATE function
- Status messages
- Forced operation and safety functions
- Response to threshold values
- Control of electro-thermal valve drives
- Selection of the default state on bus voltage failure and recovery
- Output inversion

On Switch Actuators with current detection, SA/S x.16.6.1, each output also features the load current detection function with parameterizable response to two current threshold values. The current value can be sent via the bus. Individual outputs in the Switch Actuators can be copied or exchanged to minimize programming work.

The SA/S x.16.6.1 and SA/S x.16.5.1 are suitable for rated currents up to 20 A and have C-load switching capacity.

In the following table you will find an overview of the ABB i-bus<sup>®</sup> Switch Actuators and their type designations:

–	SA/S 2.6.2.1	SA/S 2.10.2.1	SA/S 2.16.2.1	SA/S 2.16.5.1	SA/S 2.16.6.1
SA/S 4.6.1.1	SA/S 4.6.2.1	SA/S 4.10.2.1	SA/S 4.16.2.1	SA/S 4.16.5.1	SA/S 4.16.6.1
SA/S 8.6.1.1	SA/S 8.6.2.1	SA/S 8.10.2.1	SA/S 8.16.2.1	SA/S 8.16.5.1	SA/S 8.16.6.1
SA/S 12.6.1.1	SA/S 12.6.2.1	SA/S 12.10.2.1	SA/S 12.16.2.1	SA/S 12.16.5.1	SA/S 12.16.6.1

#### Please note

The codes represent the following:

SA/S x.y.z.w

x = number of outputs (2, 4, 8 or 12)

y = rated current in Amperes (6, 10, 16)

z = load type specification:

1 = type with no manual operation

2 = type with manual operation

5 = type with higher switch capacity, C-load (200 µF)

6 = type with higher C-load switching capacity and current detection

w = version number

## 2 Device technology

### 2.1 Switch Actuators SA/S x.6.1.1, 6 A, MDRC



SA/S 12.6.1.1

2CDC 071 033 S0012

Switch Actuators SA/S x.6.1.1 6 A are modular installation devices in ProM design for installation in the distribution board. They are suitable for switching resistive, inductive and capacitive loads. The actuators can switch up to 12 independent electrical loads via floating contacts. The outputs are connected using screw terminals in groups of two contacts for SA/S 8.6.1.1 and SA/S 12.6.1.1. SA/S 4.6.1.1 has one terminal per output for power feed. Each output is controlled separately via KNX, regardless of the variant.

The device does not require an additional power supply and is ready for immediate use after the bus voltage has been applied. The Switch Actuator is parameterized via ETS. Connection to KNX is implemented using the bus connection terminal on the front.

#### 2.1.1 Technical data

<b>Supply</b>	KNX bus voltage	21...32 V DC		
	Current consumption, bus	< 12 mA		
	Power consumption	Maximum 250 mW		
<b>Rated output value</b>	SA/S type	4.6.1.1	8.6.1.1	12.6.1.1
	Current detection	no	no	no
	Number (floating contacts 2/group)	4 *)	8	12
	U <sub>n</sub> rated voltage	250/440 V AC (50/60 Hz)		
	I <sub>n</sub> rated current (per output)	6 A	6 A	6 A
	Leakage loss per device at max. load	1.5 W	2.0 W	2.5 W
<b>Output switching current</b>	AC3 <sup>1)</sup> operation (cos φ = 0.45) To EN 60 947-4-1	6 A/230 V AC		
	AC3 <sup>1)</sup> operation (cos φ = 0.8) To EN 60 947-4-1	6 A/230 V AC		
	Fluorescent lighting load to EN 60 669-1	6 A/250 V AC (35 μF) <sup>2)</sup>		
	Minimum switching capacity	20 mA/5 V AC		
		10 mA/12 V AC		
<b>Output service life</b>	Mechanical service life	> 10 <sup>7</sup>		
	Electrical endurance To IEC 60 947-4-1	AC1 <sup>1)</sup> (240 V/cos φ = 0.8)		
		> 10 <sup>5</sup>		
	AC3 <sup>1)</sup> (240 V/cos φ = 0.45)	> 1.5 x 10 <sup>4</sup>		
	AC5a <sup>1)</sup> (240 V/cos φ = 0.45)	> 1.5 x 10 <sup>4</sup>		

\*) Each output has one terminal for power feed.

# ABB i-bus<sup>®</sup> KNX

## Device technology

<b>Output switching times</b> <sup>3)</sup>	Maximum output relay position change per minute if all relays are switched simultaneously. The position changes should be distributed equally within the minute.	4.6.1.1 60	8.6.1.1 30	12.6.1.1 20
	Maximum output relay position change per minute if only one relay is switched.	240	240	240
<b>Connections</b>	KNX	Via bus connection terminals, 0.8 mm Ø, solid		
	Load circuits	Universal head screw terminal (PZ 1) 0.2... 4 mm <sup>2</sup> fine stranded, 2 x 0.2...2.5 mm <sup>2</sup> 0.2... 6 mm <sup>2</sup> solid, 2 x 0.2...4 mm <sup>2</sup>		
	Tightening torque	max. 0.6 Nm		
<b>Operating and display elements</b>	Programming button/LED	For assignment of physical address To EN 60		
<b>Degree of protection</b>	IP 20	529		
<b>Protection class</b>	II	To EN 61 140		
<b>Isolation category</b>	Overvoltage category	III to EN 60 664-1		
	Pollution degree	2 to EN 60 664-1		
<b>KNX safety extra low voltage</b>	SELV 24 V DC			
<b>Temperature range</b>	Operation	- 5 °C...+45 °C		
	Storage	-25 °C...+55 °C		
	Transport	-25 °C...+70 °C		
<b>Ambient conditions</b> □	Maximum air humidity	95 %, no condensation allowed		
<b>Design</b>	Modular installation device (MDRC)	Modular installation device, ProM		
	SA/S type	4.6.1.1	8.6.1.1	12.6.1.1
	Dimensions	90 x W x 64.5 mm (H x W x D)		
	Width W in mm	72	108	144
	Mounting width in units (18 mm modules)	4	6	8
	Mounting depth in mm	64.5	64.5	64.5
<b>Weight</b>	in kg	0.13	0.24	0.3
<b>Mounting</b>	On 35 mm mounting rail	To EN 60 715		
<b>Mounting position</b>	As required			
<b>Housing/color</b>	Plastic housing, gray			
<b>Approvals</b>	KNX to EN 50 090-1, -2	Certification		
<b>CE mark</b>	in accordance with the EMC guideline and low voltage guideline			

1) Further information concerning electrical endurance to IEC 60 947-4-1 can be found at: AC1, AC3, AX, C-load specifications, p. 43

2) The maximum inrush current peak may not be exceeded.

3) The specifications apply only after the bus voltage has been applied to the device for at least 30 seconds. Typical relay delay is approx. 20 ms.

### 2.1.2 Lamp output load at 230 V AC

<b>Lamps</b>	Incandescent lamp load	1,200 W
<b>Fluorescent lamps T5/T8</b>	Uncorrected	800 W
	Parallel compensated	300 W
	DUO circuit	350 W
<b>Low-voltage halogen lamps</b>	Inductive transformer	800 W
	Electronic transformer	1,000 W
	Halogen lamps 230 V	1,000 W
<b>Dulux lamp</b>	Uncorrected	800 W
	Parallel compensated	800 W
<b>Mercury-vapor lamp</b>	Uncorrected	1,000 W
	Parallel compensated	800 W
<b>Switching capacity (switching contact)</b>	Maximum peak inrush current $I_p$ (150 $\mu$ s)	200 A
	Maximum peak inrush current $I_p$ (250 $\mu$ s)	160 A
	Maximum peak inrush current $I_p$ (600 $\mu$ s)	100 A
<b>Number of electronic ballasts (T5/T8, single element)<sup>1)</sup></b>	18 W (ABB EVG 1 x 18 SF)	10
	24 W (ABB EVG-T5 1 x 24 CY)	10
	36 W (ABB EVG 1 x 36 CF)	7
	58 W (ABB EVG 1 x 58 CF)	5
	80 W (Helvar EL 1 x 80 SC)	3

<sup>1)</sup> For multiple element lamps or other types, the number of electronic ballasts must be determined using the peak inrush current of the electronic ballasts, see Ballast calculation, p. 42

Device type	Application program	Maximum number of communication objects	Maximum number of group addresses	Maximum number of associations
SA/S 4.6.1.1	Switch 4f 6A/...*	64	254	254
SA/S 8.6.1.1	Switch 8f 6A/...*	124	254	254
SA/S 12.6.1.1	Switch 12f 6A/...*	184	254	254

\* ... = current version number of the application program

#### Please note

ETS and the current version of the device application program are required for programming. The current application program is available for download at [www.abb.com/knx](http://www.abb.com/knx). After import into ETS it can be found under *ABB/Output/Binary output xf 6A/...\** (x = 4, 8 or 12). The device does not support the locking function of a KNX device in ETS. If you inhibit access to all of the project devices by using a *BCU code*, it has no effect on this device. Data can still be read and programmed.



## 2.1.4 Dimension drawing SA/S x.6.1.1

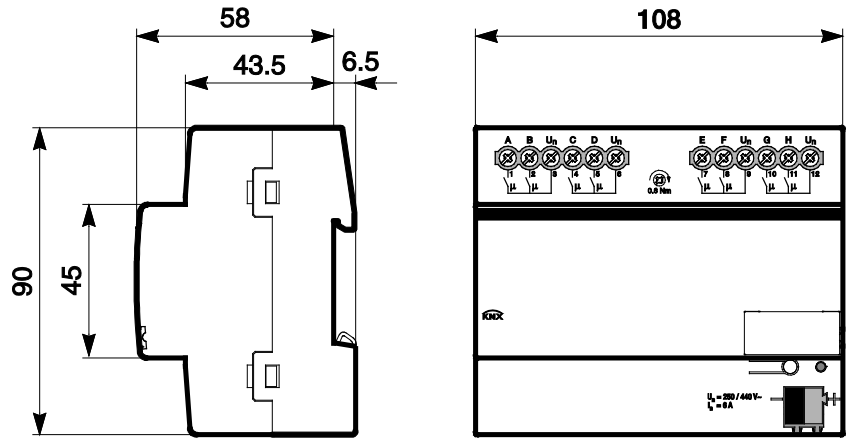

2CDC 072 077 F0011

	SA/S 4.6.1.1	SA/S 8.6.1.1	SA/S 12.6.1.1
Width W	72 mm	108 mm	144 mm
Mounting width (18 mm modules)	4 units	6 units	8 units

## 2.2 Switch Actuators SA/S x.6.2.1, 6 A, manual, MDRC



SA/S 8.6.2.1

Switch Actuators SA/S x.6.2.1, 6 A are modular installation devices in ProM design for installation in the distribution board. They are suitable for switching resistive, inductive and capacitive loads as well as fluorescent lamp loads (AX) to EN 60 669.

The Switch Actuator can be actuated manually using a button. This simultaneously indicates the contact position.

The actuators can switch up to 12 independent electrical loads via floating contacts. The connection of the outputs is implemented using combination screw terminals. Each output is controlled separately via KNX.

The device does not require an additional power supply and is ready for immediate use after the bus voltage has been applied.

The Switch Actuators are parameterized via ETS. Connection to KNX is implemented using the bus connection terminal on the front.

### 2.2.1 Technical data

<b>Supply</b>	KNX bus voltage	21...31 V DC			
	Current consumption via bus	< 12 mA			
	Power consumption via bus	Maximum 250 mW			
<b>Rated output value</b>	SA/S type	2.6.2.1	4.6.2.1	8.6.2.1	12.6.2.1
	Current detection	no	no	no	no
	Number (floating contacts)	2	4	8	12
	U <sub>n</sub> rated voltage	250/440 V AC (50/60 Hz)			
	I <sub>n</sub> rated current	6 AX	6 AX	6 AX	6 AX
	Leakage loss per device at max. load	0.9 W	1.2 W	1.5 W	3.9 W
<b>Output switching current</b>	AC3 <sup>1)</sup> operation (cos φ = 0.45) To EN 60 947-4-1	6 A/230 V AC			
	AC1 <sup>1)</sup> operation (cos φ = 0.8) To EN 60 947-4-1	6 A/230 V AC			
	Fluorescent lighting load to EN 60 669-1	6 AX/250 V AC (140 μF)2)			
	Minimum switching capacity	100 mA/12 V AC 100 mA/24 V AC			
	DC current switching capacity (resistive load)	6 A/24 V DC			
	<b>Output service life</b>	Mechanical service life	> 3 x 10 <sup>6</sup>		
Electrical endurance To IEC 60 947-4-1					
AC1 <sup>1)</sup> (240 V/cos φ = 0.8)		> 10 <sup>5</sup>			
AC3 <sup>1)</sup> (240 V/cos φ = 0.45)		> 3 x 10 <sup>4</sup>			
AC5a <sup>1)</sup> (240 V/cos φ = 0.45)		> 3 x 10 <sup>4</sup>			



# ABB i-bus<sup>®</sup> KNX

## Device technology

<b>Output switching times<sup>3)</sup></b>	SA/S type	2.6.2.1	4.6.2.1	8.6.2.1	12.6.2.1
	Maximum output relay position change per minute if all relays are switched simultaneously. The position changes should be distributed equally within the minute.	60	30	15	10
	Maximum output relay position change per minute if only one relay is switched.	120	120	120	120
<b>Connections</b>	KNX	Via bus connection terminals, 0.8 mm Ø, solid			
	Load circuits	Universal head screw terminal (PZ 1) 0.2... 4 mm <sup>2</sup> fine stranded, 2 x 0.2...2.5 mm <sup>2</sup> 0.2... 6 mm <sup>2</sup> solid, 2 x 0.2...4 mm <sup>2</sup>			
	Ferrules without/with plastic sleeves	0.25...2.5/4 mm <sup>2</sup>			
	TWIN ferrules	0.5...2.5 mm <sup>2</sup>			
	Tightening torque	Contact pin length min. 10 mm max. 0.6 Nm			
<b>Operating and display elements</b>	Programming button/LED	For assignment of the physical address			
	Contact position display	Relay operator			
<b>Degree of protection</b>	IP 20	To EN 60 529			
<b>Protection class</b>	II	To EN 61 140			
<b>Isolation category</b>	Overvoltage category	III to EN 60 664-1			
	Pollution degree	2 to EN 60 664-1			
<b>KNX safety extra low voltage</b>	SELV 24 V DC				
<b>Temperature range</b>	Operation	- 5 °C...+45 °C			
	Storage	-25 °C...+55 °C			
	Transport	-25 °C...+70 °C			
<b>Ambient conditions</b> □	Maximum air humidity	95 %, no condensation allowed			
<b>Design</b>	Modular installation device (MDRC)	Modular installation device, ProM			
	SA/S type	2.6.2.1	4.6.2.1	8.6.2.1	12.6.2.1
	Dimensions	90 x W x 64.5 mm (H x W x D)			
	Width W in mm	36	72	144	216
	Mounting width in units (18 mm modules)	2	4	8	12
	Mounting depth in mm	64.5	64.5	64.5	64.5
<b>Weight</b>	in kg	0.15	0.25	0.46	0.65
<b>Mounting</b>	On 35 mm mounting rail	To EN 60 715			
<b>Mounting position</b>	any				
<b>Housing/color</b>	Plastic housing, gray				
<b>Approvals</b>	KNX to EN 50 090-1, -2	Certification			
<b>CE mark</b>	in accordance with the EMC guideline and low voltage guideline				

<sup>1)</sup> Further information concerning electrical endurance to IEC 60 947-4-1 can be found at: AC1, AC3, AX, C-load specifications, p. 43

<sup>2)</sup> The maximum inrush current peak may not be exceeded.

<sup>3)</sup> The specifications apply only after the bus voltage has been applied to the device for at least 30 seconds. Typical relay delay is approx. 20 ms.

## 2.2.2 Lamp output load, 6 A

<b>Lamps</b>	Incandescent lamp load	1,380 W
<b>Fluorescent lamps T5/T8</b>	Uncorrected	1,380 W
	Parallel compensated	1,380 W
	DUO circuit	1,380 W
<b>Low-voltage halogen lamps</b>	Inductive transformer	1,200 W
	Electronic transformer	1,380 W
	Halogen lamps 230 V	1,380 W
<b>Dulux lamp</b>	Uncorrected	1,100 W
	Parallel compensated	1,100 W
<b>Mercury-vapor lamp</b>	Uncorrected	1,380 W
	Parallel compensated	1,380 W
<b>Switching capacity (switching contact)</b>	Maximum peak inrush current I <sub>p</sub> (150 μs)	400 A
	Maximum peak inrush current I <sub>p</sub> (250 μs)	320 A
	Maximum peak inrush current I <sub>p</sub> (600 μs)	200 A
<b>Number of electronic ballasts (T5/T8, single element)<sup>1)</sup></b>	18 W (ABB EVG 1 x 18 SF)	23
	24 W (ABB EVG-T5 1 x 24 CY)	23
	36 W (ABB EVG 1 x 36 CF)	14
	58 W (ABB EVG 1 x 58 CF)	11
	80 W (Helvar EL 1 x 80 SC)	10

<sup>1)</sup> For multiple element lamps or other types, the number of electronic ballasts must be determined using the peak inrush current of the electronic ballasts, see Ballast calculation, p. 42.

Device type	Application program	Maximum number of communication objects	Maximum number of group addresses	Maximum number of associations
SA/S 2.6.2.1	Switch 2f 6AM/...*	34	254	254
SA/S 4.6.2.1	Switch 4f 6AM/...*	64	254	254
SA/S 8.6.2.1	Switch 8f 6AM/...*	124	254	254
SA/S 12.6.2.1	Switch 12f 6AM/...*	184	254	254

\* ... = current version number of the application program

### Please note

ETS and the current version of the device application program are required for programming. The current application program is available for download at [www.abb.com/knx](http://www.abb.com/knx). After import into ETS it can be found under *ABB/Output/Binary output xf 6AM/...\** (x = 2, 4, 8 or 12).

The device does not support the locking function of a KNX device in ETS. If you inhibit access to all of the project devices by using a *BCU code*, it has no effect on this device.

Data can still be read and programmed.

## 2.2.3

Connection schematic SA/S x.6.2.1

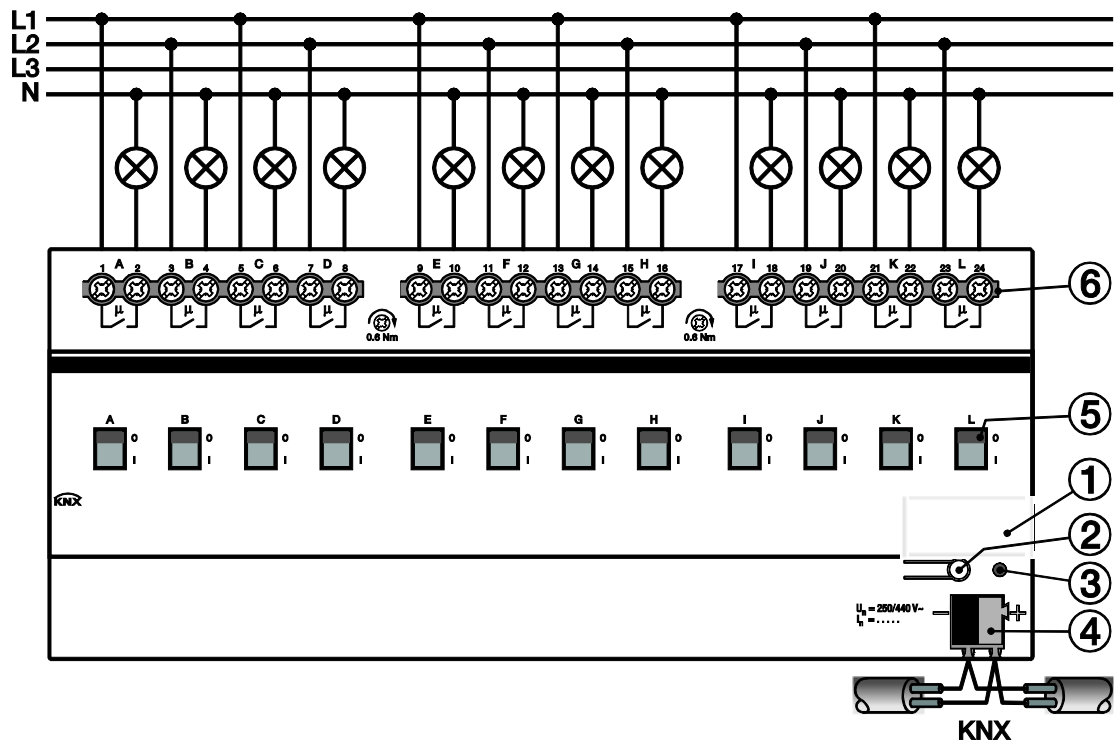

- 1 Label carrier
- 2 *Programming button*
- 3 *Programming LED*
- 4 Bus connection terminal
- 5 Contact position display and manual operation
- 6 Load current circuits, for every 2 connection terminals



**Danger**

Touch voltages.  
Danger of injury.  
Observe all-pole disconnection.

## 2.2.4 Dimension drawing SA/S x.6.2.1

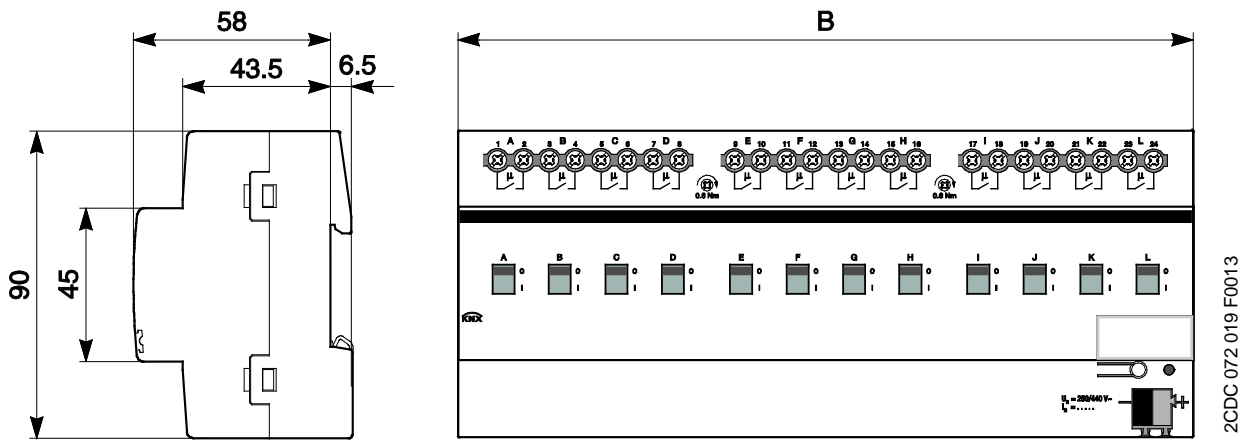

2CDC 072 019 F0013

	SA/S 2.6.2.1	SA/S 4.6.2.1	SA/S 8.6.2.1	SA/S 12.6.2.1
Width W	36 mm	72 mm	144 mm	216 mm
Mounting width (18 mm modules)	2 units	4 units	8 units	12 units

## 2.3 Switch Actuators SA/S x.10.2.1, 10 A, MDRC



SA/S 8.10.2.1

2CDC 071 016 S0012

Switch Actuators SA/S x.6.2.1, 10 A are modular installation devices in ProM design for installation in the distribution board. They are suitable for switching resistive, inductive and capacitive loads as well as fluorescent lamp loads (AX) to EN 60 669.

The Switch Actuator can be actuated manually using a button. This simultaneously indicates the contact position.

The Switch Actuators can switch up to 12 independent electrical loads via floating contacts. The connection of the outputs is implemented using combo-head screw terminals. Each output is controlled separately via KNX.

The device does not require an additional power supply and is ready for immediate use, after the bus voltage has been applied.

The Switch Actuators are parameterized via ETS. Connection to KNX is implemented using the bus connection terminal on the front.

### 2.3.1 Technical data

<b>Supply</b>	KNX bus voltage	21...31 V			
	Current consumption via bus	< 12 mA			
	Power consumption via bus	Maximum 250 mW			
<b>Rated output value</b>	SA/S type	2.10.2.1	4.10.2.1	8.10.2.1	12.10.2.1
	Current detection	no	no	no	no
	Number (floating contacts 2/group)	2	4	8	12
	U <sub>n</sub> rated voltage	250/440 V AC (50/60 Hz)			
	I <sub>n</sub> rated current	10 AX	10 AX	10 AX	10 AX
	Leakage loss per device at max. load	1.5 W	2.0 W	2.5 W	6.5 W
<b>Output switching current</b>	AC3 <sup>1)</sup> operation (cos φ = 0.45) To EN 60 947-4-1	8 A / 230 V AC			
	AC1 <sup>1)</sup> operation (cos φ = 0.8) To EN 60 947-4-1	10 A / 230 V AC			
	Fluorescent lighting load to EN 60 669-1	10 AX/250 V AC (140 μF) <sup>2)</sup>			
	Minimum switching capacity	100 mA/12 V AC 100 mA/24 V AC			
	DC current switching capacity (resistive load)	10 A/24 V DC			
<b>Output service life</b>	Mechanical service life	> 3 x 10 <sup>6</sup>			
	Electrical endurance To IEC 60 947-4-1				
	AC1 <sup>1)</sup> (240 V/cos φ = 0.8)	> 10 <sup>5</sup>			
	AC3 <sup>1)</sup> (240 V/cos φ = 0.45)	> 3 x 10 <sup>4</sup>			
	AC5a <sup>1)</sup> (240 V/cos φ = 0.45)	> 3 x 10 <sup>4</sup>			

# ABB i-bus<sup>®</sup> KNX

## Device technology

<b>Output switching times<sup>3)</sup></b>	Maximum relay position change of output and minute if all relays are switched simultaneously. The position changes should be distributed equally within the minute.	2.10.2.1 60	4.10.2.1 30	8.10.2.1 15	12.10.2.1 10
	Maximum output relay position change per minute if only one relay is switched.	120	120	120	120
<b>Connections</b>	KNX	Via bus connection terminals, 0.8 mm Ø, solid			
	Load current circuits (1 terminal per contact)	Universal head screw terminal (PZ 1) 0.2... 4 mm <sup>2</sup> fine stranded, 2 x 0.2...2.5 mm <sup>2</sup> 0.2... 6 mm <sup>2</sup> solid, 2 x 0.2...4 mm <sup>2</sup>			
	Ferrules without/with plastic sleeves	0.25...2.5/4 mm <sup>2</sup>			
	TWIN ferrules	0.5...2.5 mm <sup>2</sup>			
	Tightening torque	Contact pin length min. 10 mm max. 0.6 Nm			
<b>Operating and display elements</b>	Programming button/LED	For assignment of the physical address			
	Contact position display	Relay operator			
<b>Degree of protection</b>	IP 20	To EN 60 529			
<b>Protection class</b>	II	To EN 61 140			
<b>Isolation category</b>	Overvoltage category	III to EN 60 664-1			
	Pollution degree	2 to EN 60 664-1			
<b>KNX safety extra low voltage</b>	SELV 24 V DC				
<b>Temperature range</b>	Operation	- 5 °C...+45 °C			
	Storage	-25 °C...+55 °C			
	Transport	-25 °C...+70 °C			
<b>Ambient conditions</b>	Maximum air humidity	95 %, no condensation allowed			
<b>Design</b>	Modular installation device (MDRC)	Modular installation device, ProM			
	SA/S type	2.10.2.1	4.10.2.1	8.10.2.1	12.10.2.1
	Dimensions	90 x W x 64.5 mm (H x W x D)			
	Width W in mm	36	72	144	216
	Mounting width in units (18 mm modules)	2	4	8	12
	Mounting depth in mm	64.5	64.5	64.5	64.5
<b>Weight</b>	in kg	0.15	0.25	0.46	0.65
<b>Mounting</b>	On 35 mm mounting rail	To EN 60 715			
<b>Mounting position</b>	As required				
<b>Housing/color</b>	Plastic housing, gray				
<b>Approvals</b>	KNX to EN 50 090-1, -2	Certification			
<b>CE mark</b>	in accordance with the EMC guideline and low voltage guideline				

<sup>1)</sup> Further information concerning electrical endurance to IEC 60 947-4-1 can be found at: [AC1, AC3, AX, C-load specifications](#), p. 43

<sup>2)</sup> The maximum inrush current peak may not be exceeded.

<sup>3)</sup> The specifications apply only after the bus voltage has been applied to the device for at least 30 seconds. Typical relay delay is approx. 20 ms.

## 2.3.2 Lamp output load 10 A

<b>Lamps</b>	Incandescent lamp load	2,500 W
<b>Fluorescent lamps T5/T8</b>	Uncorrected	2,500 W
	Parallel compensated	1,500 W
	DUO circuit	1,500 W
<b>Low-voltage halogen lamps</b>	Inductive transformer	1,200 W
	Electronic transformer	1,500 W
	Halogen lamps 230 V	2,500 W
<b>Dulux lamp</b>	Uncorrected	1,100 W
	Parallel compensated	1,100 W
<b>Mercury-vapor lamp</b>	Uncorrected	2,000 W
	Parallel compensated	2,000 W
<b>Switching capacity (switching contact)</b>	Maximum peak inrush current $I_p$ (150 $\mu$ s)	400 A
	Maximum peak inrush current $I_p$ (250 $\mu$ s)	320 A
	Maximum peak inrush current $I_p$ (600 $\mu$ s)	200 A
<b>Number of electronic ballasts (T5/T8, single element)<sup>1)</sup></b>	18 W (ABB EVG 1 x 18 SF)	23
	24 W (ABB EVG-T5 1 x 24 CY)	23
	36 W (ABB EVG 1 x 36 CF)	14
	58 W (ABB EVG 1 x 58 CF)	11
	80 W (Helvar EL 1 x 80 SC)	10

<sup>1)</sup> For multiple element lamps or other types, the number of electronic ballasts must be determined using the peak inrush current of the electronic ballasts, see [Ballast calculation](#), p. 42.

Device type	Application program	Maximum number of communication objects	Maximum number of group addresses	Maximum number of associations
SA/S 2.10.2.1	Switch 2f 10A/...*	34	254	254
SA/S 4.10.2.1	Switch 4f 10A/...*	64	254	254
SA/S 8.10.2.1	Switch 8f 10A/...*	124	254	254
SA/S 12.10.2.1	Switch 12f 10A/...*	184	254	254

\* ... = current version number of the application program

### Please note

ETS and the current version of the device application program are required for programming.

The current application program is available for download at [www.abb.com/knx](http://www.abb.com/knx). After import into ETS, it is available in ETS under *ABB/Output/Binary output xf 10A/...\** (x = 2, 4, 8 or 12).

The device does not support the locking function of a KNX device in ETS. If you inhibit access to all of the project devices by using a *BCU code*, it has no effect on this device.

Data can still be read and programmed.

## 2.3.3

### Connection schematic SA/S x.10.2.1

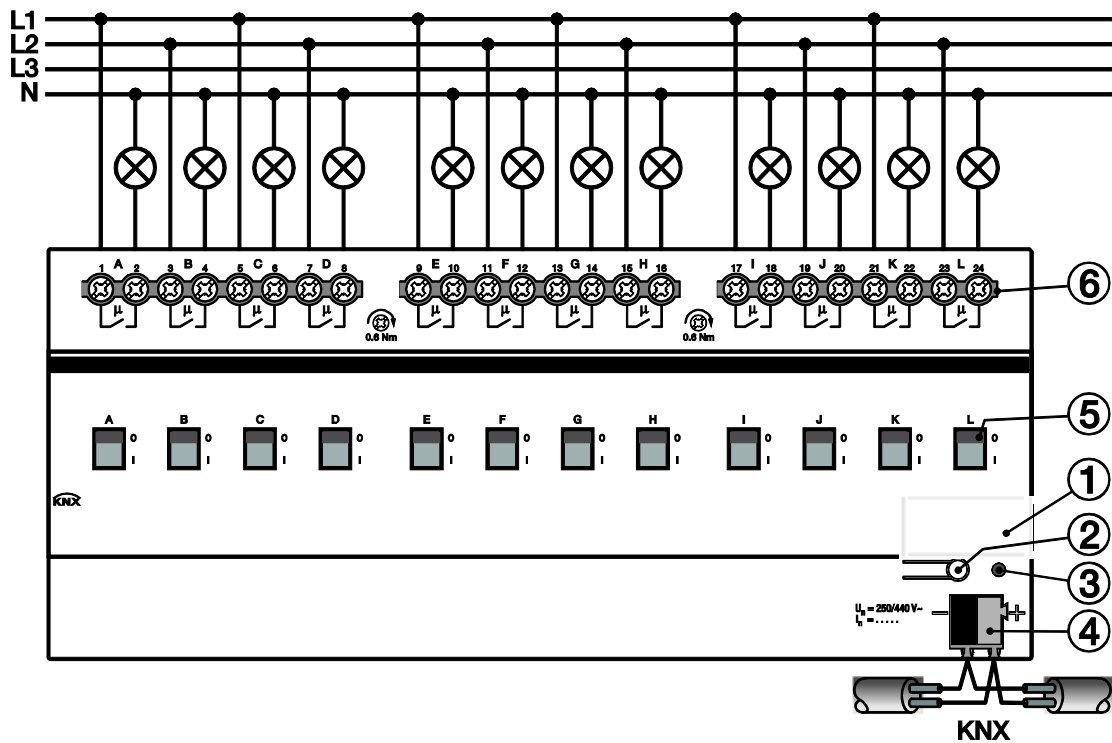

- 1 Label carrier
- 2 *Programming button*
- 3 *Programming LED*
- 4 Bus connection terminal
- 5 Contact position display and manual operation
- 6 Load current circuits, for every 2 connection terminals



**Danger**

Touch voltages.  
Danger of injury.  
Observe all-pole disconnection.



# ABB i-bus<sup>®</sup> KNX Device technology

## 2.3.4 Dimension drawing SA/S x.10.2.1

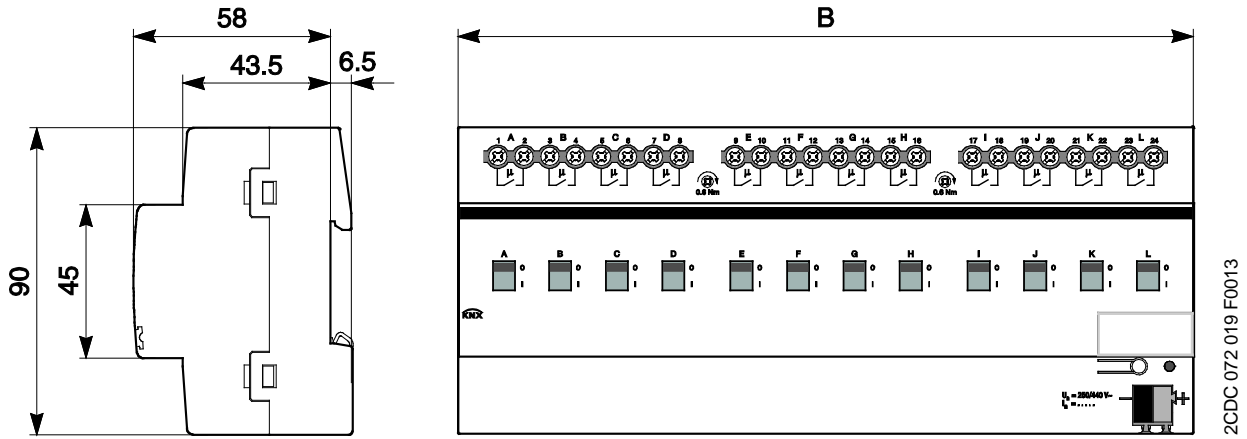

	SA/S 2.10.2.1	SA/S 4.10.2.1	SA/S 8.10.2.1	SA/S 12.10.2.1
Width W	36 mm	72 mm	144 mm	216 mm
Mounting width (18 mm modules)	2 units	4 units	8 units	12 units

## 2.4 Switch Actuators SA/S x.16.2.1, 16 A MDRC



2CDC 071 017 S0012

Switch Actuators SA/S x.16.2.1, 16 A are modular installation devices in ProM design for installation in the distribution board. They are especially suitable for switching resistive loads.

The Switch Actuator can be actuated manually using a button. This simultaneously indicates the contact position.

The Switch Actuators can switch up to 12 independent electrical loads via floating contacts. The connection of the outputs is implemented using comb-head screw terminals. Each output is controlled separately via KNX.

The device does not require an additional power supply and is ready for immediate use, after the bus voltage has been applied.

The Switch Actuators are parameterized via ETS. Connection to KNX is implemented using the bus connection terminal on the front.

SA/S 8.16.2.1

### 2.4.1 Technical data

<b>Supply</b>	KNX bus voltage	21...31 V DC				
	Current consumption via bus	< 12 mA				
	Power consumption via bus	Maximum 250 mW				
<b>Rated output value</b>	SA/S type	2.16.2.1	4.16.2.1	8.16.2.1	12.16.2.1	
	Current detection	no	no	no	no	
	Number (floating contacts 2/group)	2	4	8	12	
	U <sub>n</sub> rated voltage	250/440 V AC (50/60 Hz)				
	I <sub>n</sub> rated current	16 A	16 A	16 A	16 A	
	Leakage loss per device at max. load	2.0 W	4.0 W	8.0 W	12.0 W	
<b>Output switching current</b>	AC3 <sup>1)</sup> operation (cos φ = 0.45) To EN 60 947-4-1	8 A / 230 V AC				
	AC1 <sup>1)</sup> operation (cos φ = 0.8) To EN 60 947-4-1	16 A/230 V AC				
	Fluorescent lighting load to EN 60 669-1	16 AX/250 V AC (70 μF) <sup>2)</sup>				
	Minimum switching capacity	100 mA/12 V AC 100 mA/24 V AC				
	DC current switching capacity (resistive load)	16 A/24 V DC				
	<b>Output service life</b>	Mechanical service life	> 3 x 10 <sup>6</sup>			
		Electrical endurance To IEC 60 947-4-1				
AC1 <sup>1)</sup> (240 V/cos φ = 0.8)		> 10 <sup>5</sup>				
AC3 <sup>1)</sup> (240 V/cos φ = 0.45)		> 3 x 10 <sup>4</sup>				
AC5a <sup>1)</sup> (240 V/cos φ = 0.45)		> 3 x 10 <sup>4</sup>				

# ABB i-bus<sup>®</sup> KNX

## Device technology

<b>Output switching times<sup>3)</sup></b>	Maximum relay position change of output and minute if all relays are switched simultaneously. The position changes should be distributed equally within the minute.	2.10.2.1 60	4.10.2.1 30	8.10.2.1 15	12.10.2.1 10
	Maximum output relay position change per minute if only one relay is switched.	120	120	120	120
<b>Connections</b>	KNX	Via bus connection terminals, 0.8 mm Ø, solid			
	Load current circuits (1 terminal per contact)	Universal head screw terminal (PZ 1) 0.2... 4 mm <sup>2</sup> fine stranded, 2 x 0.2...2.5 mm <sup>2</sup> 0.2... 6 mm <sup>2</sup> solid, 2 x 0.2...4 mm <sup>2</sup>			
	Ferrules without/with plastic sleeves	0.25...2.5/4 mm <sup>2</sup>			
	TWIN ferrules	0.5...2.5 mm <sup>2</sup>			
	Tightening torque	Contact pin length min. 10 mm max. 0.6 Nm			
<b>Operating and display elements</b>	Programming button/LED	For assignment of the physical address			
	Contact position display	Relay operator			
<b>Degree of protection</b>	IP 20	To EN 60 529			
<b>Protection class</b>	II	To EN 61 140			
<b>Isolation category</b>	Overvoltage category	III to EN 60 664-1			
	Pollution degree	2 to EN 60 664-1			
<b>KNX safety extra low voltage</b>	SELV 24 V DC				
<b>Temperature range</b>	Operation	- 5 °C...+45 °C			
	Storage	-25 °C...+55 °C			
	Transport	-25 °C...+70 °C			
<b>Ambient conditions</b>	Maximum air humidity	95 %, no condensation allowed			
<b>Design</b>	Modular installation device (MDRC)	Modular installation device, ProM			
	SA/S type	2.10.2.1	4.10.2.1	8.10.2.1	12.10.2.1
	Dimensions	90 x W x 64.5 mm (H x W x D)			
	Width W in mm	36	72	144	216
	Mounting width in units (18 mm modules)	2	4	8	12
	Mounting depth in mm	64.5	64.5	64.5	64.5
<b>Weight</b>	in kg	0.15	0.25	0.46	0.65
<b>Mounting</b>	On 35 mm mounting rail	To EN 60 715			
<b>Mounting position</b>	any				
<b>Housing/color</b>	Plastic housing, gray				
<b>Approvals</b>	KNX to EN 50 090-1, -2	Certification			
<b>CE mark</b>	in accordance with the EMC guideline and low voltage guideline				

<sup>1)</sup> Further information concerning electrical endurance to IEC 60 947-4-1 can be found at: [AC1, AC3, AX, C-load specifications](#), p. 43

<sup>2)</sup> The maximum inrush current peak may not be exceeded.

<sup>3)</sup> The specifications apply only after the bus voltage has been applied to the device for at least 30 seconds. Typical relay delay is approx. 20 ms.

## 2.4.2 Lamp output load 16 A

<b>Lamps</b>	Incandescent lamp load	2,500 W
<b>Fluorescent lamps T5/T8</b>	Uncorrected	2,500 W
	Parallel compensated	1,500 W
	DUO circuit	1,500 W
<b>Low-voltage halogen lamps</b>	Inductive transformer	1,200 W
	Electronic transformer	1,500 W
	Halogen lamps 230 V	2,500 W
<b>Dulux lamp</b>	Uncorrected	1,100 W
	Parallel compensated	1,100 W
<b>Mercury-vapor lamp</b>	Uncorrected	2,000 W
	Parallel compensated	2,000 W
<b>Switching capacity (switching contact)</b>	Maximum peak inrush current $I_p$ (150 $\mu$ s)	400 A
	Maximum peak inrush current $I_p$ (250 $\mu$ s)	320 A
	Maximum peak inrush current $I_p$ (600 $\mu$ s)	200 A
<b>Number of electronic ballasts (T5/T8, single element)<sup>1)</sup></b>	18 W (ABB EVG 1 x 18 SF)	23
	24 W (ABB EVG-T5 1 x 24 CY)	23
	36 W (ABB EVG 1 x 36 CF)	14
	58 W (ABB EVG 1 x 58 CF)	11
	80 W (Helvar EL 1 x 80 SC)	10

<sup>1)</sup> For multiple element lamps or other types, the number of electronic ballasts must be determined using the peak inrush current of the electronic ballasts, see [Ballast calculation](#), p. 42

Device type	Application program	Maximum number of communication objects	Maximum number of group addresses	Maximum number of associations
SA/S 2.10.2.1	Switch 2f 10A/...*	34	254	254
SA/S 4.10.2.1	Switch 4f 10A/...*	64	254	254
SA/S 8.10.2.1	Switch 8f 10A/...*	124	254	254
SA/S 12.10.2.1	Switch 12f 10A/...*	184	254	254

\* ... = current version number of the application program

### Please note

ETS and the current version of the device application program are required for programming. The current application program is available for download at [www.abb.com/knx](http://www.abb.com/knx). After import into ETS, it is available in ETS under *ABB/Output/Binary output xf 10A/...\** (x = 2, 4, 8 or 12). The device does not support the locking function of a KNX device in ETS. If you inhibit access to all devices of the project with a *BCU code*, it has no effect on this device. Data can still be read and programmed.

## 2.4.3

Connection schematic SA/S x.16.2.1

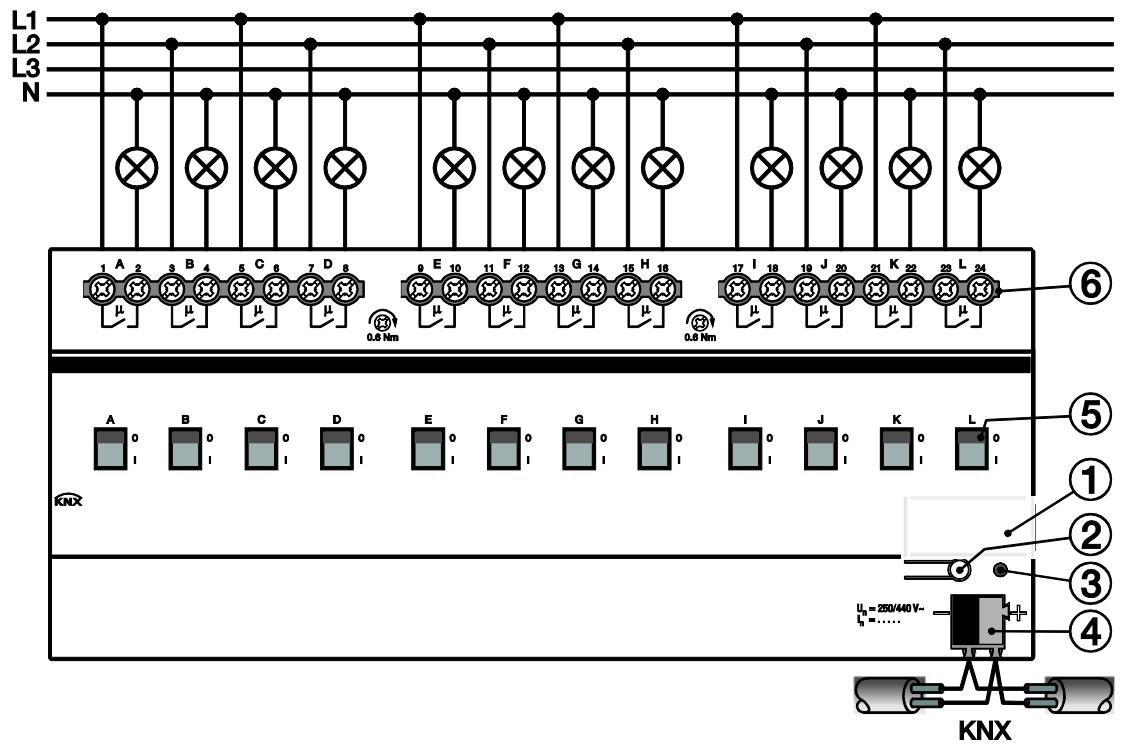

- 1 Label carrier
- 2 *Programming* button
- 3 *Programming* LED
- 4 Bus connection terminal
- 5 Contact position display and manual operation
- 6 Load current circuits, for every 2 connection terminals



**Danger**

Touch voltages.  
Danger of injury.  
Observe all-pole disconnection.

## 2.4.4 Dimension drawing SA/S x.16.2.1

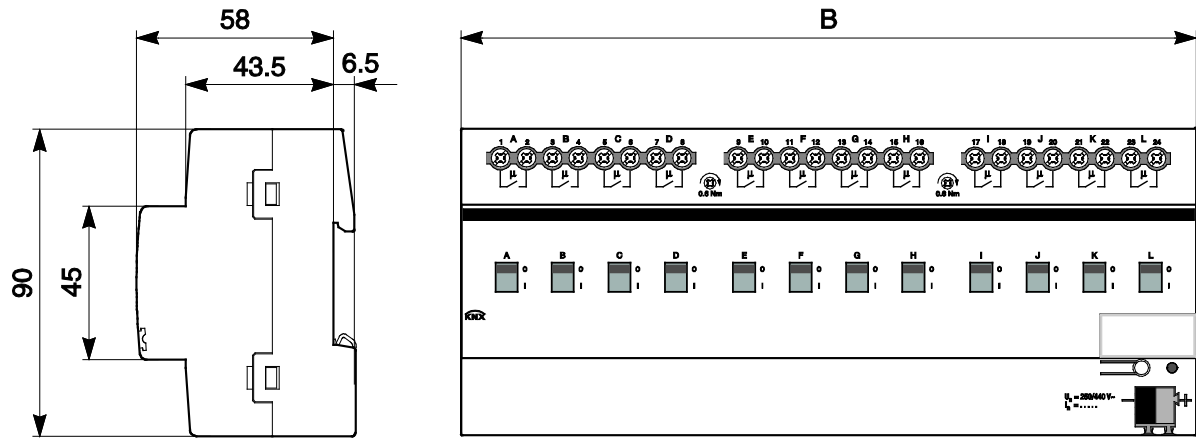

2CDC 072 019 F0013

	SA/S 2.16.2.1	SA/S 4.16.2.1	SA/S 8.16.2.1	SA/S 12.16.2.1
Width W	36 mm	72 mm	144 mm	216 mm
Mounting width (18 mm modules)	2 units	4 units	8 units	12 units

## 2.5 Switch Actuator SA/S 16.5.1, 16/20 A, MDRC



SA/S 12.16.5.1

2CDC 071 001 S0011

Switch Actuators SA/S x.16.5.1, 16/20 A are modular installation devices in ProM design for installation in the distribution board. They are especially suitable for switching loads with high peak inrush currents such as lighting equipment with compensation capacitors or fluorescent lamp loads (AX) to EN 60 669.

Manual actuation of the Switch Actuator is possible using a button. This simultaneously indicates the contact position.

The Switch Actuators can switch up to 12 independent electrical loads via floating contacts. The maximum load current per output is 20 A. The connection of the outputs is implemented using combo-head screw terminals. Each output is controlled separately via KNX.

The devices do not require an additional power supply and are ready for immediate use, after the bus voltage has been applied.

The Switch Actuators are parameterized via ETS. Connection to KNX is implemented using the bus connection terminal on the front.

### 2.5.1 Technical data

<b>Supply</b>	KNX bus voltage	21...31 V DC			
	Current consumption via bus	< 12 mA			
	Power consumption via bus	Maximum 250 mW			
<b>Rated output value</b>	SA/S type	2.16.5.1	4.16.5.1	8.16.5.1	12.16.5.1
	Current detection	no	no	no	no
	Number (floating contacts)	2	4	8	12
	U <sub>n</sub> rated voltage	250/440 V AC (50/60 Hz)			
	I <sub>n</sub> rated current	16/20 AX, C-load			
	Leakage loss per device at max. load 16 A	2.0 W 4.0 W 8.0 W 12 W			
	Leakage loss per device at max. load 20 A	3.0 W	5.5 W	11.0 W	16 W
<b>Output switching current</b>	AC3 <sup>1)</sup> operation (cos φ = 0.45) To EN 60 947-4-1	16 A/230 V AC			
	AC1 <sup>1)</sup> operation (cos φ = 0.8) To EN 60 947-4-1	16/20 A/230 V AC			
	Fluorescent lighting load to EN 60 669-1	16/20 AX/250 V AC (200 μF) <sup>2)</sup>			
	Minimum switching capacity	100 mA/12 V AC			
		100 mA/24 V AC			
<b>Output service life</b>	DC current switching capacity (resistive load)	20 A/24 V DC			
	Mechanical service life	> 10 <sup>6</sup>			
	Electrical endurance to IEC 60 947-4-1				
	AC1 <sup>1)</sup> (240 V/cos φ = 0.8)	> 10 <sup>5</sup>			
	AC3 <sup>1)</sup> (240 V/cos φ = 0.45)	> 3 x 10 <sup>4</sup>			
AC5a <sup>1)</sup> (240 V/cos φ = 0.45)	> 3 x 10 <sup>4</sup>				

# ABB i-bus<sup>®</sup> KNX

## Device technology

<b>Output switching times<sup>3)</sup></b>	Maximum relay position changes per output per minute if all relays are switched simultaneously. Position changes should be distributed equally within the minute.	2.16.5.1 30	4.16.5.1 15	8.16.5.1 7	12.16.5.1 5
	Maximum relay position changes per output per minute if only one relay is switched.	60	60	60	60
<b>Connections</b>	KNX	Via bus connection terminals, 0.8 mm Ø, solid			
	Load circuits	Universal head screw terminal (PZ 1) 0.2... 4 mm <sup>2</sup> fine stranded, 2 x 0.2...2.5 mm <sup>2</sup> 0.2... 6 mm <sup>2</sup> solid, 2 x 0.2...4 mm <sup>2</sup>			
	Ferrules without/with plastic sleeves	0.25...2.5/4 mm <sup>2</sup>			
	TWIN ferrules	0.5...2.5 mm <sup>2</sup>			
	Tightening torque	Contact pin length min. 10 mm max. 0.6 Nm			
<b>Operating and display elements</b>	Programming button/LED	For assignment of the physical address			
	Contact position display	Relay operator			
<b>Degree of protection</b>	IP 20	To EN 60 529			
<b>Protection class</b>	II	To EN 61 140			
<b>Isolation category</b>	Overvoltage category	III to EN 60 664-1			
	Pollution degree	2 to EN 60 664-1			
<b>KNX safety extra low voltage</b>	SELV 24 V DC				
<b>Temperature range</b>	Operation	- 5 °C...+45 °C			
	Storage	-25...+55 °C			
	Transport	-25...+70 °C			
<b>Ambient conditions</b>	Maximum air humidity	95 %, no condensation allowed			
<b>Design</b>	Modular installation device (MDRC)	2.16.5.1	4.16.5.1	8.16.5.1	12.16.5.1
	Dimensions	90 x W x 64.5 mm (H x W x D)			
	Width W in mm	36	72	144	216
	Mounting width in units (18 mm modules)	2	4	8	12
	Mounting depth in mm	64.5	64.5	64.5	64.5
<b>Weight</b>	in kg	0.2	0.34	0.64	0.75
<b>Mounting</b>	On 35 mm mounting rail	To EN 60 715			
<b>Mounting position</b>	any				
<b>Housing/color</b>	Plastic housing, gray				
<b>Approvals</b>	KNX to EN 50 090-1, -2	Certification			
<b>CE mark</b>	in accordance with the EMC guideline and low voltage guideline				

<sup>1)</sup> Further information concerning electrical endurance to IEC 60 947-4-1 can be found at: [AC1, AC3, AX, C-load specifications](#), p. 43

<sup>2)</sup> The maximum inrush current peak may not be exceeded.

<sup>3)</sup> The specifications apply only after the bus voltage has been applied to the device for at least 30 seconds. Typical relay delay is approx. 20 ms.



### 2.5.2 Lamp output load 16/20 A

<b>Lamps</b>	Incandescent lamp load	3,680 W
<b>Fluorescent lamps T5/T8</b>	Uncorrected	3,680 W
	Parallel compensated	2,500 W
	DUO circuit	3,680 W
<b>Low-voltage halogen lamps</b>	Inductive transformer	2,000 W
	Electronic transformer	2,500 W
	Halogen lamps 230 V	3,680 W
<b>Dulux lamp</b>	Uncorrected	3,680 W
	Parallel compensated	3,000 W
<b>Mercury-vapor lamp</b>	Uncorrected	3,680 W
	Parallel compensated	3,680 W
<b>Switching capacity (switching contact)</b>	Maximum peak inrush current $I_p$ (150 $\mu$ s)	600 A
	Maximum peak inrush current $I_p$ (250 $\mu$ s)	480 A
	Maximum peak inrush current $I_p$ (600 $\mu$ s)	300 A
<b>Number of electronic ballasts (T5/T8, single element)<sup>1)</sup></b>	18 W (ABB EVG 1 x 18 SF)	26 <sup>2)</sup>
	24 W (ABB EVG-T5 1 x 24 CY)	26 <sup>2)</sup>
	36 W (ABB EVG 1 x 36 CF)	22
	58 W (ABB EVG 1 x 58 CF)	12 <sup>2)</sup>
	80 W (Helvar EL 1 x 80 SC)	10 <sup>2)</sup>

<sup>1)</sup> For multiple element lamps or other types, the number of electronic ballasts must be determined using the peak inrush current of the electronic ballasts, see [Ballast calculation](#), p. 42.

<sup>2)</sup> The number of ballasts is limited by protection with B16 circuit-breakers.

Device type	Application program	Maximum number of communication objects	Maximum number of group addresses	Maximum number of associations
SA/S 2.16.5.1	Switch 2f 16C/...*	34	254	254
SA/S 4.16.5.1	Switch 4f 16C/...*	64	254	254
SA/S 8.16.5.1	Switch 8f 16C/...*	124	254	254
SA/S 12.16.5.1	Switch 12f 16C/...*	184	254	254

\* ... = current version number of the application program

#### Please note

ETS and the current version of the device application program are required for programming.

The current application program is available for download at [www.abb.com/knx](http://www.abb.com/knx). After import into ETS, it is available in ETS under *ABB/Output/Binary output xf 16C/...\** ( $x = 2, 4, 8$  or  $12$ ).

The device does not support the locking function of a KNX device in ETS. If you inhibit access to all of the project devices by using a *BCU code*, it has no effect on this device.

Data can still be read and programmed.

2.5.3

Connection schematic SA/S 12.16.5.1

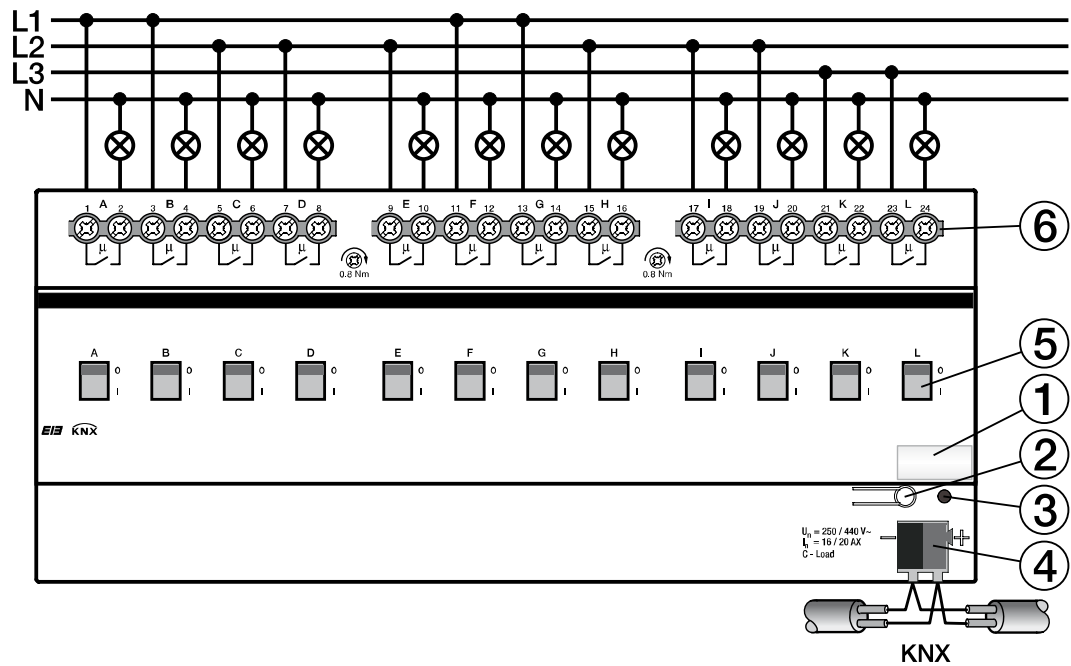

- 1 Label carrier
- 2 *Programming* button
- 3 *Programming* LED
- 4 Bus connection terminal
- 5 Contact position display and manual operation
- 6 Load current circuits, for every 2 connection terminals



**Danger**

Touch voltages.  
Danger of injury.  
Observe all-pole disconnection.

2CDC 072 177 F0009

# ABB i-bus<sup>®</sup> KNX Device technology

## 2.5.4 Dimension drawing SA/S 12.16.5.1

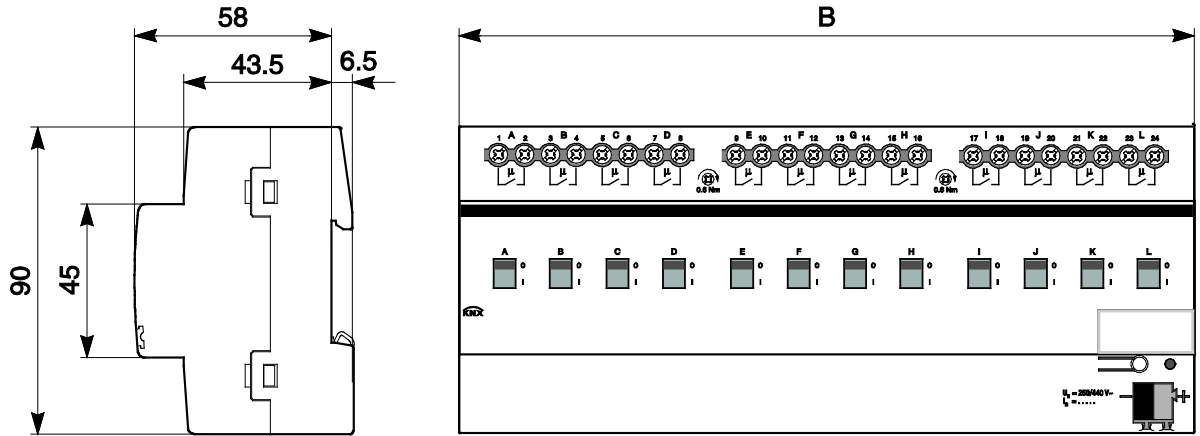

2CDC 072.019 F0013

	SA/S 2.16.5.1	SA/S 4.16.5.1	SA/S 8.16.5.1	SA/S 12.16.5.1
Width W	36 mm	72 mm	144 mm	216 mm
Mounting width (18 mm modules)	2 units	4 units	8 units	12 units

## 2.6 Switch Actuators SA/S x.16.6.1, 16/20 A, MDRC



SA/S 8.16.6.1

2CDC 071 006 S0010

Switch Actuators SA/S x.16.6.1, 16/20 A are modular installation devices in ProM design for installation in the distribution board. They are especially suitable for switching loads with high peak inrush currents such as lighting equipment with compensation capacitors or fluorescent lamp loads (AX) to EN 60 669.

The Switch Actuators feature one load current detection per output.

The maximum load current per output is 20 A.

The Switch Actuator can be actuated manually using a button. This simultaneously indicates the contact position.

The Switch Actuators can switch up to 12 independent electrical loads via floating contacts. The maximum load current per output is 20 A. The connection of the outputs is implemented using combo-head screw terminals. Each output is controlled separately via KNX.

Individual outputs on SA/S x.16.6.1 devices can be copied or exchanged to minimize programming work.

The device does not require an additional power supply and is ready for immediate use, after the bus voltage has been applied.

The Switch Actuators are parameterized via ETS. Connection to KNX is implemented using the bus connection terminal on the front.

### 2.6.1 Technical data

<b>Supply</b>	KNX bus voltage	21...31 V DC				
	Current consumption via bus	< 12 mA				
	Power consumption via bus	Maximum 250 mW				
<b>Rated output value</b>	SA/S type	2.16.6.1	4.16.6.1	8.16.6.1	12.16.6.1	
	Current detection	yes	yes	yes	yes	
	Number (floating contacts 2/group)	2	4	8	12	
	U <sub>n</sub> rated voltage	250/440 V AC (50/60 Hz)				
	I <sub>n</sub> rated current	16/20 AX, C-load				
	Leakage loss per device at max. load 16 A	2.0 W	4.0 W	8.0 W	12.0 W	
	Leakage loss per device at max. load 20 A	3.0 W	5.5 W	11.0 W	16.0 W	
<b>Output switching current</b>	AC3 <sup>1)</sup> operation (cos φ = 0.45) To EN 60 947-4-1	16 A/230 V AC				
	AC1 <sup>1)</sup> operation (cos φ = 0.8) To EN 60 947-4-1	16/20 A/230 V AC				
	Fluorescent lighting load to EN 60 669-1	16/20 AX/250 V AC (200 μF) <sup>2)</sup>				
	Minimum switching capacity	100 mA/12 V AC				
		100 mA/24 V AC				
		DC current switching capacity (resistive load)	20 A/24 V DC			

# ABB i-bus<sup>®</sup> KNX

## Device technology

<b>Output service life</b>	Mechanical service life	> 10 <sup>6</sup>			
	Electrical endurance				
	To IEC 60 947-4-1				
	AC1 <sup>1)</sup> (240 V/cos φ = 0.8)	> 10 <sup>5</sup>			
	AC3 <sup>1)</sup> (240 V/cos φ = 0.45)	> 3 x 10 <sup>4</sup>			
	AC5a <sup>1)</sup> (240 V/cos φ = 0.45)	> 3 x 10 <sup>4</sup>			
<b>Current detection (load current)</b>	Detection range (sine effective value)	0.02...20 A			
	Accuracy	+/- 2 % of actual current value (sine) and +/- 20 mA			
	Frequency	50/60 Hz			
	2 byte representation (figure value, DTP 7.012) or 4 byte representation (floating value, DTP 14.019)	in mA			
	Measurement speed:				
	– Low-pass filter transient response with τ	300 ms			
	– Scanning frequency of the current value	320 ms			
<b>Output switching times<sup>3)</sup></b>	Maximum relay position changes per output per minute if all relays are switched simultaneously. The position changes should be distributed equally within the minute.	2.16.6.1	4.16.6.1	8.16.6.1	12.16.6.1
		30	15	7	5
	Maximum relay position changes per output per minute if only one relay is switched.	60	60	60	60
<b>Connections</b>	KNX	Via bus connection terminals, 0.8 mm Ø, solid			
	Load circuits	Universal head screw terminal (PZ 1) 0.2... 4 mm <sup>2</sup> fine stranded, 2 x 0.2...2.5 mm <sup>2</sup> 0.2... 6 mm <sup>2</sup> solid, 2 x 0.2...4 mm <sup>2</sup>			
	Ferrules without/with plastic sleeves	0.25...2.5/4 mm <sup>2</sup>			
	TWIN ferrules	0.5...2.5 mm <sup>2</sup>			
		Contact pin length min. 10 mm			
<b>Operating and display elements</b>	Programming button/LED	For assignment of the physical address			
	Contact position display	Relay operator			
<b>Degree of protection</b>	IP 20	To EN 60 529			
<b>Protection class</b>	II	To EN 61 140			
<b>Isolation category</b>	Overvoltage category	III to EN 60 664-1			
	Pollution degree	2 to EN 60 664-1			
<b>KNX safety extra low voltage</b>	SELV 24 V DC				
<b>Temperature range</b>	Operation	- 5 °C...+45 °C			
	Storage	-25 °C...+55 °C			
	Transport	-25 °C...+70 °C			

# ABB i-bus<sup>®</sup> KNX

## Device technology

<b>Ambient conditions</b>	Maximum air humidity	95 %, no condensation allowed			
<b>Design</b>	Modular installation device (MDRC)	Modular installation device, ProM			
	SA/S type	2.16.6.1	4.16.6.1	8.16.6.1	12.16.6.1
	Dimensions	90 x W x 64.5 mm (H x W x D)			
	Width W in mm	36	72	144	216
	Mounting width in units (18 mm modules)	2	4	8	12
	Mounting depth in mm	64.5	64.5	64.5	64.5
<b>Weight</b>	in kg	0.2	0.34	0.64	0.83
<b>Mounting</b>	On 35 mm mounting rail	To EN 60 715			
<b>Mounting position</b>	As required				
<b>Housing/color</b>	Plastic housing, gray				
<b>Approvals</b>	KNX to EN 50 090-1, -2	Certification			
<b>CE mark</b>	in accordance with the EMC guideline and low voltage guideline				

<sup>1)</sup> Further information concerning electrical endurance to IEC 60 947-4-1 can be found at: [AC1, AC3, AX, C-load specifications](#), p. 43

<sup>2)</sup> The maximum inrush current peak may not be exceeded.

<sup>3)</sup> The specifications apply only after the bus voltage has been applied to the device for at least 30 seconds. Typical relay delay is approx. 20 ms.

### 2.6.2 Lamp output load 16/20 A

<b>Lamps</b>	Incandescent lamp load	3,680 W
<b>Fluorescent lamps T5/T8</b>	Uncorrected	3,680 W
	Parallel compensated	2,500 W
	DUO circuit	3,680 W
<b>Low-voltage halogen lamps</b>	Inductive transformer	2,000 W
	Electronic transformer	2,500 W
	Halogen lamps 230 V	3,680 W
<b>Dulux lamp</b>	Uncorrected	3,680 W
	Parallel compensated	3,000 W
<b>Mercury-vapor lamp</b>	Uncorrected	3,680 W
	Parallel compensated	3,680 W
<b>Switching capacity (switching contact)</b>	Maximum peak inrush current $I_p$ (150 $\mu$ s)	600 A
	Maximum peak inrush current $I_p$ (250 $\mu$ s)	480 A
	Maximum peak inrush current $I_p$ (600 $\mu$ s)	300 A
<b>Number of electronic ballasts (T5/T8, single element)<sup>1)</sup></b>	18 W (ABB EVG 1 x 18 SF)	26 <sup>2)</sup>
	24 W (ABB EVG-T5 1 x 24 CY)	26 <sup>2)</sup>
	36 W (ABB EVG 1 x 36 CF)	22
	58 W (ABB EVG 1 x 58 CF)	12 <sup>2)</sup>
	80 W (Helvar EL 1 x 80 SC)	10 <sup>2)</sup>

<sup>1)</sup> For multiple element lamps or other types, the number of electronic ballasts must be determined using the peak inrush current of the electronic ballasts, see [Ballast calculation](#), p. 42.

<sup>2)</sup> The number of ballasts is limited by protection with B16 circuit-breakers.

# ABB i-bus<sup>®</sup> KNX

## Device technology

Device type	Application program	Maximum number of communication objects	Maximum number of group addresses	Maximum number of associations
SA/S 2.16.6.1	Switch 2f 16CS/...*	40	254	254
SA/S 4.16.6.1	Switch 4f 16CS/...*	76	254	254
SA/S 8.16.6.1	Switch 8f 16CS/...*	148	254	254
SA/S 12.16.6.1	Switch 12f 16CS/...*	220	254	254

\* ... = current version number of the application program

### Please note

ETS and the current version of the device application program are required for programming. The current application program is available for download at [www.abb.com/knx](http://www.abb.com/knx). After import into ETS it can be found under *ABB/Output/Binary output xf 16CS/...* \* (x = 2, 4, 8 or 12). The device does not support the locking function of a KNX device in ETS. If you inhibit access to all of the project devices by using a *BCU code*, it has no effect on this device. Data can still be read and programmed.

### Important

The Switch Actuator types SA/S x.16.6.1 differentiate from the predecessor types SA/S x.16.5S by new hardware and software. While there have been few changes to the functions of the software, the hardware has been redesigned for load currents up to 20 A. Furthermore, the current detection has been optimized and its accuracy has been enhanced by a factor of four. Existing projects can be converted to ensure operation with the new hardware / software. **For further information see:** [Conversion of previous application program versions](#), p. 53.

For faster and simpler commissioning, it is also possible to copy the parameter settings of the outputs to others or to exchange them with another output. **For further information see:** [Copying and exchanging parameter settings](#), p. 57.

### Please note

Only load currents with a sine wave characteristic can be detected correctly. On other signal types, e.g. phase angle or inverse phase angle control signals, the detected current value is distorted. In this case, the measured value is meaningless.

Current values less than 20 mA are indicated as a 0 mA value via KNX. For small load currents that are just above the minimum detection threshold of 20 mA, it is possible that a value of 0 mA is displayed due to the inaccuracies, even though a current is flowing.

### Example

A current of 25 mA is flowing. The Switch Actuator detects 5 mA due to the tolerances. This value is less than the minimum current detection limit of 20 mA and is thus sent as a 0 mA value via KNX.

### Important

The current detection and monitoring function should not be used for safety-related applications. The Switch Actuator cannot assume the function of a circuit-breaker or RCD (earth-leakage circuit breaker). If the load current detection is used for equipment fault detection that only causes a slight change of under 30 mA, mains voltage and current fluctuations due to ambient influences, e.g. temperature, natural ageing of the device or a non-sinusoidal current, play a significant role. Even when the current changes are detected by the Switch Actuator, the detected current changes do not necessarily mean that a device has malfunctioned.



## 2.6.3

Connection schematic SA/S x.16.6.1

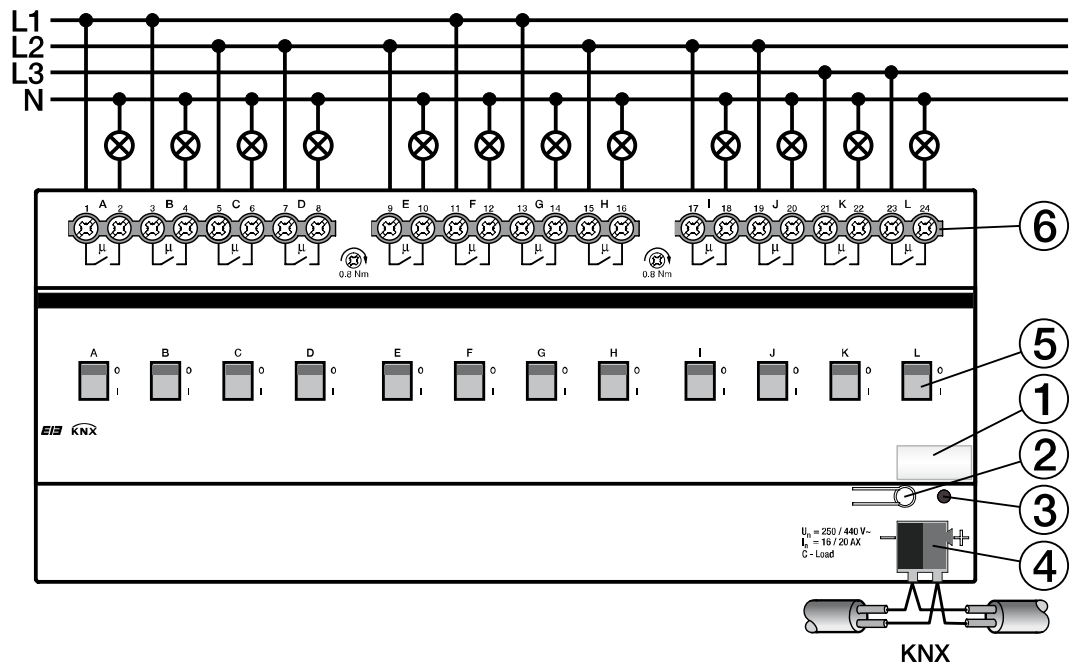

- 1 Label carrier
- 2 Programming button
- 3 Programming LED
- 4 Bus connection terminal
- 5 Contact position display and manual operation
- 6 Load current circuits, for every 2 connection terminals



**Danger**

Touch voltages.  
Danger of injury.  
Observe all-pole disconnection.

## 2.6.4 Dimension drawing SA/S x.16.6.1

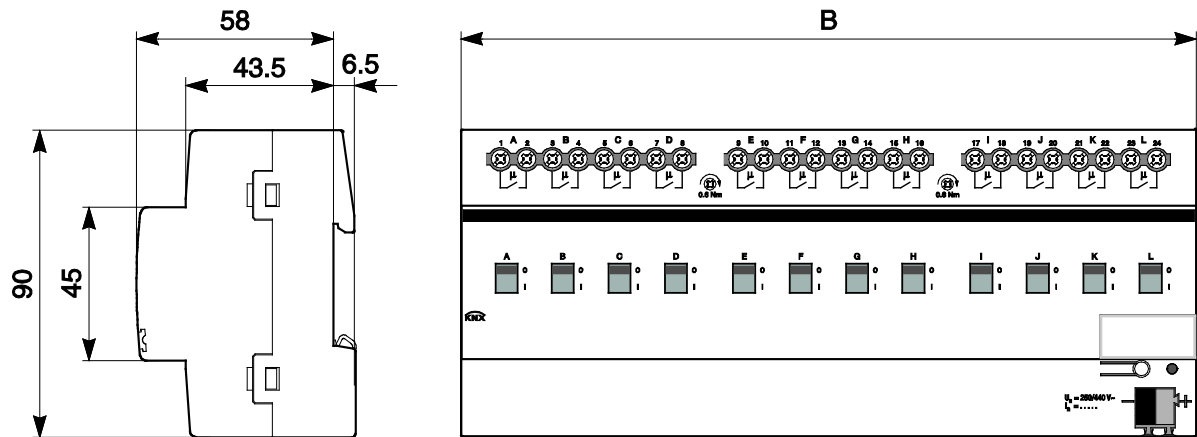

2CDC 072 019 F0013

	SA/S 2.16.6.1	SA/S 4.16.6.1	SA/S 8.16.6.1	SA/S 12.16.6.1
Width W	36 mm	72 mm	144 mm	216 mm
Mounting width (18 mm modules)	2 units	4 units	8 units	12 units

## 2.7 Overview of switching performance

The following table shows the switching capacities, lamp loads and/or the number of lamps that can be connected to each contact.

	SA/S 4.6.1.1 SA/S 8.6.1.1 SA/S 12.6.1.1	SA/S 2.6.2.1 SA/S 4.6.2.1 SA/S 8.6.2.1 SA/S 12.6.2.1	SA/S 2.10.2.1 SA/S 4.10.2.1 SA/S 8.10.2.1 SA/S 12.10.2.1	SA/S 2.16.2.1 SA/S 4.16.2.1 SA/S 8.16.2.1 SA/S 12.16.2.1	SA/S 2.16.5.1 SA/S 4.16.5.1 SA/S 8.16.5.1 SA/S 12.16.5.1	SA/S 2.16.6.1 SA/S 4.16.6.1 SA/S 8.16.6.1 SA/S 12.16.6.1
<b>I<sub>n</sub> rated current (A)</b>	6 A	6 AX	10 AX	16 A	16/20 AX C-load	16/20 AX C-load
<b>U<sub>n</sub> rated voltage (V)</b>	250/440 V AC	250/440 V AC	250/440 V AC	250/440 V AC	250/440 V AC	250/440 V AC
<b>AC1 operation (cos φ = 0.8) EN 60 947-4-1</b>	6 A	6 A	10 A	16 A	20 A	20 A
<b>AC3 operation (cos φ = 0.45) EN 60 947-4-1</b>	6 A	6 A	8 A	<sup>-4)</sup>	16 A	16 A
<b>C-load switching capacity</b>	–	–	–	–	20 A	20 A
<b>Fluorescent lighting load AX to EN 60 669-1</b>	6 A (35 μF) <sup>3)</sup>	6 AX (140 μF) <sup>3)</sup>	10 AX (140 μF) <sup>3)</sup>	16 A (70 μF) <sup>3)</sup>	20 AX (200 μF) <sup>3)</sup>	20 AX (200 μF) <sup>3)</sup>
<b>Minimum switching capacity</b>	10 mA/12 V	100 mA/12 V	100 mA/12 V	100 mA/12 V	100 mA/12 V	100 mA/12 V
<b>DC current switching capacity (ohmic load)</b>	7 A/24 V =	6 A/24 V =	10 A/24 V =	16 A/24 V =	20 A/24 V =	20 A/24 V =
<b>Mechanical lifetime</b>	> 10 <sup>7</sup>	> 3 x 10 <sup>6</sup>	> 3 x 10 <sup>6</sup>	> 3 x 10 <sup>6</sup>	> 10 <sup>6</sup>	> 10 <sup>6</sup>
<b>Electrical endurance to IEC 60947-4-1:</b>						
– Rated current AC1 (240V/0.8)	100,000	100,000	100,000	100,000	100,000	100,000
– Rated current AC3 (240V/0.45)	15,000	30,000	30,000	30,000	30,000	30,000
– Rated current AC5a (240V/0.45)	15,000	30,000	30,000	30,000	30,000	30,000
<b>Incandescent lamp load at 230 V AC</b>	1,200 W	1,380 W	2,500 W	2,500 W	3,680 W	3,680 W
<b>Fluorescent lamps T5/T8:</b>						
– Uncompensated	800 W	1,380 W	2,500 W	2,500 W	3,680 W	3,680 W
– Parallel compensated	300 W	1,380 W	1,500 W	1,500 W	2,500 W	2,500 W
– DUO circuit	350 W	1,380 W	1,500 W	1,500 W	3,680 W	3,680 W
<b>Low-voltage halogen lamps</b>						
– inductive transformer	800 W	1,200 W	1,200 W	1,200 W	2,000 W	2,000 W
– electronic transformer	1,000 W	1,380 W	1,500 W	1,500 W	2,500 W	2,500 W
<b>Halogen lamps 230 V</b>	1,000 W	1,380 W	2,500 W	2,500 W	3,680 W	3,680 W
<b>Dulux lamps (energy-saving lamps):</b>						
– Uncompensated	800 W	1,100 W	1,100 W	1,100 W	3,680 W	3,680 W
– Parallel compensated	800 W	1,100 W	1,100 W	1,100 W	3,000 W	3,000 W
<b>Mercury-vapor lamps:</b>						
– Uncompensated	1,000 W	1,380 W	2,000 W	2,000 W	3,680 W	3,680 W
– Parallel compensated	800 W	1,380 W	2,000 W	2,000 W	3,000 W	3,000 W
<b>Sodium vapor lamps:</b>						
– Uncompensated	1,000 W	1,380 W	2,000 W	2,000 W	3,680 W	3,680 W
– Parallel compensated	800 W	1,380 W	2,000 W	2,000 W	3,000 W	3,000 W
<b>Max. peak inrush current I<sub>p</sub> (150 μs)</b>	200 A	400 A	400 A	400 A	600 A	600 A
<b>Max. peak inrush current I<sub>p</sub> (250 μs)</b>	160 A	320 A	320 A	320 A	480 A	480 A
<b>Max. peak inrush current I<sub>p</sub> (600 μs)</b>	100 A	200 A	200 A	200 A	300 A	300 A
<b>Number of electronic ballasts (T5/T8, single element):<sup>2)</sup></b>						
<b>18 W (ABB EVG 1 x 18 CF)</b>	10 EBUs	23 EBUs	23 EBUs	23 EBUs	26 <sup>1)</sup> EBUs	26 <sup>1)</sup> EBUs
<b>24 W (ABB EVG 1 x 24 CY)</b>	10 EBUs	23 EBUs	23 EBUs	23 EBUs	26 <sup>1)</sup> EBUs	26 <sup>1)</sup> EBUs
<b>36 W (ABB EVG 1 x 36 CF)</b>	7 EBUs	14 EBUs	14 EBUs	14 EBUs	22 EBUs	22 EBUs
<b>58 W (ABB EVG 1 x 58 CF)</b>	5 EBUs	11 EBUs	11 EBUs	11 EBUs	12 <sup>1)</sup> EBUs	12 <sup>1)</sup> EBUs
<b>80 W (Helvar EL 1 x 80 SC)</b>	3 EBUs	10 EBUs	10 EBUs	10 EBUs	12 <sup>1)</sup> EBUs	12 <sup>1)</sup> EBUs

<sup>1)</sup> The number of ballasts (EBUs) is limited by protection with B16/20 A circuit-breakers.

<sup>2)</sup> For multiple element lamps or other types the number of electronic ballasts must be determined using the peak inrush current of the ballasts.

<sup>3)</sup> The maximum inrush current peak may not be exceeded.

<sup>4)</sup> Not intended for AC3 operation; maximum AC3 current see [Technical data](#), from p. 9.

## 2.8 Ballast calculation

The electronic ballast is a device for operating gas discharge lamps, e.g. fluorescent lamps. During normal operation, it converts the mains voltage to an optimum operating voltage for gas discharge lamps. It also enables them to ignite (start) via capacitor circuitry.

With the original choke/starter circuitry the lamps switch on consecutively, with the electronic ballast all fluorescent lamps switch on practically simultaneously. If switch-on occurs at the mains voltage peak, the buffer capacitors of the electronic ballast cause a high but very short current pulse. When using several ballasts on the same circuit, the simultaneous charging of the capacitors may result in very large system inrush currents.

This peak inrush current  $I_p$  is to be considered when designing the switch contacts as well as when selecting the respective circuit protection. The effects of the electronic ballast peak inrush current and the associated limitation of the number of electronic ballasts on the SA/S are examined below.

The inrush current of the electronic ballast depends not only on the wattage but also on the type, the number of elements (lamps) and on the manufacturer. For this reason, the given maximum number of connectible electronic ballasts per output can only relate to a defined type of electronic ballast. For a different ballast type, this value can only represent an estimation.

In order to properly estimate the number of electronic ballasts, the peak inrush current  $I_p$  and the associated pulse width of the electronic ballast must be known. In the meantime, these values are stated by manufacturers in the technical data or are available on request.

Typical values for single element electronic ballasts with T5/T8 lamps are:  
Peak inrush current 15...50 A with a pulse time of 120...200  $\mu$ s.

The Switch Actuator relays have the following maximum starting values:

	SA/S 4.6.1.1	SA/S 2.6.2.1	SA/S 2.10.2.1	SA/S 2.16.2.1	SA/S 2.16.5.1	SA/S 2.16.6.1
	SA/S 8.6.1.1	SA/S 4.6.2.1	SA/S 4.10.2.1	SA/S 4.16.2.1	SA/S 4.16.5.1	SA/S 4.16.6.1
	SA/S 12.6.1.1	SA/S 8.6.2.1	SA/S 8.10.2.1	SA/S 8.16.2.1	SA/S 8.16.5.1	SA/S 8.16.6.1
		SA/S 12.6.2.1	SA/S 12.10.2.1	SA/S 12.16.2.1	SA/S 12.16.5.1	SA/S 12.16.6.1
Max. peak inrush current $I_p$ (150 $\mu$ s)	200 A	400 A	400 A	400 A	600 A	600 A
Max. peak inrush current $I_p$ (250 $\mu$ s)	160 A	320 A	320 A	320 A	480 A	480 A
Max. peak inrush current $I_p$ (600 $\mu$ s)	100 A	200 A	200 A	200 A	300 A	300 A

\*) x = 5 or 6, C-load types with and without load current detection

### Caution

Do not exceed the threshold values.

Exceeding the value leads to destruction of the relay, e.g. due to welding.

### Example

ABB i-bus<sup>®</sup> ballast 1 x 58 CF

Peak inrush current  $I_p = 33.9 \text{ A}$  (147.1  $\mu\text{s}$ )

For Switch Actuator SA/S 4.16.6.1 this results in:

maximum number of electronic ballasts/output =  $600 \text{ A}/34 \text{ A} = 17$  electronic ballasts

This number has been limited to 12 electronic ballasts in conjunction with a B16 miniature circuit breaker. If more electronic ballasts are connected, the miniature circuit breaker may trip during switch on.

For Switch Actuator SA/S 4.6.1.1 this results in:

maximum number of electronic ballasts/output =  $200 \text{ A}/34 \text{ A} = 5$  electronic ballasts

## 2.9

### AC1, AC3, AX, C-load specifications

In Intelligent Building Control, different switching capabilities and performance specifications, required by special applications, have become established in industrial and residential systems. These performance specifications are rooted in the respective national and international standards. The tests are defined to simulate typical applications, e.g. motor loads (industrial) or fluorescent lamps (residential).

Specifications AC1 and AC3 are switching performance specifications which have become established in the industrial field.

Typical application:

AC1 – Non-inductive or slightly inductive loads, resistance furnaces  
(relates to switching of resistive loads,  $\cos \varphi = 0.8$ )

AC3 – Squirrel-cage motors: starting or switching off during running  
(relates to (inductive) motor load,  $\cos \varphi = 0.45$ )

AC5a – Switching of electric discharge lamps

These switching performances are defined in standard EN 60 947-4-1 *Contactors and motor-starters – Electromechanical contactors and motor-starters*.

The standard describes starters and/or contactors that were originally used primarily in industrial applications.

The designation AX has established itself in the field of building services technology.

AX relates to a (capacitive) fluorescent lighting load.

Switchable capacitive loads (200  $\mu\text{F}$ , 140  $\mu\text{F}$ , 70  $\mu\text{F}$  or 35  $\mu\text{F}$ ) are referred to in conjunction with fluorescent lamp loads.

This switching capacity refers to standard EN 60 669 *Switches for household and similar fixed electrical installations – General requirements*, which deals primarily with applications in building services engineering. For 6 A devices, a test with 70  $\mu\text{F}$  is required and for devices exceeding 6 A, a test with 140  $\mu\text{F}$ .

The switching capacity specifications AC and AX are not directly comparable. However, the following switching capacity capability can still be determined:

The lowest switching capacity corresponds with the specification AC1 – mainly for ohmic loads.

The following switching capacity should be rated higher AX – fluorescent lamp loads, under the standard: 70 µF (6 A), 140 µF (10 A, 16 A).

The highest switching capacity is designated by AC3 – motor loads, C-load – fluorescent lamp loads (200 µF).

Both specifications are almost equivalent. This means that a device which has met the test for AC3 under EN 60 947 will most probably meet those under EN 60 669 with 200 µF.

In conclusion, generally speaking:

- Users or customers primarily involved with industrial applications will tend to refer to AC3 switching capacities.
- Users involved with building or lighting technology will more often than not refer to an AX switching capacity or C-load (200 µF loads).

The switching capacity differences must be considered when selecting a Switch Actuator.

## 2.10 Current detection specifications

The Switch Actuators with current detection are recognizable by a number 6 as the third number of the type designation, e.g. SA/S 2.16.6.1.

This is a Switch Actuator with integrated load current detection.

Each output features its own current detection with evaluation electronics, which can be parameterized separately.

For further information see: [Parameter window A: Current Detection](#), p. 101

The current recognition detects sinusoidal load currents with a 45-60 Hz frequency range. Non-sinusoidal currents, e.g. phase angle varied or distorted currents, cause a measurement error depending on the curve type. If a DC current is superimposed, the measurement error is again considerably larger. Phase angle varied currents are generated, for example, by a current rectifier.

The current detection principle in the Switch Actuator is based on the conversion of sinusoidal load currents by a transformer. On the secondary side of the transformer, the transferred value is rectified and smoothed by an RC element. The resulting value is multiplied with the fixed factor  $1/\sqrt{2}$ , producing an RMS value. The factor  $1/\sqrt{2}$  is derived from the crest factor  $\hat{U}/U_{\text{rms}} = \sqrt{2}$  for a sinusoidal curve type.

# ABB i-bus<sup>®</sup> KNX

## Device technology

For a non-sinusoidal curve type, the resulting values can diverge significantly from the real RMS value. This measurement method is used in most commercially available analog and digital multimeters that are calibrated for sinusoidal curve types.

In this case, a true RMS meter or a “non-true RMS meter” are frequently referred to, e.g. METRAHit 13S.

Please note
With non-sinusoidal currents, there are considerable differences between a high-quality true RMS meter and the displayed values of the SA/S. For this reason, comparative measurements should be taken using a meter that is also calibrated for sinusoidal AC currents.

For technical reasons, only currents exceeding 20 mA can be displayed. Interference is suppressed by an RC element, and the displayed value is stabilized. The RC element has a time constant  $\tau$  of around 300 ms. The current values are scanned cyclically with a scanning frequency of 320 ms. Thus a change in the current can be safely detected every 320 ms and sent via the bus if required. The near exact value is displayed after  $5 \tau \approx 1.5$  s.

The following technical specifications apply for current detection:

Detection range:	0.02...20 A
Accuracy:	+/- 2 % of actual current value +/- 20 mA
Time constant:	300 ms
Scanning rate:	320 ms
Load current $I_{\text{Load AC}}$ :	0...20 A, sinusoidal
$I_{\text{Load DC}}$ :	Is not detected
Frequency range:	45...65 Hz
Ambient temperature:	-5 °C...+40 °C

Examples	
Detected current value	Max. inaccuracy
300 mA	+/- 26 mA
2 A	+/- 60 mA
16 A	+/- 340 mA
20 A	+/- 420 mA

For every output, the determined current values can be represented via a 2 or 4 byte value output object. The currents are represented in mA as counter values (2 byte, DTP 7.012) or floating values (4 byte, DTP 14.019).

It is possible to program two threshold values for each output. With an overshoot or undershoot of the current threshold value a 1 bit telegram is sent via the bus. Thus for example, the failure of equipment can be detected and displayed.

With relatively small current values (< 30 mA), natural deviations in the electrical system will be immediately noticeable, e.g. natural ageing of the equipment, voltage fluctuations through differing load levels during the day as well as distortions of the sinusoidal load current, e.g. through switching actions or frequency inverters.

The ideal observation, i.e. where the current consumption of the equipment does not change with temperature fluctuations, operating voltage deviations and ageing, should always be inspected in the actual system. The changes of the ambient conditions in practice and the associated changes in current consumption and the monitored equipment must be considered. As ambient influences cannot be eliminated in practice, detection via a current threshold model is only viable if a current change caused by tolerances and ambient influences in normal operation is less than the current change caused by equipment failure.

Recommended approach when monitoring loads that are close to the detection tolerances of the SA/S current detection:

- Connect the complete circuit to the SA/S output.
- Close the circuit and operate loads in the typical operating range.
- In ETS, set the data point types of the communication object and start the ETS project group monitor in order to display the current value.
- Observe current value  $I_A$  via KNX until a constant current is indicated.
- Cause equipment failure and observe the current value  $I_F$  again.
- Determine the difference in current  $I_D = I_A - I_F$ .
- Compare the difference in current  $I_D$  with the current detection tolerances. The current difference must be significantly larger than the accuracy of the current detection (2 % of  $I_A$  +/- 20 mA).
- Set the current threshold in SA/S so that it is as near as possible to the determined failure current:  $I_A - \frac{1}{2} I_D$  has proven useful.



### 2.11 Assembly and installation

ABB i-bus<sup>®</sup> Switch Actuators are modular installation devices for installation in the distribution board on 35 mm EN 60 715 mounting rails.

The mounting position can be selected as required.

The electrical connection is implemented using screw terminals. The connection to the bus is implemented using the supplied bus connection terminal. The terminal designations are located on the housing.

The device is ready for operation after connection to the bus voltage.

Accessibility of the devices for the purpose of operation, testing, visual inspection, maintenance and repair must be provided compliant to VDE 0100-520.

#### Commissioning requirements

To commission the Switch Actuators, a PC with ETS and an interface, e.g. USB or IP, are required. The device is ready for operation after connection to the bus voltage.

The installation and commissioning may only be carried out by electrical specialists. The appropriate standards, guidelines, regulations and specifications should be observed when planning and setting up electrical installations.

- Protect the device from damp, dirt and damage during transport, storage and operation.
- Only operate the device within the specified technical data!
- The device should only be operated in an enclosed housing (distribution board)!

#### Manual operation

With the exception of SA/S x.6.1.1 variant, the Switch Actuators can be manually operated. They can be switched on or off with a button on the relay. The button simultaneously indicates the contact position.

Important
<p>The Switch Actuator does not monitor manual actuation electrically, and therefore cannot react discretely to a manual operation.</p> <p>From a power engineering point of view, the relay is only actuated with a switching pulse if the last known relay position set by the bus has changed. As a consequence, after a one-off manual switching operation, a switch telegram received via the bus triggers no contact changeover because the switch actuator assumes that no changeover has taken place and that the correct contact position is still set.</p> <p>An exception to this situation is after bus voltage failure and recovery. In both cases, the relay position is recalculated based on the parameterization and set independently of the contact position.</p>

### **Supplied state**

The device is supplied with the physical address 15.15.255. The application program is preloaded. It is therefore only necessary to load group addresses and parameters during commissioning.

However, the complete application program can be reloaded if required. Downloads may take longer after a change of application program, a discharge or an aborted download.

### **Download response**

Depending on the PC which is used, the progress bar for the download may take up to one and a half minutes to appear, due to the complexity of the device.

### **Assignment of the physical address**

The assignment and programming of the physical address is carried out in ETS.

The device features a *Programming* button for assignment of the physical device address. The red *Programming* LED lights up after the button has been pushed. It switches off as soon as ETS has assigned the physical address or the *Programming* button is pressed again.

### **Cleaning**

If devices become dirty they can be cleaned using a dry cloth or a cloth dampened with a soapy solution. Corrosive agents or solutions should never be used.

### **Maintenance**

The device is maintenance-free. No repairs should be carried out by unauthorized personnel if damage occurs, e.g. during transport and/or storage.

## 3 Commissioning

All SA/S devices and each of their outputs have the same function, with the exception of current detection. It is thus possible, depending on the application, to freely define every output and parameterize it accordingly.

The applications feature the same appearance and the same parameter window. This significantly simplifies engineering and programming for ABB i-bus<sup>®</sup> KNX Switch Actuators.

Current detection is only integrated in types SA/S x.16.6.1.

Every Switch Actuator has its own application program with the same functions, whereby devices with current detection feature additional parameters and communication objects for the current detection.

## 3.1 Overview

The following table provides an overview of the functions of the Switch Actuators and their application programs:

	SA/S 4.6.1.1 SA/S 8.6.1.1 SA/S 12.6.1.1	SA/S 2.6.2.1 SA/S 4.6.2.1 SA/S 8.6.2.1 SA/S 12.6.2.1	SA/S 2.10.2.1 SA/S 4.10.2.1 SA/S 8.10.2.1 SA/S 12.10.2.1	SA/S 2.16.2.1 SA/S 4.16.2.1 SA/S 8.16.2.1 SA/S 12.16.2.1	SA/S 2.16.5.1 SA/S 4.16.5.1 SA/S 8.16.5.1 SA/S 12.16.5.1	SA/S 2.16.6.1 SA/S 4.16.6.1 SA/S 8.16.6.1 SA/S 12.16.6.1
Type of installation	MDRC	MDRC	MDRC	MDRC	MDRC	MDRC
Number of outputs	4/8/12	2/4/8/12	2/4/8/12	2/4/8/12	2/4/8/12	2/4/8/12
Module width (units)	4/6/8	2/4/8/12	2/4/8/12	2/4/8/12	2/4/8/12	2/4/8/12
Manual operation	–	■	■	■	■	■
Contact position indicator	–	■	■	■	■	■
I <sub>n</sub> rated current (A)	6 A	6 AX	10 AX	16 A	16/20 A	16/20 A
Current detection	–	–	–	–	–	■
<b>Switch function</b>						
– ON/OFF delay	■	■	■	■	■	■
– Staircase lighting	■	■	■	■	■	■
– Warning before end of staircase lighting	■	■	■	■	■	■
– Staircase lighting time set via object	■	■	■	■	■	■
– Flashing	■	■	■	■	■	■
– Switch response can be set (N.O./N.C.)	■	■	■	■	■	■
– Threshold values	■	■	■	■	■	■
<b>Current detection</b>						
– Threshold value monitoring	–	–	–	–	–	■
– Measured value detection	–	–	–	–	–	■
<b>Scene function</b>	■	■	■	■	■	■
<b>Logic function</b>						
– Logic object AND	■	■	■	■	■	■
– Logic object OR	■	■	■	■	■	■
– Logic object XOR	■	■	■	■	■	■
– Gate function	■	■	■	■	■	■
<b>Priority object / forced operation</b>	■	■	■	■	■	■
<b>Heating/fan control</b>						
– Switch ON/OFF (2 step)	■	■	■	■	■	■
– Cyclical fault monitoring	■	■	■	■	■	■
– Automatic purging	■	■	■	■	■	■
Fan coil control <sup>1)</sup>	■	■	■	■	■	■
Special functions						
Preference on bus voltage failure/recovery	■	■	■	■	■	■
– Status messages	■	■	■	■	■	■

<sup>1)</sup> See special ABB i-bus® KNX devices for the HVAC area, e.g. Valve Drive actuator, Fan/Fan Coil actuator or Fan Coil actuator.

■ = possible functions

# ABB i-bus<sup>®</sup> KNX Commissioning

The following application programs are available for the Switch Actuators:

Device type	Application program	Maximum number of communication objects	Maximum number of group addresses	Maximum number of associations
SA/S 4.6.1.1	Switch 4f 6A/...*	64	254	254
SA/S 8.6.1.1	Switch 8f 6A/...*	124	254	254
SA/S 12.6.1.1	Switch 12f 6A/...*	184	254	254
SA/S 2.6.2.1	Switch 2f 6AM/...*	34	254	254
SA/S 4.6.2.1	Switch 4f 6AM/...*	64	254	254
SA/S 8.6.2.1	Switch 8f 6AM/...*	124	254	254
SA/S 12.6.2.1	Switch 12f 6AM/...*	184	254	254
SA/S 2.10.2.1	Switch 2f 10A/...*	34	254	254
SA/S 4.10.2.1	Switch 4f 10A/...*	64	254	254
SA/S 8.10.2.1	Switch 8f 10A/...*	124	254	254
SA/S 12.10.2.1	Switch 12f 10A/...*	184	254	254
SA/S 2.16.2.1	Switch 2f 16A/...*	34	254	254
SA/S 4.16.2.1	Switch 4f 16A/...*	64	254	254
SA/S 8.16.2.1	Switch 8f 16A/...*	124	254	254
SA/S 12.16.2.1	Switch 12f 16A/...*	184	254	254
SA/S 2.16.5.1	Switch 2f 16C/...*	34	254	254
SA/S 4.16.5.1	Switch 4f 16C/...*	64	254	254
SA/S 8.16.5.1	Switch 8f 16C/...*	124	254	254
SA/S 12.16.5.1	Switch 12f 16C/...*	184	254	254
SA/S 2.16.6.1	Switch 2f 16CS/...*	40	254	254
SA/S 4.16.6.1	Switch 4f 16CS/...*	76	254	254
SA/S 8.16.6.1	Switch 8f 16CS/...*	152	254	254
SA/S 12.16.6.1	Switch 12f 16CS/...*	220	254	254

\*... = ETS and the current version of the device application program are required for programming. The current application program is available for download at [www.abb.com/knx](http://www.abb.com/knx). After import into ETS it is available under *ABB/Output/Binary output xf /...* (x = 2, 4, 8 or 12).

## Please note

This product manual describes all the current 2/4/8 and 12-fold Switch Actuators. These devices have 2/4/8 or 12 outputs respectively. However, as the functions for all outputs are identical, only the functions of output A will be described.

Where information in the product manual refers to all outputs, the description output A...X is used. 2-fold corresponds to outputs A...B, 4-fold corresponds to outputs A...D, 8-fold corresponds to outputs A...H and 12-fold corresponds to outputs A...L.

The variants with current detection feature an additional parameter page as well as additional communication objects for this function.

The following operating modes are available for each output of a Switch Actuator:

<p><b>Switch actuator</b></p>	<p>For "normal" switching, e.g. of lighting. The output is controlled directly via the communication object <i>Switch</i>. A large number of additional functions (time, logic, safety, etc.) are possible. <b>For further information see:</b> <a href="#">Planning and application</a>, p. 141</p>
<p><b>Heating actuator</b></p>	<p>For control of heating valves, e.g. in an individual room temperature control system. A room thermostat sends a control value which the output uses to control the valve, e.g. as a 2-step control. <b>For further information see:</b> <a href="#">Planning and application</a>, p. 141</p>

<p><b>Please note</b></p>
<p>With the introduction of optimized current detection, on all Switch Actuator types the nomenclature for status messages, e.g. <i>Telegr.status switch</i>, <i>Telegr.RTR fault</i>, has been converted to the current nomenclature without <i>Telegr.</i>, e.g. <i>Status Switch</i>, <i>RTR fault</i>.</p>

# ABB i-bus® KNX Commissioning

## 3.1.1 Conversion of previous application program versions

For ABB i-bus® KNX devices, using ETS3 or higher it is possible to assume the parameter settings and group addresses from earlier application programs.

<b>Please note</b>
Default values for newly added parameters are set after conversion.

### 3.1.1.1 Conversion options

The following application programs can be converted:

Device type Source device	Application name Source device	Convertible to	Device type Target device	Application name Target device
SA/S 2.16.5S	Switch 2f 16CS/2.0	→	SA/S x.6.1.1	Switch xf 6A/3.2
SA/S 4.16.5S	Switch 4f 16CS/2.0	→	SA/S x.6.2.1	Switch xf 6M/3.2
SA/S 8.16.5S	Switch 8f 16CS/2.0	→	SA/S x.10.2.1	Switch xf 10A/3.2
			SA/S x.16.2.1	Switch xf 16A/3.2
			SA/S x.16.5.1	Switch xf 16C/3.2
			SA/S x.16.6.1	Switch xf 16CS/3.2
SA/S 12.16.5	Switch 12f 16C/2.0	not convertible		
SA/S 2.20.1S	Switch 2f 20S/2.0	→	SA/S x.6.1.1	Switch xf 6A/3.2
SA/S 4.20.1S	Switch 4f 20S/2.0	→	SA/S x.6.2.1	Switch xf 6M/3.2
SA/S 8.20.1S	Switch 8f 20S/2.0	→	SA/S x.10.2.1	Switch xf 10A/3.2
			SA/S x.16.2.1	Switch xf 16A/3.2
			SA/S x.16.5.1	Switch xf 16C/3.2
			SA/S x.16.6.1	Switch xf 16CS/3.2
SA/S 12.20.1	Switch 12f 20A/2.0	not convertible		
SA/S x.16.6.1	Switch xf 16CS/3.0, 3.1 or 3.2	→	SA/S x.16.6.1	Switch xf 16CS/3.2
			SA/S x.16.5.1	Switch xf 16C/3.2
SA/S x.16.5.1	Switch xf 16C/3.1 or 3.2	→	SA/S x.16.2.1	Switch xf 16A/3.2
			SA/S x.10.2.1	Switch xf 10A/3.2
			SA/S x.6.2.1	Switch xf 6M/3.2
SA/S x.16.2.1	Switch xf 16A/3.2	→	SA/S x.6.1.1	Switch xf 6A/3.2
			SA/S x.6.2.1	Switch xf 6M/3.2
			SA/S x.10.2.1	Switch xf 10A/3.2
SA/S x.10.2.1	Switch xf 10A/3.2	→	SA/S x.16.2.1	Switch xf 16A/3.2
			SA/S x.16.5.1	Switch xf 16C/3.2
			SA/S x.16.6.1	Switch xf 16CS/3.2
SA/S x.6.2.1	Switch xf 6M/3.2	→	SA/S x.6.2.1	Switch xf 6M/3.2
SA/S x.6.1.1	Switch xf 6A/3.2	→	SA/S x.6.1.1	Switch xf 6A/3.2
			SA/S x.10.2.1	Switch xf 10A/3.2
			SA/S x.16.2.1	Switch xf 16A/3.2
SA/S x.16.1	Switch xf 16A/2.0	not convertible		
SA/S x.10.1	Switch xf 10A/2.0			
SA/S x.6.1	Switch xf 6A/2.0			

# ABB i-bus<sup>®</sup> KNX Commissioning

The following conversions are possible from the point of view of the target devices:

Device type Target device	Application name Target device	Convertible to	Device type Source device	Application name Source device
		←	SA/S x.16.5S SA/S x.20.1S	Switch xf 16CS/2.0 Switch xf 20S/2.0
SA/S x.16.6.1	Switch xf 16CS/3.2	←	SA/S x.16.6.1 (V1.0) SA/S x.16.6.1 SA/S x.16.5.1 SA/S x.16.2.1 SA/S x.10.2.1	Switch xf 16CS/3.0 Switch xf 16CS/3.1 or 3.2 Switch xf 16C/3.1 or 3.2 Switch xf 16A/3.2 Switch xf 10A/3.2
SA/S x.16.5.1	Switch xf 16C/3.2	←	SA/S x.16.5S (V2.0) SA/S x.20.1S (V2.0)	Switch xf 16CS/2.0 Switch xf 20S/2.0
		←	SA/S x.16.6.1 (V1.0) SA/S x.16.6.1 SA/S x.16.5.1 SA/S x.16.2.1 SA/S x.10.2.1	Switch xf 16CS/3.0 Switch xf 16CS/3.1 or 3.2 Switch xf 16C/3.1 or 3.2 Switch xf 16A/3.2 Switch xf 10A/3.2
SA/S x.16.2.1	Switch xf 16A/3.2	←	SA/S x.16.5S SA/S x.20.1S	Switch xf 16CS/2.0 Switch xf 20S/2.0
		←	SA/S x.16.6.1 (V1.0) SA/S x.16.6.1 SA/S x.16.5.1 SA/S x.16.2.1 SA/S x.10.2.1 SA/S x.6.1.1	Switch xf 16CS/3.0 Switch xf 16CS/3.1 or 3.2 Switch xf 16C/3.1 or 3.2 Switch xf 16A/3.2 Switch xf 10A/3.2 Switch xf 6A/3.2
SA/S x.10.2.1	Switch xf 10A/3.2	←	SA/S x.16.5S SA/S x.20.1S	Switch xf 16CS/2.0 Switch xf 20S/2.0
		←	SA/S x.16.6.1 (V1.0) SA/S x.16.6.1 SA/S x.16.5.1 SA/S x.16.2.1 SA/S x.10.2.1 SA/S x.6.1.1	Switch xf 16CS/3.0 Switch xf 16CS/3.1 or 3.2 Switch xf 16C/3.1 or 3.2 Switch xf 16A/3.2 Switch xf 10A/3.2 Switch xf 6A/3.2
SA/S x.6.2.1	Switch xf 6M/3.2	←	SA/S x.16.6.1 (V1.0) SA/S x.16.6.1 SA/S x.16.5.1 SA/S x.16.2.1 SA/S x.10.2.1 SA/S x.6.2.1 SA/S x.6.1.1	Switch xf 16CS/3.0 Switch xf 16CS/3.1 or 3.2 Switch xf 16C/3.1 or 3.2 Switch xf 16A/3.2 Switch xf 10A/3.2 Switch xf 6M/3.2 Switch xf 6A/3.2
		not convertible	SA/S 12.16.5 SA/S 12.20.5 SA/S x.16.1 SA/S x.10.1 SA/S x.6.1	Switch 12f 16C/2.0 Switch 12f 20A/2.0 Switch xf 16A/2.0 Switch xf 10A/2.0 Switch xf 6A/2.0

The version number in brackets refers to the application program version.



## Important

Usually, the version numbers of our product names match the version number of the application program. Among our Switch Actuators there are some exceptions, e.g. the SA/S 4.16.6.1:

**Product name:** Switch Actuator, 4-fold, 16 A, MDRC (V1.0)

**Application program:** Switch 4f 16CS/3.0

## Important

The Switch Actuator types SA/S x.16.6.1 differentiate from the predecessor types SA/S x.16.5S by new hardware and software.

While there have been few changes to the functions of the software, the hardware has been redesigned for load currents up to 20 A. Furthermore, current detection has been optimized, enhancing its accuracy by a factor of four.

To minimize programming work, with the SA/S x.16.6.1 and SA/S x.16.5.1 it is possible to copy or exchange the device's output parameters.

## Please note

If the number of outputs of the target device is larger than the number of outputs of the source device, only the first outputs of the target device are written with the converted data of the source device. The remaining outputs retain or are reset to the default values. However, the group assignments of the existing communication object do not change.

### 3.1.1.1.1

#### Summary of conversion

- All *Switch.../3.1* or *3.2* applications (SA/S x.16.y.1 with or without current detection) are interchangeable.
- *Switch...CS/2.0* applications (SA/S x.16.5S with current detection) are approved as a source.
- The *Switch 12f 16C/2.0* application (SA/S 12.16.5 12-fold device without current detection) cannot be used as a source.
- The general rules for conversion apply (parameters in the source device that do not exist in the target device are ignored; parameters in the target device that do not exist in the source device retain their default value).
- The *Switch...6M/3.2* application is not recognized as a source by older devices. In other words, the application for the 6 A with manual operation can only be loaded onto a 6 A with manual operation.

# ABB i-bus<sup>®</sup> KNX Commissioning

## 3.1.1.2

### Procedure

- Import the current VD3 file into ETS3 and add a product and its current application program to the project.
- After you have parameterized a device, you can transfer the settings to a second device.
- To do this, right-click on the product and select *Convert* in the context menu.

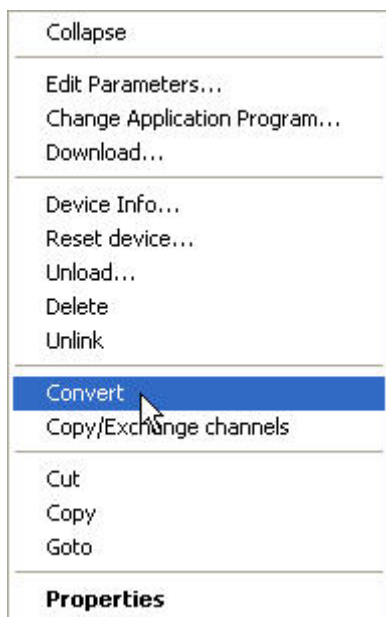

- Then make the desired settings in the Convert dialog.
- Finally, exchange the physical address and delete the old device.

Should you wish only to copy individual channels within a device, use the [Copying and exchanging parameter settings](#) function, p. 57.

## 3.1.2 Copying and exchanging parameter settings

Please note
The output copy and exchange function is integrated into all Switch Actuators.

Parameterization of devices can take a lot of time depending on the complexity of the application and the number of device outputs. To keep commissioning work to the minimum possible, using the function *Copy/Exchange channels*, parameter settings of an output can be copied or exchanged to/with any output. Optionally, the group addresses can be retained, copied or deleted in the target output.

The output copy function is particularly useful with Switch Actuators that have several outputs with the same parameter settings. For example, lighting in a room is frequently controlled in an identical manner. In this case, the parameter settings from output X of a Switch Actuator can be copied to all other outputs or to a particular output of the Switch Actuator. Thus the parameters for this output need not be set separately, which significantly shortens commissioning time.

The exchange of parameter settings is useful e.g. should the outputs be swapped when wiring the terminals. The parameter settings of the incorrectly wired outputs can simply be exchanged, saving time-consuming rewiring.

# ABB i-bus<sup>®</sup> KNX Commissioning

## 3.1.2.1

### Procedure

- Import the current VD3 file into ETS3 and add a product and its current application program to the project.
- Right-click on the product whose outputs you wish to copy or exchange and select *Copy/Exchange channels* in the context menu

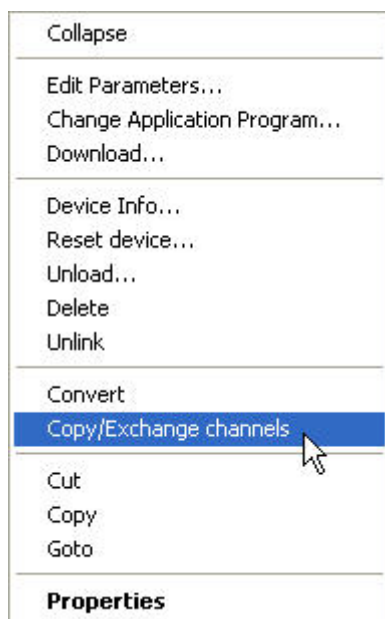

Then make the required settings in the *Copy/Exchange channels* dialog.

#### Please note

When the term “channels” is used in ETS, it means inputs and/or outputs. To make the language of ETS generally valid for as many ABB i-bus<sup>®</sup> devices as possible, the word channels is used in this document.

## 3.1.2.2

### Copy/Exchange channels dialog

Source channel

Destination channels

Output A  
Output B

Output A  
Output B

All None

Keep group addresses in the destination channel unchanged (if possible)

Copy group addresses

Delete group addresses in the destination channel

Copy

Exchange without group addresses

Exchange with group addresses

Delete group addresses

Exchange

OK Cancel

You can see general product information in the upper area of the window.

Below it you will find a selection window for the source channel so that you can mark it. Beside it is the selection window for marking the destination channel(s).

#### Source channel

The source channel selection defines which parameter settings should be copied or exchanged. Only one source channel can be selected at a time.

## Destination channels

By selecting the destination channel(s) you define which channel(s) are to assume the parameter settings of the source channel.

- For the *Exchange* function, only one target output can be selected at a time.
- For the *Copy* function, various destination channels can be selected simultaneously. To do this, press the Ctrl key and mark the required channels, e.g. channel B and H, with the mouse pointer.



With this button, you select all available destination channels, e.g. A...H.



Reset the destination channel selection with this button.

## Copy

The following options can be selected before copying the parameter settings:

- Keep group addresses in the destination channel unchanged (if possible)
- Copy group addresses
- Delete group addresses in the destination channel

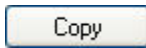

With this button, you copy the settings of the source channel into the target channel(s).

## Exchange

The following options can be selected before exchanging the parameter settings:

- Exchange without group addresses
- Exchange with group addresses
- Delete group addresses

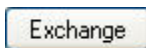

With this button, you exchange the settings of the source channel with those of the destination channel.

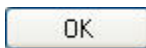

Confirm your selection with this button, and the window closes.

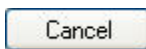

This button, closes the window without accepting the changes.

## 3.2 Parameters

The Switch Actuator is parameterized using Engineering Tool Software (ETS), version ETS2 V1.3 or higher.

In ETS2/ETS3 the application program can be found under ABB/Output/Binary output/Switch xf.

The following sections describe the parameters of the Switch Actuators by their parameter windows. Parameter windows are structured dynamically so that further parameters may be enabled depending on the settings and the function.

The default values of the parameters are underlined, e.g.:

Options:    yes  
              no

### Please note

This product manual describes all the current 2/4/8 and 12-fold Switch Actuators. These devices have 2/4/8 or 12 outputs respectively. However, as the functions for all outputs are identical, only the functions of output A will be described.

Where information in the product manual refers to all outputs, the description output A...X is used. 2-fold corresponds to outputs A...B, 4-fold corresponds to outputs A...D, 8-fold corresponds to outputs A...H and 12-fold corresponds to outputs A...L.

The variants with current detection feature an additional parameter page as well as additional communication objects for this function.

## 3.2.1 Parameter window *General*

Higher level parameters can be set in the *General* parameter window.

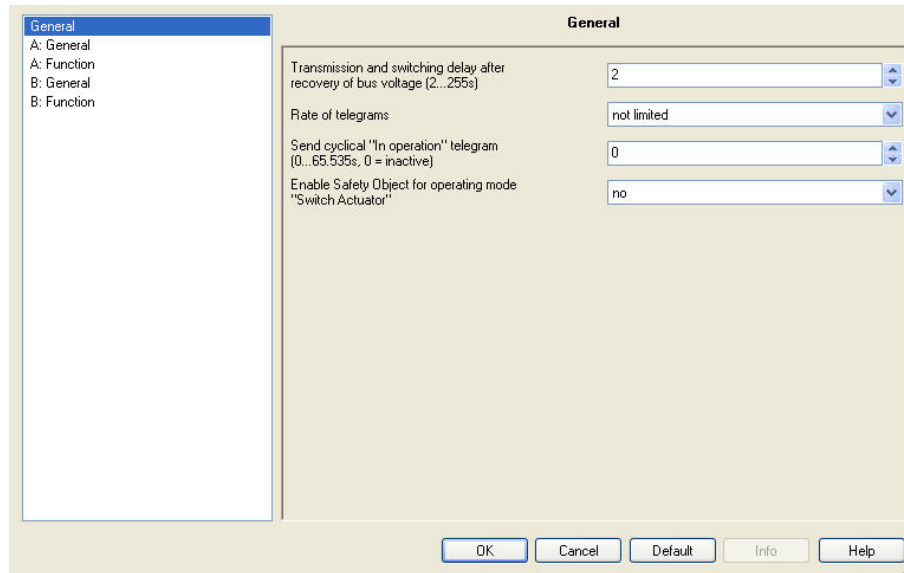

### **Transmission and switching delay time after recovery of bus voltage [2...255s]**

Options:     2...255

During the transmission and switching delay, telegrams are received only. The telegrams are not processed, however, and the outputs remain unchanged. No telegrams are sent via the bus.

After the transmission and switching delay, telegrams are sent and the state of the outputs is set to correspond with the parameterization or the communication object values.

If communication objects are read during the sending and switching delay, e.g. by a visualization system, these read requests are stored, and a response is sent, after the sending and switching delay has been completed.

An initialization time of about two seconds is included in the delay time. The initialization time is the time that the processor requires to be ready to function.

#### **How does the device react on bus voltage recovery?**

After bus voltage recovery, the device always waits for the transmission delay time to elapse before sending telegrams via the bus.



# ABB i-bus<sup>®</sup> KNX Commissioning

## Rate of telegrams

Options:     not limited  
              1 Telegram / Second  
              2 Telegrams / Second  
              3 Telegrams / Second  
              5 Telegrams / Second  
              10 Telegrams / Second  
              20 Telegrams / Second

The load on the bus generated by the device can be limited by the telegram rate. This limit relates to all telegrams sent by the device.

- $x^*$  *Telegrams / Second*: within a second, x telegrams are sent as quickly as possible via the bus.

### Please note

The device counts the number of telegrams sent within a second. As soon as the maximum number of sent telegrams is reached, no further telegrams are sent via KNX until the end of the second. The telegram counter is reset to zero, and sending is allowed again after the second has timed-out. The current communication object value is always sent at the time of transmission.

### Example

Maximum number of sent telegrams = 5,  
20 telegrams are ready to send. The device immediately sends 5 telegrams. The next 5 telegrams are sent after a maximum of 1 second. From this point, a further 5 telegrams are sent via KNX every second.

x = 1, 2, 3, 5, 10 or 20

## Send cyclical "In operation" telegram [0...65,535s, 0 = inactive]

Options:     0...65,535

The communication object *In Operation* indicates that the device on the bus is working properly. This cyclic telegram can be monitored by an external device.

### Please note

After bus voltage recovery, the communication object sends its value after the set sending and switching delay.  
To keep the bus load to a minimum, the longest possible transmission time interval should be selected, based on the application.

## Enable Safety Object for operating mode "Switch Actuator"

Options:     no  
              yes

- yes: Three further parameters appear:

### Function Safety Priority 1

### Function Safety Priority 2

### Function Safety Priority 3

Options:     inactive  
              enabled by object value "0"  
              enabled by object value "1"

#### Please note

The functions and setting options for parameters *Function Safety Priority 2* and *Function Safety Priority 3* are the same as those for parameter *Function Safety Priority 1*.

In *Switch Actuator* operating mode there are three *Function Safety Priority x\** parameters available. For each priority, you can define your own trigger condition (enabling condition) here. With safety activation, the relevant *Safety Priority x\** communication object becomes visible. These communication objects relate to the entire device. However, every output can react differently to the receipt of a telegram. The reaction of the output is parameterized in parameter window *X: Safety* of the respective output.

\*x = 1, 2 or 3

- *inactive*: The Safety Priority x function is not used.
- *enabled by object value "0"*: Safety activation is triggered if communication object *Safety Priority x\** receives a telegram with the value 0. The following parameter appears.
- *enabled by object value "1"*: Safety activation is triggered if communication object *Safety Priority x* receives a telegram with the value 1 . The following parameter appears:

# ABB i-bus<sup>®</sup> KNX Commissioning

## Control period in seconds [0...65,535s, 0 = inactive]

Options: 0...65,535

This parameter defines the monitoring period of the *Safety Priority x* function. If during this time communication object *Safety Priority x\** receives a telegram with the triggering condition defined in parameter *Function Safety Priority x*, it will be triggered. Should the communication object *Safety Priority x\** receive a telegram that does not fulfill the trigger conditions, the control period is reset and restarted.

- 0: No monitoring is taking place. However, the *Safety Priority x* is triggered if communication object *Safety Priority x* receives a telegram with the triggering condition as defined in parameter *Function Safety Priority x*

\*x = 1, 2 or 3

### Please note

The monitoring period in the Switch Actuator should be at least twice as long as the cyclical transmission time of the sensor, so that the absence of an individual signal, e.g. due to a high bus load, does not immediately trigger an alarm.

## 3.2.2

### Parameter window A: General

#### Please note

This product manual describes all the current 2/4/8 and 12-fold Switch Actuators. These devices have 2/4/8 or 12 outputs respectively. However, as the functions for all outputs are identical, only the functions of output A will be described.

All general settings for output A are undertaken in this parameter window.

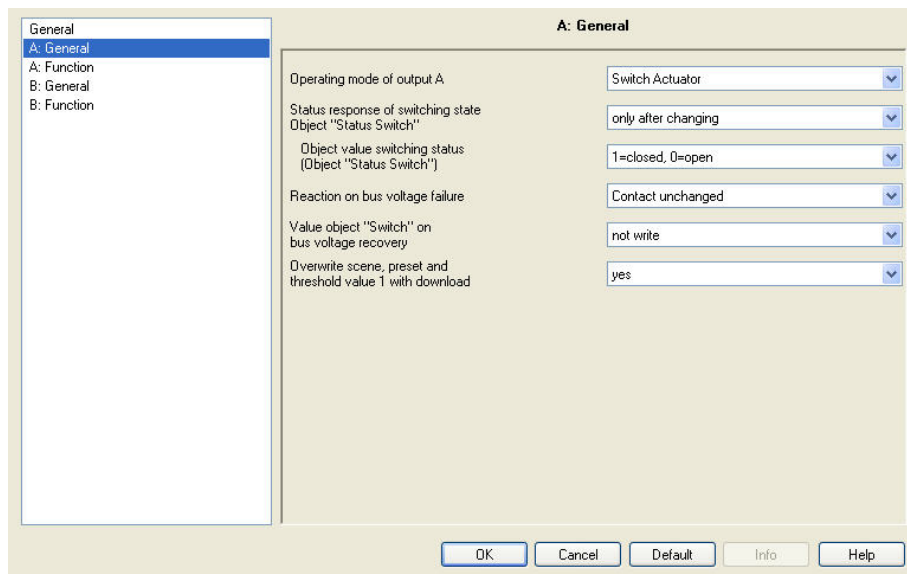

#### Operating mode of output A

Options: Switch Actuator  
Heating Actuator

This parameter defines the operating mode of the output. As the parameters and possible functions as well as other parameter windows are different for each operating mode, we will describe them separately here for each mode:

- [Operating mode Switch Actuator](#), p. 67
- [Operating mode Heating Actuator](#), from p. 119

## 3.2.3 Operating mode *Switch Actuator*

The *Switch Actuator* operating mode is used for normal switching, e.g. of lighting. The output is controlled via various logic, time and safety functions. The input signal for the function is received via communication object *Switch*. The *Switch Actuator* carries out the function independently and controls the corresponding relay.

The comprehensive range of additional functions available are described in this section.

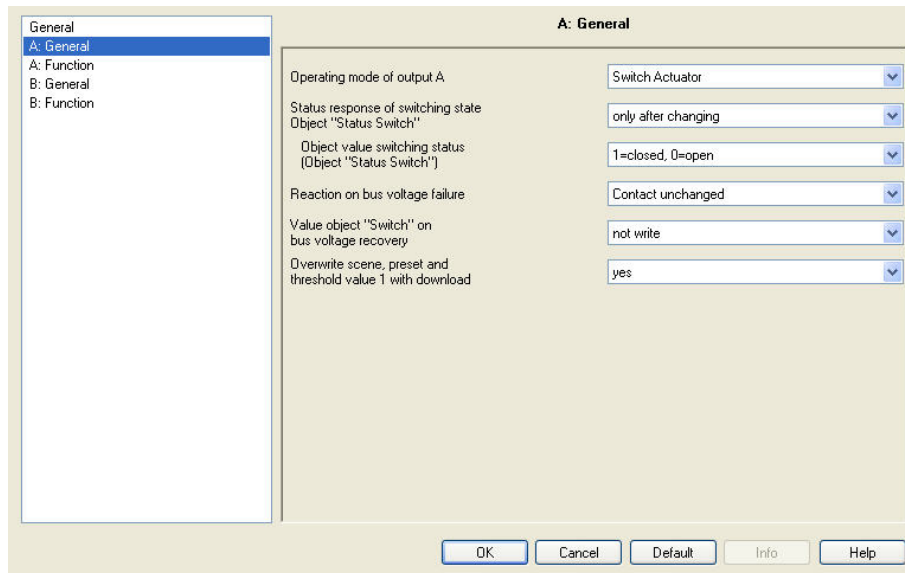

### Status response of switching state Object "Status Switch"

Options:   no  
          only after changing  
          always

This parameter can enable the communication object *Status Switch*. This contains the current switch state i.e. contact position.

- *no*: The contact position is updated but the status is not actively sent via the bus.
- *only after changing*: if the contact position changes the status is actively sent via the bus by communication object *Status Switch*.

- *always*: The status of the contact position is always actively sent via the bus via communication object *Status Switch*, even when a change in status has not occurred. Transmission is triggered as soon as the communication objects *Switch*, *Threshold input* or *Permanent ON* receive a telegram. Even a scene or a preset recall triggers transmission of the switch state. The status is also sent if logic objects *Logical connection 1* or *Logical connection 2* receive a telegram. However, status is not repeated or resent due to a safety change (forced operation, priority) and this applies to all types. This can have a major effect on the bus load on a Switch Actuator with multiple outputs.

#### Please note

After parameterization changes or subsequently switching off the status object, the existing assignment of group addresses to the *Switch* communication object is lost and needs to be re-allocated.

The status value to be sent is defined using the parameter *Object value switching status* (Object "Status Switch").

#### Please note

The contact position is determined by a sequence of priorities and logical connections – see [Function diagram](#), p. 161.

The contact position can only be correctly evaluated if the switching actions occur via KNX. The SA/S cannot differentiate between manual switching and a cable break or device fault.

#### Object value switching status (Object "Status Switch")

Options:     1=closed, 0=open  
              0=closed, 1=open

- *1=closed, 0=open*: In communication object *Status Switch*, the value 1 is written for a closed contact, and the value 0 for an open contact.
- *0=closed, 1=open*: In communication object *Status Switch* the value 0 is written for a closed contact, and the value 1 for an open contact.

#### Reaction on bus voltage failure

Options:     Contact open  
              Contact closed  
              Contact unchanged

The output can adopt a defined state on bus voltage failure with this parameter.

For further information see: [Reaction on bus voltage failure, recovery and download](#), p. 166

# ABB i-bus<sup>®</sup> KNX Commissioning

## Value object "Switch" on bus voltage recovery

Options:     not write  
              to write with 0  
              to write with 1

With this parameter, the output can be influenced after bus voltage recovery. As standard the communication object *Switch* receives the value 0.

- *not write*: After bus voltage recovery, communication object *Switch* retains the value 0. The contact position is not re-determined.

### Please note

Before the very first download (device fresh from the factory), the value before bus voltage failure is not defined. For this reason, the communication object *Switch* is written with 0 and the contact is open. If opening of the contact at bus voltage recovery before the first download (installation phase) is not desired, this can be prevented by temporarily removing the KNX voltage.

- *to write with 0*: The communication object *Switch* is written with a 0 on bus voltage recovery. The contact position is redefined and set based on the set device parameterization.
- *to write with 1*: The communication object *Switch* is written with a 1 on bus voltage recovery. The contact position is redefined and set based on the set device parameterization.

### Please note

Provided that no manual switching action has occurred, the communication object *Status Switch* indicates the correct status of the contact position independently of the value of communication object *Switch*.

The Switch Actuator draws the energy for switching the contact from the bus. Depending on the type of Switch Actuator, about 10 to 30 seconds is required after bus voltage is applied before sufficient energy is available to switch all contacts simultaneously, see [Technical data](#) from p. 9.

Depending on the set delay time in the parameter *Transmission and switching delay after recovery of bus voltage* in the *General* parameter window, the individual outputs assume the desired contact position only after this delay has elapsed. If a shorter delay time is set, the Switch Actuator will only switch the first contact when sufficient energy is stored in the Switch Actuator to immediately bring all outputs safely to the required position should another bus voltage failure occur.

## Overwrite scene, preset and threshold value 1 with download

Options:     no  
              yes

This parameter determines whether the preset and scene values and threshold value 1 of the output modified via the bus are overwritten in the Switch Actuator by the values set in parameter windows *A: Scene*, *A: Preset* or *A: Threshold*.

- *yes*: The values set in Parameter windows *A: Scene*, *A: Preset* or *A: Threshold* are transferred to the Switch Actuator when a download occurs, overwriting the existing values. Reprogramming of these values via the bus is still possible at any time.
- *no*: The values set in Parameter windows *A: Scene*, *A: Preset* or *A: Threshold value* are not transferred to the Switch Actuator when a download occurs. The values can only be changed and set via the bus.

For further information see: [Parameter window A: Scene](#), p. 89 , [Parameter window A: Preset](#), p. 86 and [Parameter window A: Threshold](#), p. 98



## 3.2.3.1

### Parameter window A: Function

In this parameter window you determine the response (reaction) of the output and can enable different functions, which makes further parameter windows available.

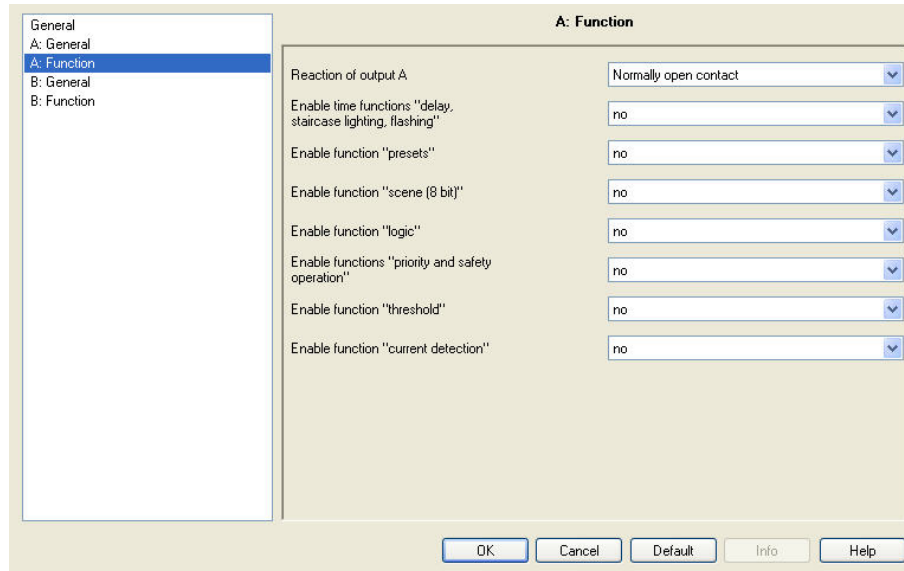

#### Reaction of output A

Options: Normally closed contact  
Normally open contact

This parameter determines the reaction of the output as a normally open or normally closed contact.

- *Normally closed contact*: An ON telegram (1) opens the contact and an OFF telegram (0) closes it.
- *Normally open contact*: An ON telegram (1) closes the contact and an OFF telegram (0) opens it.

#### Enable time functions "delay, staircase lighting, flashing"

Options: no  
yes

- *no*: Parameter window A: *Time* is not enabled for output A.
- *yes*: Parameter window A: *Time* for output A, and communication object *Disable time function*, are enabled.

Using this communication object, the Time function can be enabled (telegram with value 0) or disabled (telegram with value 1) via the bus.

As long as the Time function is disabled, the output can be switched on and off only without delay via the communication object *Switch*. The priorities as listed in [Function diagram](#) on p. 147 still remain valid.

## Please note

The Time function is only disabled when the ongoing Time function has ended.

While the output is disabled, the higher switching priorities, e.g. Safety functions, are undertaken.

Enabling the Time function enables the communication object *Permanent ON*. The output is switched on via this communication object. It remains switched on until communication object *Permanent ON* receives a telegram with the value 0.

Functions continue to operate in the background during the Permanent ON phase. The contact position at the end of the Permanent ON phase results from the functions operating in the background.

With the selection *yes* a new parameter appears:

### Value object "Disable time function" after bus voltage recovery

Options: "1", disable time functions  
"0", enable time functions

- "1", *disable time functions*: The Time function is disabled by a telegram with the value 1.

## Please note

They can only be re-enabled via the communication object *Disable time function*.

- "0" *enable time functions*: The Time function is enabled by a telegram with the value 0.

## Please note

Should the staircase light on the SA/S x.6.1.1, SA/S x.10.2.1 or SA/S x.16.2.1 be disabled while the Time function is running, the time sequence stops and the light remains ON until switched off by an OFF telegram.

On the SA/S x.16.6.1 the timing continues to the end. Only then is the Time function no longer active.

## How does the staircase lighting react on bus voltage failure?

Reaction in the event of bus voltage failure is specified by the parameter *Reaction on bus voltage failure* in parameter window A: *General*.

## How does the staircase lighting react on bus voltage recovery?

Reaction on bus voltage recovery is defined by two conditions:

- A By the communication object *Disable time function*. If staircase lighting is disabled after bus voltage recovery, it can only be switched on or off via the communication object *Switch*.
- B By parameterization of the communication object *Switch*. Whether the light is switched on or off on bus voltage recovery depends on the settings of *Switch*.

## Enable function "presets"

Options:     no  
              yes

- *no*: Parameter window A: *Preset* is not enabled for output A.
- *yes*: Parameter window A: *Preset* is enabled for output A.

## Enable function "scene (8 bit)"

Options:     no  
              yes

- *no*: Parameter window A: *Scene* is not enabled for output A.
- *yes*: Parameter window A: *Scene* is enabled for output A.

## Enable function "logic"

Options:     no  
              yes

- *no*: Parameter window A: *Logic* is not enabled for output A.
- *yes*: Parameter window A: *Logic* is enabled for output A.

## Enable functions "priority and safety operation"

Options: no  
yes

- *no*: Parameter window A: *Safety* is not enabled for output A.
- *yes*: Parameter window A: *Safety* is enabled for output A. This parameter window is used for parameterizing Safety Priorities 1, 2, 3 and Forced operation.

## Enable function "threshold"

Options: no  
yes

- *no*: Parameter window A: *Threshold* is not enabled for output A.
- *yes*: Parameter window A: *Threshold* is enabled for output A.

## Enable function "current detection"

Options: no  
yes

- *no*: Parameter window A: *Current Detection* is not enabled for output A.
- *yes*: Parameter window A: *Current detection*, and communication object *Contact monitoring*, are enabled for output A.

### Please note

These parameters and their functions are only visible for Switch Actuators with current detection. The actuators with integrated current detection are recognizable by a number 6 as the third number of the type designation, e.g. SA/S 2.16.6.1.

# ABB i-bus<sup>®</sup> KNX Commissioning

## Send status via object "contact monitoring"

Options:     no  
              only after changing  
              always

The send behavior of the communication object *Contact monitoring* can be set using this parameter. The *Contact monitoring* communication object displays contact faults. An error (value 1) is displayed as soon as a current of about 30 mA (observe the tolerances) is detected on an open contact.

- *no*: The value of the communication object is always updated but not sent.
- *always*: The switch status is updated and always sent when there is a change of status or the contact is to be opened and is not yet open. No value is sent when closing the contact. The reset status is only sent when it is next opened.
- *only after changing*: A telegram is only sent if the value of communication object *Contact monitoring* changes. This can influence the bus load significantly, particularly for Switch Actuators with multiple outputs.

### Important

The contact position can only be correctly evaluated if the switching actions occur via KNX.  
The SA/S cannot differentiate between manual switching and a cable break or device fault.  
Evaluation of the contact monitoring occurs about two seconds after opening the contact.

## 3.2.3.1.1 Parameter window A: Time

All settings for the *Time* function are undertaken in this parameter window: *ON/OFF delay*, *Staircase lighting function* and *Flashing*.

This parameter window is visible if the *Enable time function* parameter has been enabled in [Parameter window A: Function](#), p. 71.

Parameter	Value
Time function	Staircase lighting function
Duration of staircase lighting Minutes (0...1000)	5
Seconds (0...59)	0
Extending staircase lighting by multiple operation ('pumping up')	yes (retriggerable)
Staircase lighting can be switched off	ON with '1' and OFF with '0'
Warning before end of staircase lighting	via object
Warning time in sec. (0...65.535) add to duration of staircase lighting	45
Duration of staircase lighting can be changed by object	no
Restart of staircase time after end of permanent ON	no

Explanations of the Time functions and sequences can be found in [Planning and application](#), p. 141. Please also refer to the [Function diagram](#), p. 147, from which the switching and timing priorities originate.

# ABB i-bus<sup>®</sup> KNX Commissioning

## Time function

Options:     [Staircase lighting function](#)  
              ON/OFF delay  
              Flashing

This parameter defines the type of *Time* function for each output.

- *Staircase lighting function*: The value that switches the staircase lighting on and off can be parameterized. The staircase lighting time starts when the function is switched on. It is switched off immediately after the staircase lighting time ends.

### Please note

Switch on means the closing of a normally open contact or opening of a normally closed contact. The staircase lighting function can also be recalled via communication object *Switch*, *Logical Connection x* ( $x = 1, 2$ ) or via a light scene recall. The staircase lighting function can be disabled by a telegram to the communication object *Disable time function*. Parameterization is undertaken in parameter window [Parameter window A: Function](#), p. 71, with the parameter *Value object "Disable time function" on bus voltage recovery*.

- *ON/OFF delay*: The output can be switched on or off with a delay via this function.
- *Flashing*: The output starts to flash as soon as communication object *Switch* receives the parameterized value. The flashing period can be adjusted via the duration set for ON or OFF. At the start of the flashing period, the output is switched on with a normally open contact and off with a normally closed contact. When communication object *Switch* receives a new value, the flashing period will restart. Relay state is parameterizable after flashing. Flashing can be inverted when the output is used as a normally closed contact. The communication object *Status Switch* indicates the current relay state during flashing.

### Please note

The *Flashing* function can be disabled by a telegram to communication object *Disable time function*. Parameterization is undertaken in parameter window [Parameter window A: Function](#), p. 71, with the parameter *Value object "Disable time function" on bus voltage recovery*.

The following parameters appear when Staircase lighting is selected:

## **Duration of staircase lighting**

### **Minutes**

Options: 0...5...1,000

### **Seconds**

Options: 0...59

The staircase lighting time defines how long the staircase lighting is switched on after an ON telegram. The input is made in minutes and seconds. The staircase lighting time may extend depending on the value set in the parameter *Warning before end of staircase lighting*.

## **Extending staircase lighting by multiple operation ("pumping up")**

Options: no (not retriggerable)  
yes (retriggerable)  
up to max. 2 x staircase lighting time  
up to max. 3 x staircase lighting time  
up to max. 4 x staircase lighting time  
up to max. 5 x staircase lighting time

If a further ON telegram is received during the staircase lighting time sequence, the remaining staircase lighting time can be extended by a further period. This is possible by repeated operation of the button ("pumping up") until the maximum parameterized number of retriggering operations is reached. The maximum time can be set to 1, 2, 3, 4 or 5 times the staircase lighting time.

Let's say the staircase lighting time has been extended by "pumping up" to the maximum time. If some of the time has already timed out, the staircase lighting time can be re-extended to the maximum time by "pumping up".

However the parameterized maximum time may not be exceeded.

- *no (not retriggerable)*: The receipt of an ON telegram is ignored. The staircase lighting time continues without modification to completion.
- *yes (retriggerable)*: New ON telegrams reset the staircase lighting time and starts to count again. This process can be repeated as often as desired using this selection.
- *up to max. 2/3/4/5 x staircase lighting time*: New ON telegrams extend the staircase lighting time by 2/3/4/5 times the staircase lighting time.



## Staircase lighting can be switched off

Options: ON with "1" and OFF with "0"  
ON with "1" no action with "0"  
ON with "0" or "1", switch OFF not possible

This parameter defines the telegram value used for switching the staircase lighting on and off prematurely.

- *ON with "0" or "1" switch OFF not possible*: The staircase lighting function is switched on independently of the value of the incoming telegram. Premature switch off is not possible.

### Please note

After enabling the Time function via communication object *Disable time function*, the contact position of the enabled output remains unchanged. The Time function is only triggered after the next switching telegram. However this means that if set to the option *ON with "1" no action with "0"*, the output is simultaneously switched on when enabled. Switch off via the bus is thus not possible. Only after e.g. the staircase lighting function is started does the output switch off, after the staircase lighting time has elapsed.

## Warning before end of staircase lighting

Options: no  
via object  
via quick switching OFF/ON  
via object and switching OFF/ON

Before the staircase lighting time elapse, the user can be informed of the imminent lighting switch of by a warning. If the warning time is not 0, the staircase lighting time is extended by the warning time. The warning time is not modified by "pumping up".

- *no*: No warning is given, the staircase lighting switches off immediately after the staircase lighting time elapses. If the staircase lighting is ended prematurely, e.g. by a switching telegram, no warning is given.

## There are two types of warning:

1. The communication object *warning stair lighting* is set to the value 1 when the warning time starts, and remains until it has elapsed. The communication object can be used, for example, to switch a warning light.
2. Switching the output (briefly OFF and ON again).

Both options can be used together or separately. The time duration between the OFF and ON process is about 1 second. If the warning time is not 0, the staircase lighting time is extended by the warning time.

### Please note

When dealing with the warning time it is important to remember that the SA/S draws its switching energy exclusively from the KNX. Furthermore, the SA/S collects enough energy before the first switch to ensure that all outputs can safely go to the required position should the bus voltage fail. Under these conditions, only a certain number of switching actions are possible per minute:  
see [Technical data](#), from p. 9.

### Warning time in sec. [0...65,535] add to duration of staircase lighting

Options: 0...45...65,535

This parameter is visible if you have set a warning before the staircase lighting time ends. The warning time must be entered in seconds. The staircase lighting time is extended by the warning time. The warning is triggered at the start of the warning time.

The warning time is not modified by “pumping up”.

### Duration of staircase lighting can be changed by object “Staircase lighting time”

Options: no  
yes

- *yes*: A 2 byte *Duration of stair lighting* communication object is enabled. This can be used to change the staircase lighting time via the bus. The value defines the staircase lighting time in seconds. The staircase lighting function that has already started is completed first. A change is applied to the staircase lighting time next time it is recalled.
- *no*: The staircase lighting time cannot be changed via the bus.

### Please note

On bus voltage failure, the staircase lighting time changed via the bus is lost and must be reset. Until a new value is set, the staircase lighting time set via ETS applies.

## How does the staircase lighting react on bus voltage failure?

Reaction in the event of bus voltage failure is specified by the parameter *Reaction on bus voltage failure* in parameter window *A: General*.

## How does the staircase lighting react on bus voltage recovery?

Reaction on bus voltage recovery is defined by two conditions.

- A By the communication object *Disable time function*. If staircase lighting is disabled after bus voltage recovery, it can only be switched on or off via the communication object *Switch*.
- B By the parameterization of the communication object *Switch*. Whether the light is switched on or off on bus voltage recovery depends on the settings of *Switch*.

## Restart of staircase time after end of permanent ON

Options:     no  
              yes

- *no*: The lighting switches off if *Permanent ON* is ended.
- *yes*: The lighting remains on and the staircase lighting time restarts.

The function of Permanent ON is controlled via the communication object value *Permanent ON*. If the communication object receives a telegram with the value 1, the output is switched on regardless of the value of the communication object *Switch* and remains switched on until the communication object *Permanent ON* has the value 0.

### Please note

*Permanent ON* only switches ON and “masks” the other functions. This means that the other functions, e.g. Staircase lighting time or “Pumping up”, continue to run in the background but do not initiate any action. After *Permanent ON* ends, the contact position which would result without the *permanent ON* function becomes active.

The following parameters appear with *ON/OFF delay*:

The screenshot shows a software window titled "A: Time". On the left is a tree view with the following items: "General", "A: General", "A: Function", "A: Time" (highlighted), "B: General", and "B: Function". The main area of the window contains the following parameters:

Parameter	Value
Time function	ON/OFF delay
Delay for switching on: (Min. [0...65535])	0
Delay for switching on: Sec. [0...59]	0
Delay for switching OFF: Min. [0...65,53]	0
Delay for switching OFF: Sec. [0...59]	0

At the bottom of the window are buttons for "OK", "Cancel", "Default", "Info", and "Help".

The output can be switched on or off with a delay via this function. Explanations for ON/OFF delay can be found at [ON/OFF delay](#), p. 151. You will also find a timing diagram as well as explanations on the effect of various ON and OFF telegrams in combination with ON/OFF delay.

**Delay for switching on: Min. [0...65,535]**

**Delay for switching on: Sec. [0...59]**

Options:     0...65,535  
              0...59

Here you set the time by which an ON telegram is delayed after switch on.

**Delay for switching OFF: Min. [0...65,535]**

**Delay for switching OFF: Sec.. [0...59]**

Options:     0...65,535  
              0...59

Here, you set the amount of time by which switch OFF is delayed after a switch OFF telegram.

The following parameters appear when *Flashing* is selected:

The screenshot shows a software window titled "A: Time". On the left is a tree view with the following items: General, A: General, A: Function, A: Time (highlighted), B: General, and B: Function. The main area contains the following parameters:

Parameter	Value
Time function	Flashing
Flashing if object "Switching" is	always flashing, ON (1) or OFF (0)
Time for ON: Min. (0..65.535)	0
Time for ON: Sec. (1..59)	5
Time for OFF: Min. (0..65.535)	0
Time for OFF: Sec. (1..59)	5
Number of ON-impulses: (1..100)	5
Contact position after flashing	calculate present contact position
Note: Observe contact life and switching frequency per minute	see technical data

At the bottom of the window are buttons for OK, Cancel, Default, Info, and Help.

The output starts to flash as soon as communication object *Switch* receives the parameterized value. The flashing period can be adjusted via the parameterized time duration for ON or OFF. At the start of the flashing period, the output is switched on with a normally open contact and off with a normally closed contact. When communication object *Switch* receives a new value, the flashing period will restart. The relay state after flashing can be parameterized. Flashing can be inverted when the output is used as a normally closed contact.

The communication object *Status Switch* indicates the current relay state during flashing.

#### Please note

Only a certain number of switching actions are possible per minute and Switch Actuator. This means that frequent switching may cause a switching delay, see [Technical data](#), from p. 9. The same applies directly after bus voltage recovery.

When the flashing function is selected, the service life of the switching contacts must be considered, see [Technical data](#), from p. 9.

The Flashing function can be disabled by a telegram to the communication object *Disable time function*. The parameterization is undertaken in parameter window [Parameter window A: Function](#), p. 71, with the parameter *Value object "Disable time function" on bus voltage recovery*.

## Flashing if object "Switching" is

Options:      ON (1)  
                 OFF (0)  
                 always flashing, ON (1) or OFF (0)

Here you set the value of the communication object *Switch* at which the output flashes. Flashing is not retriggerable.

- *ON (1)*: Flashing starts when communication object *Switch* receives a telegram with the value 1. A telegram with the value 0 ends flashing.
- *OFF (0)*: Flashing starts when communication object *Switch* receives a telegram with the value 0. A telegram with the value 1 ends flashing.
- *always flashing, ON (1) or OFF (0)*: A telegram with the value 1 or 0 triggers flashing. Suspension of flashing is not possible in this case.

**Time for ON: Min. [0...65,535]**

**Time for ON: Sec. [0...59]**

Options:      0...65,535  
                 1...5...59

Time for ON defines how long the output is switched on during a flashing period. The smallest value is 1 second.

### Please note

Only a certain number of switching actions are possible per minute and Switch Actuator. This means that frequent switching may cause a switching delay, see [Technical data](#), from p. 9. The same applies directly after bus voltage recovery.

**Time for OFF: Min. [0...65,535]**

**Time for OFF: Sec. [0...59]**

Options:      0...65,535  
                 1...5...59

The time for OFF defines how long the output is switched off during a flashing period. The smallest value is 1 second.

### Please note

Only a certain number of switching actions are possible per minute and Switch Actuator. This means that frequent switching may cause a switching delay, see [Technical data](#), from p. 9. The same applies directly after bus voltage recovery.

# ABB i-bus<sup>®</sup> KNX Commissioning

## Number of ON impulses: [1...100]

Options: 1...5...100

This parameter defines the maximum number of pulses. This is useful to prevent flashing causing unnecessary wear of the contacts.

## Contact position after flashing

This parameter defines the state that the parameter should assume after flashing.

- *ON*: The output is switched on after flashing.
- *OFF*: The output is switched off after flashing.
- *calculate present contact position*: The output assumes the contact position which it had before flashing commenced.

For further information see: [Function diagram](#), p. 147

<b>Please note</b>
Observe the contact life span and switching cycles per minute.

<b>Please note</b>
Only a certain number of switching actions are possible per minute and Switch Actuator. This means that frequent switching may cause a switching delay, see <a href="#">Technical data</a> , from p. 9. The same applies directly after bus voltage recovery.

## 3.2.3.1.2 Parameter window A: Preset

Preset settings can be made in this parameter window.

This parameter window is visible if *Enable function "presets"* has been enabled in [Parameter window A: Function](#), p. 71.

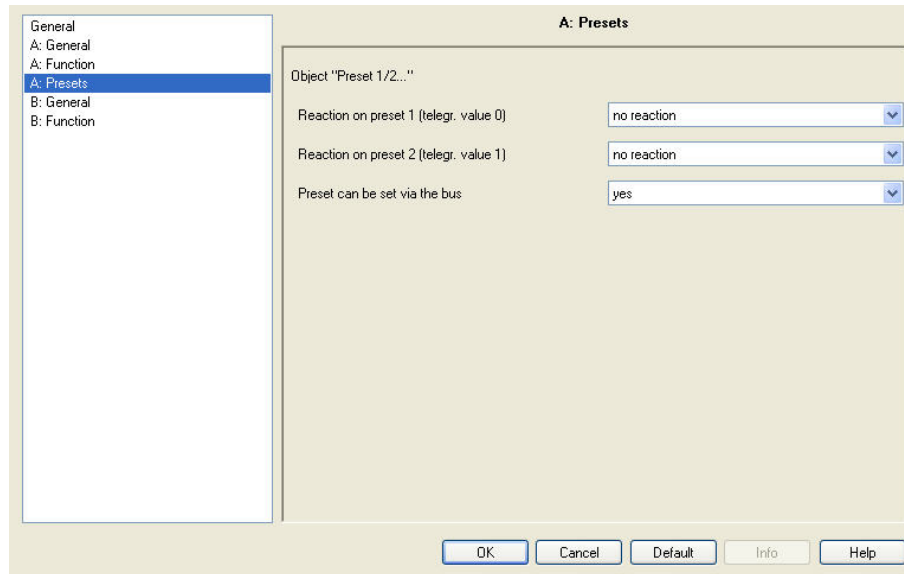

### What is a preset?

Presets are used to recall a parameterized switch value, e.g. in order to implement light scenes. In addition, the output value that is currently set can be saved as a new preset value.

The preset values can be set (stored) via the bus. In parameter window A: *General* you define whether the values set in ETS are transferred to the Switch Actuator with a download. This is how the values saved in the actuator are overwritten.

Two presets are available per output. Preset 1 is recalled by a telegram with the value 1, Preset 2 is recalled by a telegram with the value 0. Separate communication objects are available for recalling and for saving/setting a preset.

Preset telegrams continue to be executed when the Staircase lighting function is set. The Staircase lighting function is triggered by a preset recall (ON telegram).



## Reaction on preset 1 (telegr. value 0)

Options:     no reaction  
              ON  
              OFF  
              restore old value before preset 2  
              restore parameterized value of preset 2

This parameter determines the contact position that the output assumes when preset 1 is recalled, i.e., communication object *Call Preset 1/2* receives a telegram with the value 0.

The following functions can be selected as further selection options:

- *no reaction*: No switching action is undertaken with a preset recall. The preset is ignored. The preset is also ignored on storage via the bus, i.e., no value is saved, the preset remains inactive.
- *restore old value before preset 2*: The current relay contact position is stored when preset 2 is first recalled. This stored value (switch state) is retained until it is set again by the recall of preset 1. The current contact position is stored again next time preset 2 is recalled.

### Example

With preset 2, the lighting in a conference room is recalled for a presentation. When the presentation is finished, the lighting is restored via preset 1 to the state it was in previously.

- *restore parameterized value of preset 2*: resets preset 2 to the parameterized value. This can be advisable if preset 2 can be stored via the bus, see below.

### Please note

With options *restore old value before preset 2* or *restore parameterized value of preset 2*, saving the preset concerned has no effect. The saved value is not recalled, but rather the parameterized function is undertaken.

## Reaction on preset 2 (tegr. value 1)

Options:     no reaction  
              ON  
              OFF

This parameter determines the contact position that the output assumes when preset 2 is recalled, i.e., communication object *Recall Preset 1/2* receives a telegram with the value 1.

At the same time, on the first call up of preset 2, the state of the output is saved so that the value before preset 2 can be restored if the setting is changed accordingly.

## Preset can be set via the bus

Options:     no  
              yes

This parameter enables the communication object *Set preset 1/2*. It is thus possible to store the current contact position as the new preset value.

Telegram value 0 saves preset 1, whereas telegram value 1 saves preset 2.

If the option *no reaction, restore old value before preset 2* or *restore parameterized value of preset 2* has been selected in parameter *Reaction on preset 1 (tegr. value 0)*, no new communication object value is saved.

Using the parameter *Overwrite scene, preset and threshold value 1 with download* in parameter window A: *General*, it is possible not to overwrite the scene values set via the bus during a download and thus to protect them.

If a mains voltage failure occurs the stored preset values are lost. They are overwritten by the parameterized default values.

### 3.2.3.1.3

#### Parameter window A: Scene

All settings for the *Scene* function are undertaken in this parameter window.

This parameter window is visible if the parameter *Enable function "scene"* has been enabled in [Parameter window A: Function](#), p. 71.

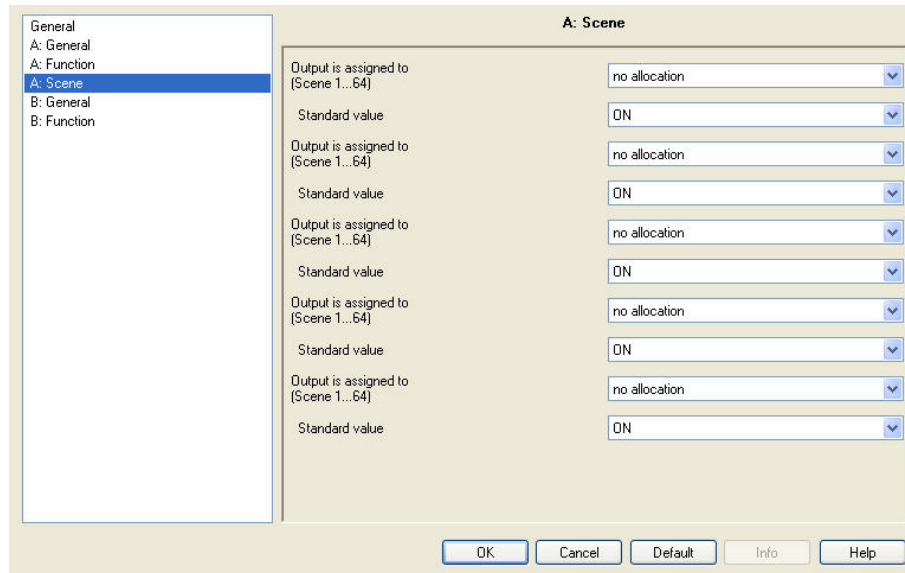

Using the parameter *Overwrite scene, preset and threshold value 1 with download* in parameter window A: *General*, it is possible not to overwrite the scene values set via the bus during a download and thus to protect them.

#### Output is assigned to [Scene 1...64]

Options:     no allocation  
              Scene 1  
              ...  
              Scene 64

The Scene function manages up to 64 scenes using one single group address. With this group address, all slaves integrated into a scene are linked via a 1 byte communication object. The following information is contained in a telegram:

- Scene number (1...64) and
- Telegram: *Recall scene or store scene*.

The output can be integrated in up to five scenes. So for example, the output can be switched on by a scene in the morning and switched off in the evening, or it can be integrated into light scenes.

# ABB i-bus<sup>®</sup> KNX Commissioning

## Standard value

Options: ON  
OFF

By storing a scene, the user has the opportunity to change the parameterized value stored in ETS. After a bus voltage failure, the value saved via KNX is retained.

### Please note

When a scene is recalled:

- the *Time* function is restarted.
- the *logical connections* are re-evaluated.

For further information see: [Communication objects, Output A](#), p. 111, [Scene function](#), p. 156 and [Code table, 8 bit scene](#) p. 171

## 3.2.3.1.4 Parameter window A: Logic

All settings for the *Logic* function are undertaken in this parameter window.

This parameter window is visible if *Enable function "logic"* has been enabled in [Parameter window A: Function](#), p. 71.

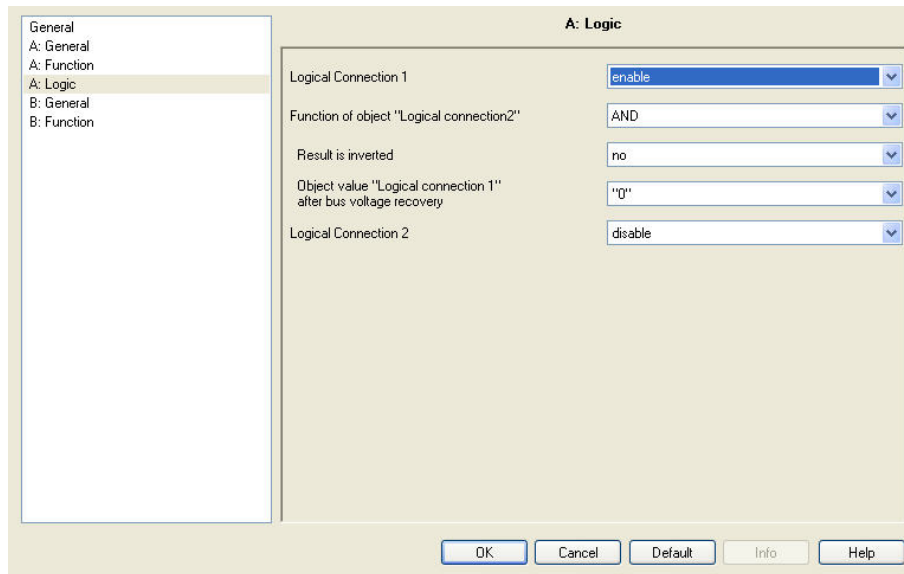

The *Logic* function provides up to two logic objects for each output, which can be logically connected via the communication object *Switch*.

The logic is always re-calculated when an object value is received. First, the communication object *Logical connection 1* is evaluated with communication object *Switch*. The result is then logically linked with communication object *Logical connection 2*.

Explanations of the Logic function can be found in [Logic function](#), p. 153. Please also observe the [Function diagram](#), p. 147, where the priorities become evident.

### Logical Connection 1

Options:     disable  
              enable

These parameters enable the communication object *Logical connection 1*.

- *enable*: The following parameters appear:

## Function of object "Logical Connection 1"

Options:     AND  
              OR  
              XOR  
              GATE

The logical function of the communication object *Logical Connection 1* is determined with the switch telegram.

All three standard operations (AND, OR, XOR) are possible. In addition, the GATE operation can be used to inhibit switch commands.

For further information see: [Logic function](#), p. 153

## Result is inverted

Options:     no  
              yes

- *yes*: The result of the logical connection can be inverted.
- *no*: There is no inversion.

## Object value "Logical connection 1" after bus voltage recovery

Options:     1  
              0

This parameter defines the value allocated to the communication object *Logical connection 1* on bus voltage recovery.

### Please note

The values of communication objects *Logical connection 1/2* are stored on bus voltage failure. The values are set again on bus voltage recovery. On reset via the bus, the values of communication objects *Logical Connection 1/2* remain unchanged.

If GATE is selected with the parameter *Function of logical connection*, a further parameter appears:

# ABB i-bus<sup>®</sup> KNX Commissioning

## Gate disabled, if Object value "Logical Connection 1" is

Options:     1  
              0

This parameter defines the value at which communication object *Logical Connection 1* disables the GATE.

While it is disabled, telegrams received on communication object *Switch* are ignored. As long as GATE is active, the last value sent to the GATE input remains on the output's logic gate. When disabled, the value that was on the output beforehand remains.

After the GATE is enabled, this value will be retained until a new value is received.

For further information see: [Function diagram](#), p. 147

The GATE is deactivated on bus voltage failure and remains so on bus voltage recovery.

## Logical Connection 2

The same programming options exist as those for parameter *Logical Connection 1*.

## 3.2.3.1.5 Parameter window A: Safety

All settings for the *Safety* function are undertaken in this parameter window.

This parameter window is visible if the parameter *Enable functions "priority and safety operation"* has been enabled in [Parameter window A: Function](#), p. 71

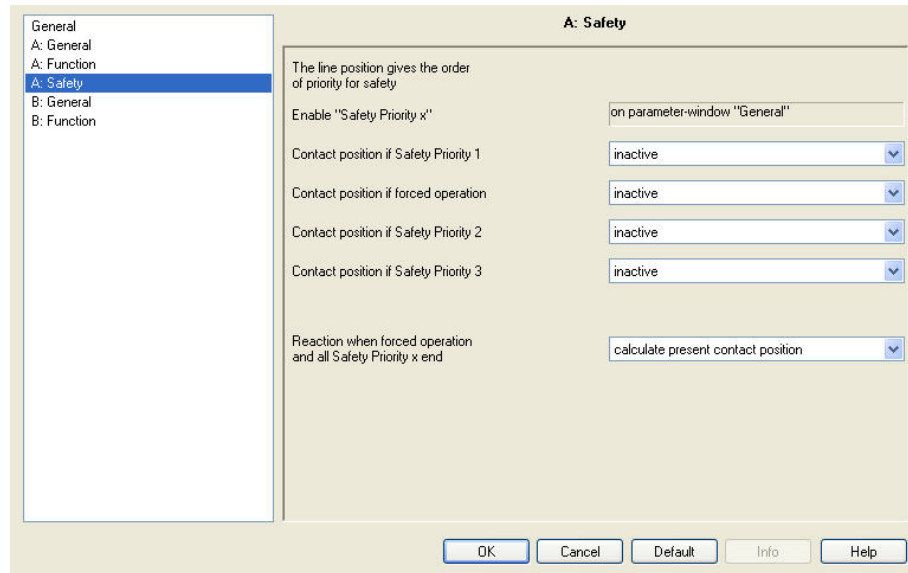

The forced operation (a 1 or 2 bit communication object per output) or safety priority (three independent 1 bit communication objects per Switch Actuator) sets the output in a defined state which can no longer be changed as long as forced operation or safety priority is active. The parameterized reaction on bus voltage failure and recovery has a higher priority.

Enabling of the three communication objects *Safety Priority x* ( $x = 1, 2, 3$ ) is undertaken in the *General* parameter window. Monitoring time and the telegram value to be monitored are set in this window. If a telegram is not received within this monitoring time, the output will assume the safety position. This is determined in parameter window *A: Safety*, described below.

In contrast to the three safety priorities, each output has a communication object *Forced operation*.

Forced operation can be activated or deactivated via a 1 or 2 bit communication object. Using the 2 bit communication object, the output state is defined directly via the value.

The contact position after the safety function ends can be set using the parameter *Reaction when forced operation and all Safety Priority x end*.



# ABB i-bus<sup>®</sup> KNX Commissioning

If multiple demands occur, the priority is defined as follows in accordance with the sequence in parameter window A: *Safety*:

- Safety Priority 1 (highest priority)
- Forced operation
- Safety Priority 2
- Safety Priority 3 (lowest priority)

With the option *inactive*, Safety Priority x or Forced operation and the associated communication object are not considered and are omitted from the priority sequence.

## Contact position if Safety Priority 1

Options:      unchanged  
                 inactive  
                 ON  
                 OFF

This parameter determines the contact position of the output if the safety condition *Safety Priority 1* (setting undertaken in parameter window [Parameter window General](#), p. 62) has been met.

The 1 bit communication object *Safety Priority 1* is used as a master for the safety position. The contact positions ON, OFF and unchanged are available.

- *inactive*: The state of communication object *Safety Priority 1* has no effect on the output.

## Contact position if forced operation

Options:      inactive  
                 unchanged via 1 bit object  
                 on, via 1 bit object  
                 off, via 1 bit object  
                 switch position via 2 bit object

Forced operation relates to the 1 or 2 bit *Forced operation* communication object available on every output.

- *inactive*: The state of the communication object *Forced operation* has no effect on the output.
- *unchanged (via 1 bit object), on (via 1 bit object) and off (via 1 bit object)*: The 1 bit communication object *Forced operation* determines the contact position of the output during forced operation.
- *Switch position via 2 bit object*: The 2 bit *Forced operation* communication object is enabled. The value of the telegram sent via the 2 bit object determines the contact position, see the following table:

Value	Bit 1	Bit 0	State	Description
0	0	0	Enabled	If the communication object <i>Forced operation</i> receives a telegram with the value 0 (binary 00) or 1 (binary 01), the output is enabled and can be actuated via different communication objects.
1	0	1	Enabled	
2	1	0	Forced OFF	If the communication object <i>Forced operation</i> receives a telegram with the value 2 (binary 10), the output of the Switch Actuator is switched off and remains disabled until forced operation is switched off again. Actuation via another communication object is not possible as long as forced operation is activated. The state of the output at the end of forced operation can be parameterized.
3	1	1	Forced ON	If the communication object <i>Forced operation</i> receives a telegram with the value 3 (binary 11), the output of the Switch Actuator is switched on and remains disabled until forced operation is switched off again. Actuation via another communication object is not possible as long as forced operation is activated. The state of the output at the end of forced operation can be parameterized.

### Object value "Forced positioning" on bus voltage recovery

This parameter is only visible if forced operation is activated.

Depending on whether the forced operation object is a 1 bit or 2 bit communication object, there are two different parameterization possibilities available:

1 bit communication object:

Options: inactive  
active

- *inactive*: Forced operation is switched off, and the output behaves in the same way as with parameter *Reaction when forced operation and all safety Priority x end*.
- *active*: Forced operation is active again after bus voltage recovery. The contact position of the output is determined by the parameterization of *Contact position if forced operation*.

# ABB i-bus<sup>®</sup> KNX Commissioning

2 bit communication object:

Options:     "0" inactive  
              "2" OFF  
              "3" ON

- *"0" inactive*: Forced operation is switched off and the output behaves in the same way as with parameter *Reaction when forced operation and all safety Priority x end*.
- *"2" OFF*: The communication object *Forced operation* is written with the value 2 and the output is switched off.
- *"3" ON*: The communication object *Forced operation* is written with the value 3 and the output is switched on.

## **Contact position if Safety Priority 2** **Contact position if Safety Priority 3**

The same setting options exist as those for parameter *Contact position if Safety Priority 1*.

## **Reaction when forced operation** **and all Safety Priority x end**

Options:     calculate present contact position  
              ON  
              OFF  
              unchanged

This parameter is only visible if forced operation or a Safety Priority x (x = 1, 2 or 3) function is activated.

The contact position of the relay at the end of forced operation and safety priorities is defined here.

- *calculate present contact position*: After forced operation has ended, the switch value is recalculated and immediately initiated, i.e., the output continues to operate normally in the background during forced operation, the output is not changed and is only set after safety priorities end.
- *unchanged*: The contact position is retained during forced operation or safety priority. The contact position only changes when a new calculated switch value is received.

## 3.2.3.1.6 Parameter window A: Threshold

All settings for the *Threshold* function are undertaken in this parameter window.

This parameter window is visible if the *Enable function threshold* parameter has been enabled in [Parameter window A: Function](#), p. 71.

Parameter	Value
Data type of object "Threshold input"	1 byte (0...255)
Change Threshold 1 over bus	no
Threshold value 1 (0...255)	80
Threshold value 2 (0...255)	160
Threshold values define hysteresis	yes
Behaviour	
Falling below lower threshold	no reaction
Exceeding upper threshold	no reaction
Object "threshold input" value on bus voltage recovery (0...255)	0

The threshold function facilitates the evaluation of a 1 or 2 byte communication object, *Threshold input*. A switching action can be triggered as soon as the value of the communication object undershoots or overshoots a threshold value. Two independent threshold values are available. Threshold 1 can be modified via the bus.

For further information see: [Threshold function](#), p. 159

When the threshold function is active, the Switch Actuator continues to receive switching telegrams. In this way, the contact position determined by the threshold function can be changed, see [Function diagram](#), p. 147. The threshold function generates a switching telegram as soon as a new threshold telegram is received and a new switching condition exists simultaneously due to undershoot or overshoot of the switching criterion.

### Data type of object "Threshold input"

Options:     1 byte [0...255]  
              2 byte [0...65,535]

The data type for the threshold input received via the communication object *Threshold input* can be determined here.

You can choose between a 1 byte integer value or a 2 byte counter value.

## Change Threshold 1 over bus

Options:     no  
              yes

This parameter defines whether threshold value 1 can or cannot be changed via the bus.

- **yes:** Communication object *Threshold value 1* can be changed via the bus. This can be a 1 or 2 byte communication object depending on the parameterization of the threshold value input.
- **no:** The communication object *Threshold value 1* cannot be changed via the bus.

With the parameter *Overwrite scene, preset and threshold value 1 with download* in parameter window A: *General*, it is possible during a download to not overwrite the threshold values set via the bus and thus to protect them.

## Threshold value 1 [0...255]

The value range is dependent on the selection made in the parameter *Data type of object "Threshold input"*.

1 byte [0...255]:

Options:     0...80...255

2 byte [0...65,535]:

Options:     0...20,000...65,535

## Threshold value 2 [0...255]

The value range is dependent on the selection made in the parameter *Data type of object "Threshold input"*.

1 byte [0...255]:

Options:     0...160...255

2 byte [0...65,535]:

Options:     0...40,000...65,535

## Threshold values define hysteresis

Options:     no  
              yes

This parameter defines whether Threshold values 1 and 2 should be interpreted as hysteresis limits.

The hysteresis can reduce continuous threshold value messages if the input value fluctuates around one of the threshold values.

For further information see: [Threshold function](#), p. 159

With option yes, the following parameters appear:

## Behaviour

### Falling below lower threshold

### Exceeding upper threshold

Options:     no reaction  
              ON  
              OFF

This parameter determines the contact position of the output based on the value of communication object *Threshold input* if this value exceeds or falls below the upper or lower threshold respectively.

A reaction only occurs if the communication object value was previously smaller or larger than Threshold 1 or Threshold 2.

For further information see: [Threshold function](#), p. 159

With option *no*, the following parameters appear:

### Object value < lower threshold

### Lower thrsh. <= object <= upper thrsh.

### Object value > lower threshold

Options:     unchanged  
              ON  
              OFF

This parameter determines the contact position of the output (ON, OFF, unchanged) based on the threshold (communication object) value.

## Object "threshold input" value on bus voltage recovery [0...255]

## Object "threshold input" value on bus voltage recovery [0...65,535]

The value range is dependent on the selection made in the parameter *Data type of object "Threshold input"*.

1 byte [0...255]:

Options:     0...255

2 byte [0...65,535]:

Options:     0...65,535

This parameter determines the value of communication object *Threshold input* after bus voltage recovery.

Threshold value evaluation is carried out after bus voltage recovery using the threshold parameterized here, whereby the last *Status Threshold value* detected in operation is used for comparison. Should no *Status Threshold value* exist before bus voltage failure, the factory-set status (hysteresis limit undershoot) is assumed.

## 3.2.3.1.7 Parameter window A: Current Detection

All settings for the *Current Detection* function are undertaken in this parameter window.

This parameter window is visible if the *Enable function "current detection"* parameter has been enabled in [Parameter window A: Function](#), p. 71.

### Please note

The current detection function and associated parameter window is only visible on Switch Actuators with current detection (SA/S x.16.6.1). It offers the same functionality in both Switch Actuator and Heating Actuator modes.

The screenshot shows the 'A: Current Detection' parameter window. On the left, a tree view lists the navigation structure: General, A: General, A: Function, A: Current Detection (highlighted), B: General, and B: Function. The main panel contains the following settings:

- Datapoint type object "Current Value" (0...65.535 in mA): 2 byte counter (DPT 7.012)
- Send current value, transmission time (0...65.535s, 0 = not send): 0
- Send current value on change of value: no
- Enable current threshold value(s): no
- Only for sinusoidal current the current value is the rms value: see technical data

At the bottom of the window are buttons for OK, Cancel, Default, Info, and Help.

The settings in parameter window *A: Current Detection* determine if and how the load current of the output is evaluated. Activating current detection enables the communication object *Current Value*.

Communication object *Current Value* transfers the detected current value as a mA value via KNX. The current value is a pure sine wave normalized to an RMS value.

For further information see: [Current detection specifications](#), p. 44 and [Current detection](#), p. 141

## Datapoint type object "Current Value" [0...65,535 in mA]

Options:      2 byte counter (DTP 7.012)  
                 4 byte float (DTP 14.019)

This parameter determines the data type (datapoint, DTP) of the communication object *Current Value*. A 2 byte counter (EIS 10, DPT 7.012, 1 mA per digit) or a 4 byte float value (EIS 9, DTP 14.019) can be selected.

### Please note

The current detection range is designed for currents between 20 mA and 20 A.

## Send current value, transmission time [0...65,535s; 0 = not send]

Options:      0  
                 1...65,535

This parameter determines if and at which intervals the present current value is sent via communication object *Current Value*. The cycle time must be entered in seconds.

- 0: No current values are sent cyclically via the bus. The present current values are however continuously available in the output's *Current Value* communication object, and can be read out.

## Send current value on change of value

Options:      no  
                 25/50/100/200/500 mA  
                 1/2/5 A

This parameter determines that on a load change the current value is sent via the bus via the *Current Value* communication object. A current value is always sent via the bus if the current change is greater than the current value set in this parameter. The current value sent via the bus applies as a new reference value.

- *no*: No current value is sent.

The smaller the current value set, the more precisely the sent value will correspond with the actual value. Highly fluctuating current values may result in a high bus load.

For further information see: [Current detection specifications](#), p. 44



# ABB i-bus<sup>®</sup> KNX Commissioning

If the parameter *Send current value, transmission time [0...65,535s, 0 = not send]* is also activated, the counter is reset and restarted after sending the current value.

## **Please note**

If for example, a current change of 1 A has been selected, a current value is only sent if the load current exceeds 1 A when starting, for example, from 0 A. This means that no current value is sent (displayed) when a current of 0.9 A is flowing.

The other way around, a current value can be displayed (sent) even though no current is flowing. Starting from 1.5 A the current is reduced to 0 A. A current value of 0.5 A is sent via the bus. Since no further 1 A current change can occur for a current value of 0, no new value is sent. The last value sent and displayed is 0.5 A.

These inaccuracies can be prevented by additional activation of the parameter *Send current value, transmission time [0...65,535s, 0 = not send]* or if a sufficiently small current change has been selected.

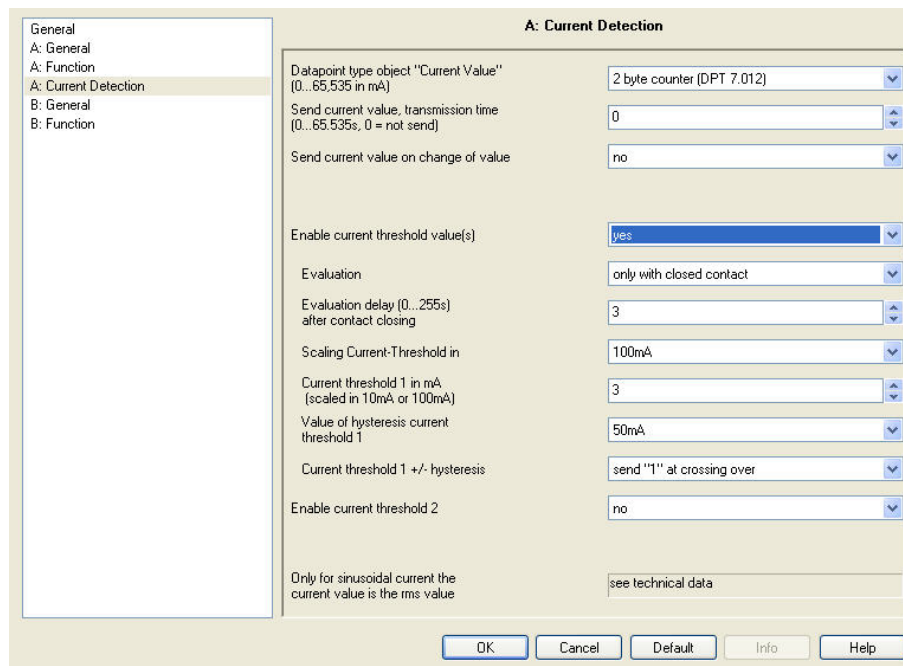

## Enable current threshold value(s)

Options: no  
yes

Up to two current thresholds values can be enabled for detected currents.

- *no*: No current threshold values are enabled.
- *yes*: A current threshold value with the corresponding parameterization option and the communication object *Status Current-Threshold 1* are enabled.

The following parameters appear:

### Evaluation

Options: always  
only with closed contact  
only with open contact

This parameter determines the contact position at which the information *Threshold undershoot* or *Threshold overshoot* is sent.

- *always*: Falling below or exceeding the set current threshold value can be evaluated for both contact positions. This is only sent via KNX if the status changes. As a result, with a contact opened via KNX (current flow interrupted), a current threshold undershoot is always detected (as an error). However, this is only sent when there is a status change.

- *only with closed contact.* Falling below or exceeding the set current threshold value can only be evaluated when the contact is closed. As a result, a current threshold undershoot is never detected (as an error) on a contact opened via KNX (current flow interrupted). The precondition for evaluation to work properly is that the contact is closed by a switch action via KNX. Manual switching is not recognized, the current threshold evaluation is not interrupted. Thus manual switching is interpreted as a circuit-breaker or load fault. The evaluation occurs in accordance with the time set in parameter *Evaluation delay [0...255s] after contact closing*.
- *only with open contact.* Falling below or exceeding the set current threshold value can only be evaluated when the contact is open. In this way, for example, you can immediately detect when a switched-off contact is inadmissibly switched on manually. Evaluation occurs about one second after opening the contact. The time is fixed for system reasons and cannot be influenced. Monitoring occurs not just once after a contact change, but rather continuously (about once a second).

#### **How does evaluation function?**

Current value is detected in accordance with the parameterized contact position. Should it be different to the contact position parameterized on the output of the SA/S, the current value is neither detected nor evaluated. Furthermore, the current value is not recorded during the parameterized evaluation delay and therefore no comparison with the setpoint is undertaken during this period. When the evaluation delay has elapsed, the present current value is recorded and compared with the current threshold value.

The status of the current threshold value is only sent if there is a status change in comparison to the previous status value.

When *only with closed contact* is selected, the current is only detected with a closed contact, compared to the current threshold value, and sent if there has been a change. If the contact is opened, there is no current detection and thus no evaluation. A prerequisite is that the contact is opened by a switching telegram initiated via KNX. Manual switching is not recognized. In this case, the SA/S assumes that there is a cable break or load fault. If current detection goes ahead, the detected current value is compared to the current threshold value, and sent if there has been a status change.

If the value dropped below the threshold before the contact was opened and is still below the threshold after the contact is closed again, the *below threshold value* information is not sent again as the status has not changed.

With the option *always*, the current is detected regardless of the contact position and continuously compared with the current threshold value. But the status of the threshold value is only sent if the status has changed.

#### Example

The SA/S contact is closed and the connected load fails. The undershoot of the current threshold value is detected, and the changed status is sent. The SA/S contact is subsequently opened.

The current flow is zero and still under the threshold. As the status of the current threshold value has not changed, it will not be resent.

The new status is sent only after the next setpoint overshoot.

#### Evaluation delay [0...255s] after contact closing

Options: 0...3...255

With this parameter you can ensure that brief start-up currents or current peaks caused by the switching process do not lead to an unwanted current threshold value signal. This method masks out measured values.

Only after this time has elapsed will the *Status Current-Threshold* be sent via the communication object of the same name, if the threshold value has changed.

- 0: The current threshold values are evaluated immediately after contact change.

#### Scaling Current-Threshold in

Options: 10 mA  
100 mA

This parameter sets the current threshold values grid. These specifications apply for *Current threshold 1* and *Current threshold 2*.

#### Current threshold 1 in mA (scaled in 10mA or 100mA)

Options: 0...3...240

With this parameter, a current threshold value can be entered in 10 or 100 mA steps.

Depending on the parameter *Scaling Current-Threshold in*, a threshold range of 0...2.4 A or 0...24 A results.

## Value of hysteresis current threshold 1

Options: 3/25/50/100/200/500 mA  
1/2/5 A

To avoid a continuously changing threshold value state, the current detection thresholds feature a hysteresis function. The set *Value of hysteresis current threshold* ensures that a current change is only registered as such if it is greater than the hysteresis value. Only then will a change of current threshold value status be sent.

Partly due to fluctuations in the electrical system and the detection accuracy of the current transformers in the Switch Actuator, 3 mA is the smallest hysteresis possible.

For further information see: [Threshold function with current detection](#), p. 142 and [Current detection specifications](#), p. 44

### Please note

No hysteresis is used with the option none. With a highly fluctuating current value this can often lead to frequently changing threshold results. The bus load increases unnecessarily if there is continuous status change.

## Current threshold 1 +/- hysteresis

Options: no sending  
send "0" at crossing over  
send "1" at crossing over  
send "1" at crossing lower  
send "0" at crossing lower  
send "0" at crossing over – "1" at crossing lower  
send "1" at crossing over – "0" at crossing lower

This parameter determines the value of the communication object *Status Current-Threshold 1* when undershooting or overshooting current threshold value 1.

- *no sending*: no telegram is sent when there is a current threshold value overshoot or undershoot
- *send "0" at crossing over*: Should current threshold value 1 be overshoot, communication object *Status Current-Threshold 1* sends the value 0. An undershoot sets the value to 1 but no telegram is sent.
- *send "1" at crossing over*: Should current threshold value 1 be overshoot, communication object *Status Current-Threshold 1* sends the value 1. An undershoot sets the value to 0 but no telegram is sent.
- *send "0" when crossing lower*: Should current threshold value 1 be undershot, communication object *Status Current-Threshold 1* sends the value 0. An overshoot sets the value to 1 but no telegram is sent.

- *send "1" when crossing lower:* Should current threshold value 1 be undershot, communication object *Status Current-Threshold 1* sends the value 1. An overshoot sets the value to 0 but no telegram is sent.
- *send "0" at crossing over – "1" at crossing lower:* Should current threshold value 1 be overshoot, communication object *Status Current-Threshold 1* sends the value 0, or if the threshold is undershot, 1.
- *send "1" at crossing over – "0" at crossing lower:* Should current threshold value 1 be overshoot, communication object *Status Current-Threshold 1* sends the value 1, or if the threshold is undershot, 0.

The status is sent after the evaluation delay at the earliest and only if the status has changed.

## Enable current threshold 2

Options:     no  
                  yes

This parameter enables the second current threshold value and its associated communication object *Status Current-Threshold 2*. The same evaluation delay, scaling, and evaluation properties as for Threshold 1 apply.

- yes: The following parameter appears:

**Current threshold 2 in mA  
(scaled in 10mA or 100mA)**

**Value of hysteresis current  
threshold 2**

**Current threshold 2 +/- hysteresis**

The setting options for this parameter are the same as for current threshold value 1. Parameter descriptions can be found earlier in this section.

**Only for sinusoidal current the  
current value is the rms value**

**see technical data**

# ABB i-bus<sup>®</sup> KNX Commissioning

## 3.2.4 Communication objects, operating mode *Switch Actuator*

### 3.2.4.1 Communication objects, *General*

Number	Object Function	Name	Length	C	R	W	T	U
0	In Operation	General	1 bit	C	R	-	T	-
1	Safety Priority 1	General	1 bit	C	-	W	-	U
2	Safety Priority 2	General	1 bit	C	-	W	-	U
3	Safety Priority 3	General	1 bit	C	-	W	-	U

No.	Function	Object name	Data type	Flags
0	<b>In Operation</b>	<b>General</b>	<b>EIS 1, 1 bit</b> <b>DPT 1.002</b>	<b>C, R, T</b>
<p>To regularly monitor the presence of the Switch Actuator on the ABB i-bus<sup>®</sup>, a monitoring telegram can be sent cyclically via the bus.</p> <p>This communication object is always enabled.</p> <p>Telegram value: 1 = system in operation 0 = send inactive</p>				
1	<b>Safety Priority 1</b>	<b>General</b>	<b>EIS 1, 1 bit</b> <b>DPT 1.005</b>	<b>C, W, U</b>
<p>This communication object is enabled if in the <i>General</i> parameter window, parameter <i>Function Safety Priority 1</i> is set to <i>enabled by object value "0"</i> or <i>enabled by object value "1"</i>.</p> <p>The Switch Actuator can receive a 1 bit telegram via this communication object, which another KNX device, e.g. diagnostics module or wind sensor, sends cyclically. On receipt of the telegram, the communication capability of the bus or the sensor (signaling device) can be monitored. If the Switch Actuator does not receive a telegram on the communication object <i>Safety Priority 1</i> within a certain time (value can be parameterized), a fault is assumed and a response, as parameterized in parameter window <i>A: Safety</i>, is implemented. The Switch Actuator output goes into a safety state and does not process any telegrams. Only after communication object <i>Safety Priority 1</i> receives a 1 or 0 again (depending on the parameterization) will incoming telegrams be processed again and the contact position changed.</p> <p>The monitoring period can be adjusted in the parameter <i>Monitoring time in seconds</i> in the <i>A: General</i> parameter window.</p> <p>Safety Priority 1 is also triggered if a telegram with the parameterizable trigger value is received.</p> <p>With the exception of the reaction on bus voltage failure and recovery, the <i>Safety Priority 1</i> function takes highest priority in the Switch Actuator, (see <a href="#">Function diagram</a>, p. 147).</p>				

# ABB i-bus<sup>®</sup> KNX Commissioning

No.	Function	Object name	Data type	Flags
<b>2</b>	<b>Safety Priority 2</b>	<b>General</b>	<b>EIS 1, 1 bit DPT 1.005</b>	<b>C, W, U</b>
See communication object 1				
<b>3</b>	<b>Safety Priority 3</b>	<b>General</b>	<b>EIS 1, 1 bit DPT 1.005</b>	<b>C, W, U</b>
See communication object 1				
<b>4... 9</b>				
Not assigned				



# ABB i-bus<sup>®</sup> KNX Commissioning

## 3.2.4.2 Communication objects, *Output A*

Number	Object Function	Name	Length	C	R	W	T	U
10	switch	Output A	1 bit	C	-	W	-	-
11	Permanent ON	Output A	1 bit	C	-	W	-	-
12	Disable time function	Output A	1 bit	C	-	W	-	-
13	Duration of staircase lighting	Output A	2 Byte	C	R	W	-	-
14	warning stair lighting	Output A	1 bit	C	-	-	T	-
14	Forced operation	Output A	1 bit	C	-	W	-	-
15	Call preset 1/2	Output A	1 bit	C	-	W	-	-
16	Set preset 1/2	Output A	1 bit	C	-	W	-	-
17	8 bit scene	Output A	1 Byte	C	-	W	-	-
18	Logical connection 1	Output A	1 bit	C	-	W	-	-
19	Logical connection 2	Output A	1 bit	C	-	W	-	-
20	Forced Positioning	Output A	1 bit	C	-	W	-	-
21	Threshold input	Output A	1 Byte	C	-	W	-	-
22	Change Threshold value 1	Output A	1 Byte	C	-	W	-	-
25	Contact monitoring	Output A	1 bit	C	-	-	T	-
26	Current Value	Output A	2 Byte	C	R	-	T	-
26	Current Value	Output A	4 Byte	C	R	-	T	-
27	Status Current-Threshold 1	Output A	1 bit	C	-	-	T	-
28	Status Current-Threshold 2	Output A	1 bit	C	-	-	T	-
29	Status Switch	Output A	1 bit	C	R	-	T	-

### Please note

This product manual describes all the current 2/4/8 and 12-fold Switch Actuators. These devices have 2/4/8 or 12 outputs respectively. However, as the functions for all outputs are identical, only the functions of output A will be described.

Where information in the product manual refers to all outputs, the description output A...X is used. 2-fold corresponds to outputs A...B, 4-fold corresponds to outputs A...D, 8-fold corresponds to outputs A...H and 12-fold corresponds to outputs A...L.

The variants with current detection feature an additional parameter page as well as additional communication objects for this function.

Parameter setting options for outputs A...X are described in [Parameter window A: General](#), p. 66.

# ABB i-bus<sup>®</sup> KNX Commissioning

No.	Function	Object name	Data type	Flags		
10	switch	Output A	EIS 1, 1 bit DPT 1.001	C, W		
<p>This communication object is used for switching the output ON/OFF. The device receives a switch telegram via the switch object.</p> <p>N/O: Telegram value:   1 = switch ON                       0 = switch OFF</p> <p>N/C: Telegram value:   1 = switch OFF                       0 = switch ON</p> <table border="1" style="width: 100%; border-collapse: collapse;"> <thead> <tr> <th style="background-color: #e0e0e0;">Please note</th> </tr> </thead> <tbody> <tr> <td> <p>With logical connections or forced operations, modifying communication object <i>Switch</i> does not necessarily result in a changed contact position. <b>For further information see:</b> <a href="#">Function diagram</a>, p. 147</p> <p>The Switch Actuator does not monitor manual actuation electrically, and therefore cannot react discretely to a manual operation. From a power engineering point of view, the relay is only actuated with a switching pulse if the last known relay position set by the bus has changed. As a consequence, after a one-off manual switching operation, a switch telegram received via the bus triggers no contact changeover because the switch actuator assumes that no changeover has taken place and that the correct contact position is still set. An exception to this situation is after bus voltage failure and recovery. In both cases, the relay position is recalculated based on the parameterization and set independently of the contact position.</p> </td> </tr> </tbody> </table>					Please note	<p>With logical connections or forced operations, modifying communication object <i>Switch</i> does not necessarily result in a changed contact position. <b>For further information see:</b> <a href="#">Function diagram</a>, p. 147</p> <p>The Switch Actuator does not monitor manual actuation electrically, and therefore cannot react discretely to a manual operation. From a power engineering point of view, the relay is only actuated with a switching pulse if the last known relay position set by the bus has changed. As a consequence, after a one-off manual switching operation, a switch telegram received via the bus triggers no contact changeover because the switch actuator assumes that no changeover has taken place and that the correct contact position is still set. An exception to this situation is after bus voltage failure and recovery. In both cases, the relay position is recalculated based on the parameterization and set independently of the contact position.</p>
Please note						
<p>With logical connections or forced operations, modifying communication object <i>Switch</i> does not necessarily result in a changed contact position. <b>For further information see:</b> <a href="#">Function diagram</a>, p. 147</p> <p>The Switch Actuator does not monitor manual actuation electrically, and therefore cannot react discretely to a manual operation. From a power engineering point of view, the relay is only actuated with a switching pulse if the last known relay position set by the bus has changed. As a consequence, after a one-off manual switching operation, a switch telegram received via the bus triggers no contact changeover because the switch actuator assumes that no changeover has taken place and that the correct contact position is still set. An exception to this situation is after bus voltage failure and recovery. In both cases, the relay position is recalculated based on the parameterization and set independently of the contact position.</p>						
11	Permanent ON	Output A	EIS 1, 1 bit DPT 1.001	C, W		
<p>This communication object is enabled if the <i>yes</i> option is selected for parameter <i>Enable time functions</i> in the <i>A: Function</i> parameter window. The output can be forcibly switched on with this communication object. If communication object <i>Permanent ON</i> is assigned the value 1, the output is switched on irrespective of the value of communication object <i>Switch</i> and remains switched on until <i>Permanent ON</i> has the value 0. After ending the permanent ON state, the state of <i>Switch</i> is used. <i>Permanent ON</i> only switches ON and “masks” the other functions. This means that the other functions, e.g. Staircase lighting, continue to run in the background but do not initiate a switching action. When <i>permanent ON</i> ends, the contact position which would result without the <i>permanent ON</i> function becomes active. For the Staircase lighting function, the response after <i>permanent ON</i> can be parameterized in <a href="#">Parameter window A: Time</a>, p. 76. This communication object can be used, for example, to allow service or maintenance and cleaning personnel to initiate a permanent ON. The device receives a switch telegram via the switch object. <i>Permanent ON</i> becomes inactive after a download or bus voltage recovery.</p> <p>Telegram value:   1 = activates Permanent ON mode                       0 = deactivates permanent ON mode</p>						

# ABB i-bus<sup>®</sup> KNX Commissioning

No.	Function	Object name	Data type	Flags
12	<b>Disable time function</b>	<b>Output A</b>	<b>EIS 1, 1 bit DPT 1.003</b>	<b>C, W</b>
<p>This communication object is enabled if the yes option is selected for parameter <i>Enable time functions</i> in the <i>A: Function</i> parameter window.</p> <p><i>In parameter window A: Function, after bus voltage recovery you can set the parameter Value for object "Disable time function" on bus voltage recovery. For an example, see: <a href="#">Time function</a>, p. 148</i></p> <p>If the Time function is disabled, the output can only be switched on or off; the functions <i>Staircase lighting, Delay and Flashing</i> are not triggered.</p> <p>Telegram value:     1 = time function disabled                           0 = time function enabled</p> <p>The contact position at the time of disabling and enabling is retained and will only be changed with the next switch telegram to communication object <i>Switch</i>.</p>				
13	<b>Duration of staircase lighting</b>	<b>Output A</b>	<b>EIS 10, 2 byte DPT 7.005</b>	<b>C, R, W</b>
<p>This communication object is enabled if the option <i>yes</i> has been selected for parameter <i>Duration of staircase lighting can be changed by object</i> in parameter window <i>A: Time</i>.</p> <p>The duration of staircase lighting is set here. The time is entered in seconds. After bus voltage recovery, the communication object value is set by the parameterized value, and the value set via the bus is overwritten.</p>				
14	<b>warning stair lighting</b>	<b>Output A</b>	<b>EIS 1, 1 bit DPT 1.005</b>	<b>C, T</b>
<p>This communication object is enabled if the Staircase lighting function is selected in parameter window <i>A: Time</i> and if <i>via object</i> or <i>via object and switching ON/OFF</i> have been selected in parameter <i>Warning before end of staircase lighting</i>.</p>				
15	<b>Call preset 1/2</b>	<b>Output A</b>	<b>EIS 1, 1 bit DPT 1.002</b>	<b>C, W</b>
<p>This communication object is enabled if the yes option is selected for parameter <i>Enable function "presets"</i> in the <i>A: Function</i> parameter window.</p> <p>This communication object recalls a stored contact position.</p> <p>Through a recall of Preset 1/2 with the corresponding parameterization, you can restore the contact position before the recall of Preset 2 or reset it to the parameterized value before Preset 2.</p> <p>Telegram value:     0 = Recalls the parameterized value (contact position) of Preset 1.                           1 = Recalls the parameterized value (contact position) of Preset 2.</p> <p><b>For further information see: <a href="#">Preset function</a>, p. 155</b></p>				

No.	Function	Object name	Data type	Flags																																			
16	<b>Set preset 1/2</b>	<b>Output A</b>	<b>EIS 1, 1 bit</b> <b>DPT 1.002</b>	<b>C, W</b>																																			
<p>This communication object is enabled if the <i>yes</i> option is selected for parameter <i>Enable function "presets"</i> in the <i>A: Function</i> parameter window.</p> <p>Using this communication object, the current contact position can be stored as the new preset value.</p> <p>Telegram value:   0 = Stores the current contact position as Preset 1.                       1 = Stores the current contact position as Preset 2.</p> <p><b>For further information see: <a href="#">Preset function</a>, p. 155</b></p>																																							
17	<b>8 bit scene</b>	<b>Output A</b>	<b>1 byte Non EIS</b> <b>DPT 18.001</b>	<b>C, W</b>																																			
<p>This communication object is enabled if the <i>yes</i> option is selected for parameter <i>Enable function "scene (8 bit)"</i> in the <i>A: Function</i> parameter window.</p> <p>Using this 8 bit communication object, a scene telegram can be sent using a coded telegram. The telegram contains the number of the scene concerned as well as the information on whether the scene is to be recalled or if the current contact position is to be assigned to the scene.</p> <p>Telegram format (1 byte):   MXSSSSSS                                   (MSB) (LSB)</p> <p>                                  M:    0 – Recalls the scene                                       1 – Stores the scene (if allowed)</p> <p>                                  X:    not used</p> <p>                                  S:    Scene number (1...64: 00000000...00111111)</p> <table border="1" style="margin-left: auto; margin-right: auto;"> <thead> <tr> <th colspan="2">KNX 1 byte telegram value</th> <th rowspan="2">Meaning</th> </tr> <tr> <th>Decimal</th> <th>Hexadecimal</th> </tr> </thead> <tbody> <tr> <td>00 or 64</td> <td>00h or 40h</td> <td>Recall scene 1</td> </tr> <tr> <td>01 or 65</td> <td>01h or 41h</td> <td>Recall scene 2</td> </tr> <tr> <td>02 or 66</td> <td>02h or 42h</td> <td>Recall scene 3</td> </tr> <tr> <td>...</td> <td>...</td> <td>...</td> </tr> <tr> <td>63 or 127</td> <td>3Fh or 7Fh</td> <td>Recall scene 64</td> </tr> <tr> <td>128 or 192</td> <td>80h or B0h</td> <td>Store scene 1</td> </tr> <tr> <td>129 or 193</td> <td>81h or B1h</td> <td>Store scene 2</td> </tr> <tr> <td>130 or 194</td> <td>82h or B2h</td> <td>Store scene 3</td> </tr> <tr> <td>...</td> <td>...</td> <td>...</td> </tr> <tr> <td>191 or 255</td> <td>AFh or FFh</td> <td>Store scene 64</td> </tr> </tbody> </table> <p><b>For further information see: <a href="#">Scene function</a>, p. 156 and <a href="#">Code table, 8 bit scene</a>, p. 171</b></p>					KNX 1 byte telegram value		Meaning	Decimal	Hexadecimal	00 or 64	00h or 40h	Recall scene 1	01 or 65	01h or 41h	Recall scene 2	02 or 66	02h or 42h	Recall scene 3	...	...	...	63 or 127	3Fh or 7Fh	Recall scene 64	128 or 192	80h or B0h	Store scene 1	129 or 193	81h or B1h	Store scene 2	130 or 194	82h or B2h	Store scene 3	...	...	...	191 or 255	AFh or FFh	Store scene 64
KNX 1 byte telegram value		Meaning																																					
Decimal	Hexadecimal																																						
00 or 64	00h or 40h	Recall scene 1																																					
01 or 65	01h or 41h	Recall scene 2																																					
02 or 66	02h or 42h	Recall scene 3																																					
...	...	...																																					
63 or 127	3Fh or 7Fh	Recall scene 64																																					
128 or 192	80h or B0h	Store scene 1																																					
129 or 193	81h or B1h	Store scene 2																																					
130 or 194	82h or B2h	Store scene 3																																					
...	...	...																																					
191 or 255	AFh or FFh	Store scene 64																																					

# ABB i-bus<sup>®</sup> KNX Commissioning

No.	Function	Object name	Data type	Flags								
18	Logical connection 1	Output A	1 bit (EIS 1) DPT 1.002	C, W								
<p>This communication object is enabled if the yes option is selected for parameter <i>Enable function "logic"</i> in parameter window A: <i>Function</i></p> <p>Using this communication object, the output of the first of two logic objects can be assigned. The logical connection is defined in the parameter window A: <i>Logic</i>.</p> <p>Initially this links the switch object logically with communication object <i>Logical connection 1</i>. The result of this is then linked with communication object <i>Logical connection 2</i>.</p>												
<table border="1"> <thead> <tr> <th colspan="2">Please note</th> </tr> </thead> <tbody> <tr> <td colspan="2">The values of communication objects <i>Logical connection 1/2</i> are stored on bus voltage failure. The values are set again after bus voltage recovery</td> </tr> <tr> <td colspan="2">If values are not assigned for the communication objects <i>Logical Connection 1/2</i>, they will be deactivated.</td> </tr> <tr> <td colspan="2">On reset via the bus, the values of communication objects Logical Connection 1/2 remain unchanged.</td> </tr> </tbody> </table>					Please note		The values of communication objects <i>Logical connection 1/2</i> are stored on bus voltage failure. The values are set again after bus voltage recovery		If values are not assigned for the communication objects <i>Logical Connection 1/2</i> , they will be deactivated.		On reset via the bus, the values of communication objects Logical Connection 1/2 remain unchanged.	
Please note												
The values of communication objects <i>Logical connection 1/2</i> are stored on bus voltage failure. The values are set again after bus voltage recovery												
If values are not assigned for the communication objects <i>Logical Connection 1/2</i> , they will be deactivated.												
On reset via the bus, the values of communication objects Logical Connection 1/2 remain unchanged.												
<p><b>For further information see: Logic function, p. 153</b></p>												
19	Logical connection 2	Output A	1 bit (EIS 1) DPT 1.002	C, W								
<p>See communication object 18.</p>												
20	Forced operation	Output A	1 bit (EIS 1) DPT 1.003	C, W								
<p>This communication object is enabled if in parameter window A: <i>Function</i> the yes option has been selected for parameter <i>Enable functions "priority and safety operation"</i> and <i>1 bit object</i> is selected for parameter <i>Contact position if forced operation</i>.</p> <p>If the communication object receives the value 1, the output is forcibly set to the parameterized contact position, which has been set in the A: <i>Safety</i> parameter window. The forced positioning of the contact remains until forced operation is ended when communication object <i>Forced operation</i> receives a 0.</p> <p>Please note that the function <i>Safety Priority 1</i> and a bus failure have a higher priority on the contact position: see <a href="#">Function diagram</a>, p. 147.</p>												

# ABB i-bus<sup>®</sup> KNX Commissioning

No.	Function	Object name	Data type	Flags
20	<b>Forced Positioning</b>	<b>Output A</b>	<b>2 bit (EIS 8)</b> <b>DPT 2.001</b>	<b>C, W</b>
<p>This communication object is enabled if in parameter window A: <i>Function</i> the <i>yes</i> option has been selected for parameter <i>Enable functions "priority and safety operation"</i> and <i>2 bit object</i> is selected for parameter <i>Contact position if forced operation</i>. The output can be forcibly operated via this communication object (e.g. by a higher-level control). The communication object value directly defines the forced position of the contact:</p> <p>0 or 1 = The output is not forcibly operated. 2 = The output is forcibly switched off. 3 = The output is forcibly switched on.</p> <p>At the end of the forced operation, a check is performed to see if one of the three <i>Safety Priority x</i> functions (<math>x = 1, 2</math> and <math>3</math>) is active. If necessary, the contact position is set by the active safety priorities. If no <i>Safety Priority x</i> is active, the parameter used is the one set in parameter window A: <i>Safety</i>, for parameter <i>Reaction when forced operation and all Safety Priority x end</i>. Please note that the function <i>Safety Priority 1</i> and a bus failure have a higher priority on the contact position: see <a href="#">Function diagram</a>, p. 147.</p>				
21	<b>Threshold input</b>	<b>Output A</b>	<b>1 byte (EIS 6)</b> <b>2 byte (EIS 10)</b> <b>DPT 5.010</b> <b>DPT 7.001</b>	<b>C, W</b>
<p>This communication object is enabled if the <i>yes</i> option is selected for parameter <i>Enable function "threshold"</i> in the A: <i>Function</i> parameter window. Depending on the selection made in parameter window A: <i>Threshold</i>, a 1 byte (integer value) or 2 byte (counter value) communication object is enabled. If the threshold value parameterized in window A: <i>Threshold</i> is overshoot, a switching action can be performed.</p>				
22	<b>Change Threshold value 1</b>	<b>Output A</b>	<b>1 byte (EIS 6)</b> <b>2 byte (EIS 10)</b> <b>DPT 5.010</b> <b>DPT 7.001</b>	<b>C, W</b>
<p>This communication object is enabled if the <i>yes</i> option has been selected for parameter <i>Change Threshold 1 over bus</i> in parameter window A: <i>Threshold</i>. Depending on the selection made in parameter window A: <i>Threshold</i>, a 1 byte (integer value) or 2 byte (counter value) communication object is enabled. If the communication object <i>Change Threshold value 1</i> is enabled, the threshold value can be changed via the bus.</p>				
23...				
24				
Not assigned				

# ABB i-bus<sup>®</sup> KNX Commissioning

No.	Function	Object name	Data type	Flags
25	<b>Contact monitoring</b>	<b>Output A</b>	<b>EIS 1, 1 bit DPT 1.002</b>	<b>C, T</b>
<p>This communication object is enabled if the yes option is selected for parameter <i>Enable function "current detection"</i> in the <i>A: Function</i> parameter window.</p> <p>The communication object value shows the contact state when the contact is open.</p> <p>Should a current flow be detected on a contact opened via KNX, contact welding or manual switch on has occurred (contact error). Evaluation of whether a current is flowing occurs about one second after a contact is opened. Current will definitely be detected if a measurable current (about 20 mA) is flowing. For evaluation to work properly, switching must be done via KNX.</p> <p>Telegram value     1 = contact error                           0 = no current is flowing</p>				
26	<b>Current Value</b>	<b>Output A</b>	<b>EIS10, 2 byte DPT 7.012</b>	<b>C, R, T</b>
<p>This communication object is enabled if the yes option is selected for parameter <i>Enable function "current detection"</i> in the <i>A: Function</i> parameter window and the 2 byte datapoint type is selected in the <i>A: Current Detection</i> parameter window.</p> <p>The presently detected current is sent via KNX; 1 digit corresponds to 1 mA.</p> <p><b>For further information see: <a href="#">Current detection specifications</a>, p. 44</b></p>				
26	<b>Current Value</b>	<b>Output A</b>	<b>EIS 9, 4 byte DPT 14.019</b>	<b>C, R, T</b>
<p>This communication object is enabled if the yes option is selected for parameter <i>Enable function "current detection"</i> in the <i>A: Function</i> parameter window and the 4 byte datapoint type is selected in the <i>A Current Detection</i> parameter window</p> <p>The current value is transferred via KNX as a mA value.</p> <p><b>For further information see: <a href="#">Current detection specifications</a>, p. 44</b></p>				
27	<b>Status Current-Threshold 1</b>	<b>Output A</b>	<b>EIS 1, 1 bit DPT 1.002</b>	<b>C, T</b>
<p>This communication object is enabled if the yes option is selected for parameter <i>Enable current threshold value(s)</i> in the <i>A: Current Detection</i> parameter window.</p> <p>The status of current threshold value 1 is only sent when a change occurs.</p> <p>The status value can be inverted.</p> <p>Telegram value     1 = threshold value 1 plus threshold value 1 hysteresis is exceeded                           0 = threshold value 1 minus threshold value 1 hysteresis is not exceeded</p> <p><b>For further information see: <a href="#">Threshold function with current detection</a>, p. 142</b></p>				

# ABB i-bus<sup>®</sup> KNX Commissioning

28	Status Current-Threshold 2	Output A	EIS 1, 1 bit DPT 1.002	C, T
<p>This communication object is enabled if the <i>yes</i> option is selected for parameter <i>Enable current threshold value(s)</i> and <i>Enable threshold value 2</i> in the <i>A: Current Detection</i> parameter window.</p> <p>The status of current threshold value 2 is only sent when a change occurs.</p> <p>The status value can be inverted.</p> <p>Telegram value      1 = threshold value 2 plus threshold value 2 hysteresis is exceeded                                  0 = threshold value 2 minus threshold value 2 hysteresis is not exceeded</p> <p><b>For further information see:</b> <a href="#">Threshold function with current detection</a>, p. 142</p>				
29	Status Switch	Output A	EIS 1, 1 bit DPT 1.001	C, R, T
<p>This communication object is enabled if the options <i>only after changing</i> or <i>always</i> are selected for parameter <i>Status response of switching state Object "Status Switch"</i> response in parameter window <i>A: General</i>.</p> <p>The communication object value directly indicates the current contact position of the switching relay.</p> <p>The status value can be inverted.</p> <p>Telegram value      1 = relay ON or OFF depending on the parameterization                                  0 = Relay OFF or ON depending on the parameterization</p>				



## 3.2.5 Operating mode *Heating Actuator*

In *Heating Actuator* operating mode the Switch Actuators are generally used as setting elements for electro-thermal valve drives. Room temperature can be controlled in conjunction with a room thermostat or room thermometer which controls the Switch Actuator.

Various types of control are possible, e.g. PWM, 2-point control (1 bit) or continuous control (1 byte).

Every individual output of a Switch Actuator can be controlled via a 1 bit control value. For this purpose, the *Switch* communication objects for the outputs have to be connected with the *Control value* communication objects of the room thermostats/temperature controllers.

### Please note

The parameters of the room thermostat must be set to *continuous 2-point control* or *switching 2-point control*.

With so-called continuous control, a 1 byte value [0...255] is used as an input signal. This input signal is used in the Switch Actuator in accordance with the parameterizable cycle time in the ON and OFF command of the switch relay. At 0 %, the valve is closed, and at 100 % it is fully open. Intermediate values are calculated via pulse width modulation (PWM).

For further information see: [Pulse width modulation – calculation](#), p. 164

### Please note

Electromechanical Switch Actuators, including SA/S Switch Actuators, have mechanical contacts. On the one hand this achieves electrical isolation and very high switching capacity, on the other it is associated with switching noise and mechanical wear.

### Important

When *Heating Actuator* operating mode is selected, the service life of the switching contacts must be considered, see [Technical data](#), from p. 9.

This is essential if the output is used as a continuous controller.

Considering these aspects, it can be useful to use an Electronic Switch Actuator, Fan Coil Actuator or Fan Coil Controller from the ABB i-bus<sup>®</sup> KNX range. These actuators do not feature electrical isolation and have a considerably smaller, but quite sufficient, switching capacity. Mechanical wear and switching noises are not an issue.

## Please note

The current detection function and associated parameter window is only visible on Switch Actuators with current detection (SA/S x.16.6.1). It offers the same functionality in both Switch Actuator and Heating Actuator modes.

The screenshot shows the 'A: General' parameter window. On the left, a tree view lists 'General', 'A: General', 'A: Function', 'B: General', and 'B: Function'. The main area contains the following parameters:

Parameter	Value
Operating mode of output A	Heating Actuator
Status response of switching state Object "Status Switch"	only after changing
Object value switching status (Object "Status Switch")	1=closed, 0=open
Reaction on bus voltage failure	Contact unchanged
Connected valve type	normally closed
Control telegram is received as	1 bit (PWM or on-off control)
PWM-cycle time for continuous control Minutes (3...65.535)	10
PWM-cycle time for continuous control Seconds (0...59)	0
Position of the valve drive on bus voltage recovery	0% (closed)

Buttons at the bottom: OK, Cancel, Default, Info, Help.

## Status response of switching state Object "Status Switch"

Options:     no  
              only after changing  
              always

This parameter enables the communication object *Status Switch*. This contains the current switch state i.e. contact position.

- *no*: The contact position is updated but the status is not actively sent via the bus.
- *only after changing*: When the contact position changes, communication object *Status Switch* actively sends the status via the bus. This can have a major effect on the bus load on a Switch Actuator with multiple outputs.
- *always*: The status of the contact position is always actively sent via the bus via communication object *Status Switch*, even when no status change has occurred. Transmission is triggered as soon as communication objects *Control value (PWM)* or *Valve purge* receive a telegram.

## Please note

After parameterization changes or subsequently switching off the status object, the existing assignment of group addresses to the *Switch* communication object is lost and needs to be re-allocated.

# ABB i-bus<sup>®</sup> KNX Commissioning

The status value to be sent is defined using the parameter *Object value switching status* (Object "Status Switch").

## Please note

The contact position is determined by a sequence of priorities and logical connections – see [Function diagram](#), p. 161.

The contact position can only be correctly evaluated if the switching actions occur via KNX. The SA/S cannot differentiate between manual switching and a cable break or device fault.

## Object value switching status (Object "Status Switch")

Options:     1=closed, 0=open  
              0=closed, 1 open

- *1=closed, 0=open*: The value 1 is written to communication object *Status Switch* for a closed contact, 0 for an open contact.
- *0=closed, 1=open*: The value 0 is written to communication object *Status Switch* for a closed contact, 1 for an open contact.

The reaction of the heating valve is dependent on the position of the Switch Actuator relay and the valve type (normally open or normally closed).

## Reaction on bus voltage failure

Options:     Contact open  
              Contact closed  
              Contact unchanged

This parameter defines how the contacts and accordingly the valve drives are controlled on bus voltage failure.

For further information see: [Reaction on bus voltage failure, recovery and download](#), p. 166

Only enough energy for a switching action is available when the bus voltage fails.

If a normally closed valve is used, a closed contact means an open valve (100 %) or a closed valve (0 %) if the contact is open.

If a normally open valve is used, a closed contact means a closed valve (100 %) or an open valve (0 %) if the contact is open.

A middle position cannot be set for the valve on bus voltage failure. It moves either to its closed (0%) or open (100%) end position.

## Connected valve type

Options: normally closed  
normally open

This parameter sets the valve type for the connected valve.

### How does a de-energized closed (normally closed) valve react?

If no current is flowing in the control circuit, the valve closes.  
The valve opens as soon as current is flowing in the control circuit.

### How does a de-energized opened (normally open) valve react?

If no current is flowing in the control circuit, the valve opens.  
The valve closes as soon as current is flowing in the control circuit.

## Control telegram is received as

The heating actuator can either be controlled via the 1 bit communication object *Switch* or the 1 byte communication object *Control value (PWM)*.

Options: 1 bit (PWM or on-off control)  
1 byte (continuous)

- *1 bit (PWM or on-off control)*: The room thermostat controls the heating actuator via standard switching telegrams. This enables on-off control of the control value. The 1 bit value can also originate from pulse width modulation (PWM) calculated by a room thermostat. During a malfunction when the control signal is not received by the room thermostat, the Switch Actuator will undertake an autonomous PWM calculation. The SA/S uses the parameterizable PWM cycle time for this.
- *1 byte (continuous)*: A value of 0...255 (corresponds to 0 %...100 %) is preset by the room thermostat. This process is also known as "continuous-action control". At 0 % the valve is closed and at 100 %, fully open. The heating actuator controls intermediate values via pulse width modulation.

For further information see: [Pulse width modulation \(PWM\)](#), p. 163 and [Pulse width modulation – calculation](#), p. 164

With 1 byte (*continuous*) selected, an additional parameter appears:

### Transmit status response Object "Status heating"

Options:     no  
              yes, 0% = "0" otherwise "1" (1 bit)  
              yes, 0% = "1" otherwise "0" (1 bit)  
              yes, continuous control value (1 byte)

This parameter is only visible with continuous control with a 1 byte value.

For 2-step control the current control value is synonymous with communication object *Status Switch*.

- *no*: A control value is not reported back.
- *yes, 0% = "0" otherwise "1" (1 bit) and 0% = "1" otherwise "0" (1 bit)*: enables communication object *Status heating (1 bit)*. The current control value is sent.
- *yes, continuous control value (1 byte)*: enables communication object *Status heating (1 byte)*. The current control value is sent.

### PWM-cycle time for continuous control Minutes [3...65,535]

Options:     3...10...65,535

### PWM-cycle time for continuous control Seconds [0...59]

Options:     0...59

With 1 bit control this time setting is only used during control of the actuator in fault mode, with the Forced operation function and directly after bus voltage recovery.

With 1 byte control (continuous control), this setting determines the duration of the control signals. This corresponds with the cycle time  $t_{CYC}$ .

The time has been limited to three minutes to suit the endurance of the switch relay, as the number of relay switching operations is limited.

For further information see: [Pulse width modulation \(PWM\)](#), p. 163 and [Lifetime examination of a PWM control](#), p. 165

### Position of the valve drive on bus voltage recovery

Options     0% (closed)  
              10% (26)  
              ...  
              90% (230)  
              100% (open)

This parameter sets how the valve drive is set after bus voltage recovery until the first switching or positioning telegram is received from the room thermostat. The Switch Actuator uses PWM control with the parameterized PWM cycle time until the room thermostat sends a signal.

The value in brackets corresponds to the 1 byte value.

## 3.2.5.1 Parameter window *A: Function*

In this parameter window you determine the response (reaction) of the output and can enable different functions, which makes further parameter windows available.

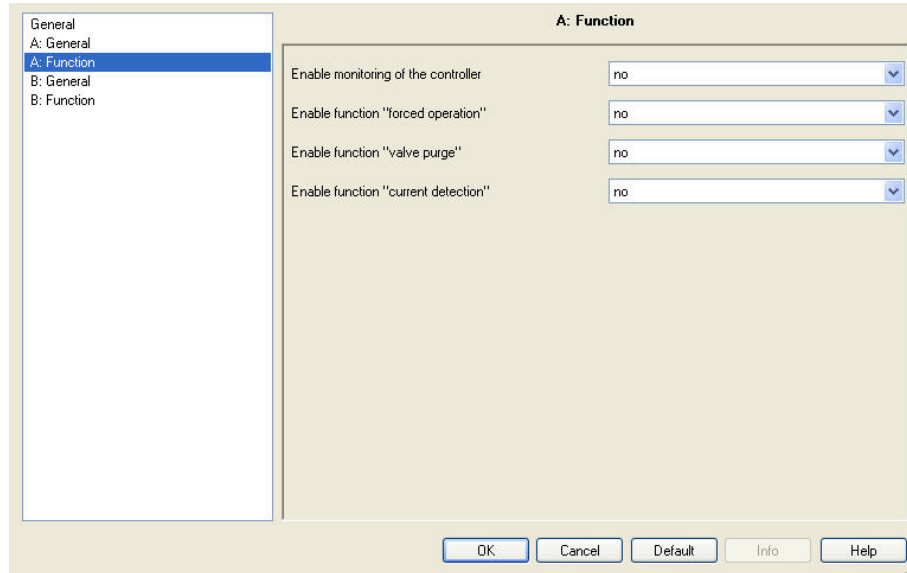

### Enable monitoring of the controller

Options:     no  
              yes

- *no*: Parameter window *A: Monitoring* is not enabled for output A.
- *yes*: Parameter window *A: Monitoring* is enabled for output A. There the communication object *RTR fault* can be enabled for monitoring. Thus a failure of the room thermostat can be detected, the output changed to fault mode and a parameterized valve position can be set.

### Enable function "forced operation"

Options:     no  
              yes

With forced operation, the output can assume a determined position, e.g. for inspection purposes.

- *no*: Parameter window *A: Forced Operation* is not enabled for output A.
- *yes*: Parameter window *A: Forced Operation* and communication object *Forced Operation* are enabled for output A.

# ABB i-bus<sup>®</sup> KNX Commissioning

## Enable function "valve purge"

Options:     no  
              yes

Cyclic valve purge prevents deposits from forming in the valves.

- *no*: Parameter window A: *Valve Purge* is not enabled for output A.
- *yes*: Parameter window A: *Valve Purge* and communication objects *Trigger valve purge* and *Status valve purge* are enabled for output A.

## Enable function "current detection"

Options:     no  
              yes

- *no*: Parameter window A: *Current Detection* is not enabled for output A.
- *yes*: Parameter window A: *Current detection*, and communication object *Contact monitoring*, are enabled for output A.

Please note
These parameters and their functions are only visible for Switch Actuators with current detection. The actuators with integrated current detection are recognizable by a number 6 as the third number of the type designation, e.g. SA/S 2.16.6.1.

## Send status via object "contact monitoring"

Options:     no  
              only after changing  
              always

The send behavior of the communication object *Contact monitoring* can be parameterized by this parameter. A contact fault is indicated via communication object *Contact monitoring*. An error (value 1) is displayed as soon as a current of about 30 mA (observe the tolerances) is detected on an open contact.

- *no*: The value of the communication object is always updated but not sent.
- *always*: The switch status is updated and always sent when the contact is opened. No value is sent when closing it. The reset status is only sent the next time the contact is opened.
- *only after changing*: A telegram is only sent if the value of communication object *Contact monitoring* changes. This can have a major impact on bus load, particularly for Switch Actuators with multiple outputs.

### Important

The contact position can only be correctly evaluated if the switching actions occur via KNX. The SA/S cannot differentiate between manual switching and a cable break or device fault.  
Evaluation of the contact monitoring occurs about two seconds after opening the contact.



## 3.2.5.1.1 Parameter window A: Monitoring

All settings for the *Monitoring* function are undertaken in this parameter window.

This parameter is visible if parameter *Enable monitoring of the controller* has been enabled in [Parameter window A: Function](#), p. 124.

A: Monitoring	
Cyclic monitoring time of room thermostat	
in seconds [0...59]	0
in minutes [0...65,535]	60
Position of the valve drive during fault of room thermostat	unchanged
Enable object "RTR fault"	no

### Cyclic monitoring time of room thermostat

#### in seconds [0...59]

Options: 0...59

#### in minutes [0...65,535]

Options: 0...60...65,535

Telegrams from the room thermostat are transferred to the Switch Actuator at specific intervals. If one or more of the consecutive telegrams is omitted, this may indicate a communications fault or a room thermostat malfunction.

If communication objects *Switch* or *Control value (PWM)* receive no telegrams during the period defined in this parameter, the output switches to fault mode and triggers a safety position. Fault mode ends as soon as a telegram is received as a control value.

#### Please note

If this parameter window is visible, the room thermostat must send the control value cyclically, otherwise no monitoring function is possible.

The monitoring time should be twice as long as the sending cycle time, to ensure that a one-time absent signal does not immediately trigger an error.

## Position of the valve drive during fault of room thermostat

Options:     unchanged  
              0% (closed)  
              10% (26)  
              ...  
              90% (230)  
              100% (open)

This parameter determines the safety position that the SA/S controls in error mode. The value in brackets corresponds to the 1 byte value.

The switch cycle time  $t_{CYC}$  used for control should be set via the parameter *PWM-cycle time for continuous control* in parameter window A: *General*.

## Enable object "RTR fault"

Options:     no  
              yes

This parameter enables communication object *RTR fault*. In fault mode the communication object has the value 1, if there is no fault the value is 0.

## 3.2.5.1.2 Parameter window A: Forced Operation

All settings for the *Forced Operation* function are undertaken in this parameter window.

This parameter window is visible if the *Enable function "forced operation"* parameter has been enabled in [Parameter window A: Function](#), p. 124.

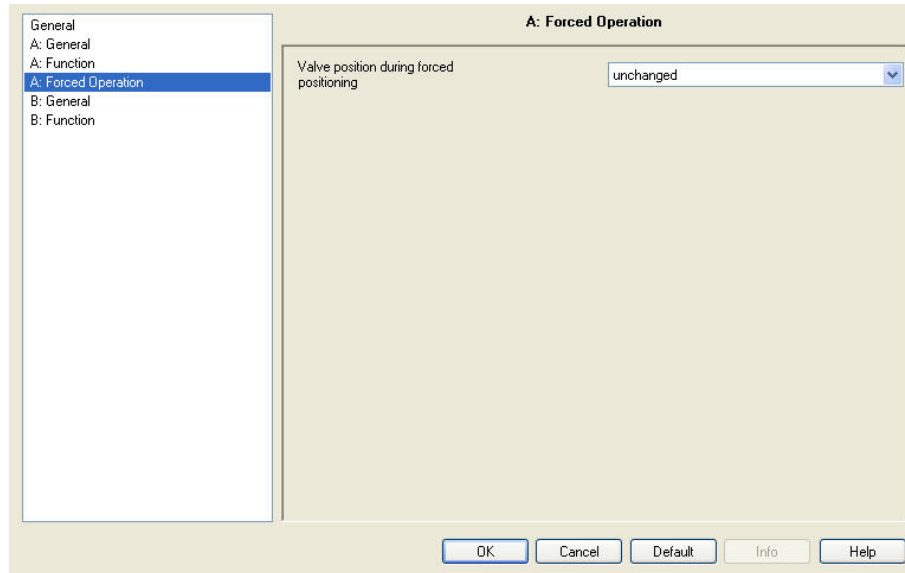

During a forced operation, the Switch Actuator triggers a freely adjustable forced position. This has the highest priority, i.e. it is not modified by a valve purge or safety position.

Forced operation can be activated via communication object *Forced operation* = "1" and deactivated via *Forced operation* = "0".

### Valve position during forced positioning

Options:     unchanged  
              0% (closed)  
              10% (26)  
              ...  
              90% (230)  
              100% (open)

The valve position triggered by the actuator during the forced operation is determined by this parameter. The value in brackets corresponds to the 1 byte value.

The switch cycle time  $t_{CYC}$  used for control should be set in the parameter *cycle time* for continuous control in parameter window A: *General*.

When forced operation ends the Switch Actuator returns to its normal method of operation and calculates its next contact position value from the incoming values on communication objects *Switch* or *Control value (PWM)*.

## 3.2.5.1.3 Parameter window A: Valve Purge

All settings for the *Valve Purge* function are undertaken in this parameter window.

This parameter window is visible if the *Enable function "valve purge"* parameter has been enabled in [Parameter window A: Function](#), p. 124.

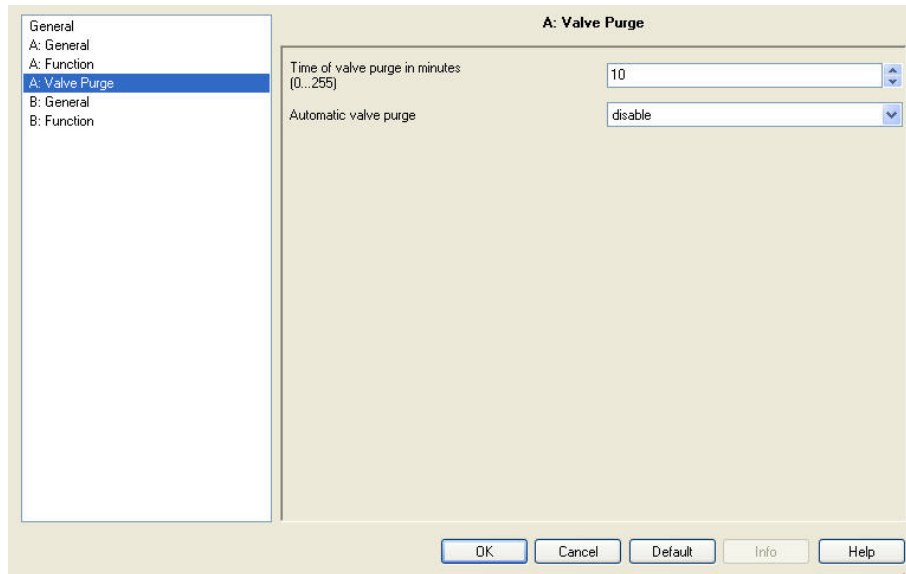

Regular purging of a heating valve can prevent deposits from forming in the valve area and restricting the valve function. This is particularly important at times when the valve position does not change very much. The valve is opened to the maximum during a valve purge. It can be triggered via the communication object *Trigger valve purge* and/or automatically at adjustable intervals.

### **Time of valve purge in minutes [0...255]**

Options: 1...10...255

This parameter sets the duration of the valve purge.

During this time, the valve is fully opened. When the time has elapsed, the state before the purge is re-established.

#### **Please note**

The opening time of the valve must be considered when entering the purge time.

# ABB i-bus<sup>®</sup> KNX Commissioning

## Automatic valve purge

Options:     disable  
              one times per day  
              one times per week  
              one times per month

The counter for automatic purging starts to run when the parameter is downloaded. The time is reset each time it is downloaded.

The time is reset as soon as purging is completed. This can occur either through automatic purging or via communication object *Trigger valve purge*.

### Please note

Purging can also be triggered via the bus, with the communication object *Trigger valve purge*.

After bus voltage recovery and download the purge cycle continues, the bus failure time – the time for which the bus actually failed – is not considered.

An intermediate switching operation of the Switch Actuator relay does not affect the time, as there is no assurance that the valve stroke required for purging has been carried out.

## 3.2.5.1.4 Parameter window A: *Current Detection*

All settings for the *Current Detection* function are undertaken in this parameter window.

This parameter window is visible if the *Enable function "current detection"* parameter has been enabled in [Parameter window A: Function](#), p. 124.

### **Please note**

The current detection function and associated parameter window is only visible on Switch Actuators with current detection (SA/S x.16.6.1). It offers the same functionality in both Switch Actuator and Heating Actuator modes.

As the function is the same for both modes, please refer to the descriptions of the parameter setting options and adjustable communication objects from parameter window [Parameter window A: Current Detection](#), p. 101.

# ABB i-bus<sup>®</sup> KNX Commissioning

## 3.2.6 Communications objects, operating mode *Heating Actuator*

### 3.2.6.1 Communication objects, *General*

Number	Object Function	Name	Length	C	R	W	T	U
0	In Operation	General	1 bit	C	R	-	T	-
1	Safety Priority 1	General	1 bit	C	-	W	-	U
2	Safety Priority 2	General	1 bit	C	-	W	-	U
3	Safety Priority 3	General	1 bit	C	-	W	-	U

No.	Function	Object name	Data type	Flags
<b>0</b>	<b>In Operation</b>	<b>General</b>	<b>EIS 1, 1 bit DPT 1.002</b>	<b>C, R, T</b>
<p>To regularly monitor the presence of the Switch Actuator on the ABB i-bus<sup>®</sup>, a monitoring telegram can be sent cyclically via the bus.</p> <p>This communication object is always enabled.</p> <p>Telegram value:    1 = system in operation                       0 = send inactive</p>				
<b>1</b>	<b>Safety Priority 1</b>	<b>General</b>	<b>EIS 1, 1 bit DPT 1.005</b>	<b>C, W, U</b>
<p>This communication object is enabled if the option <i>enabled by object value "0"</i> or <i>enabled by object value "1"</i> is selected for parameter <i>Function Safety Priority 1</i> in the <i>General</i> parameter window.</p> <p>The Switch Actuator can receive a 1 bit telegram via this communication object, which another KNX device, e.g. diagnostics module or wind sensor, sends cyclically. On receipt of the telegram, the communication capability of the bus or the sensor (signaling device) can be monitored. If the Switch Actuator does not receive a telegram on the communication object <i>Safety Priority 1</i> within a certain time (value can be parameterized), a fault is assumed and a response, as parameterized in parameter window <i>A: Safety</i>, is implemented. The output of the Switch Actuator goes into a safety state and does not process any telegrams. Only after communication object <i>Safety Priority 1</i> receives a 1 or 0 again (depending on the parameterization) will incoming telegrams be processed again and the contact position changed.</p> <p>The monitoring period can be adjusted in the parameter <i>Monitoring time in seconds</i>.</p> <p>Safety Priority 1 is also triggered if a telegram with the parameterizable trigger value is received.</p>				

# ABB i-bus<sup>®</sup> KNX Commissioning

No.	Function	Object name	Data type	Flags
<b>2</b>	<b>Safety Priority 2</b>	<b>General</b>	<b>EIS 1, 1 bit DPT 1.005</b>	<b>C, W, U</b>
See communication object 1				
<b>3</b>	<b>Safety Priority 3</b>	<b>General</b>	<b>EIS 1, 1 bit DPT 1.005</b>	<b>C, W, U</b>
See communication object 1				
<b>4... 9</b>				
Not assigned				



# ABB i-bus<sup>®</sup> KNX Commissioning

## 3.2.6.2

### Communication objects, *Output A*

#### Please note

This product manual describes all the current 2/4/8 and 12-fold Switch Actuators. These devices have 2/4/8 or 12 outputs respectively. However, as the functions for all outputs are identical, only the functions of output A will be described.

Where information in the product manual refers to all outputs, the description output A...X is used. 2-fold corresponds to outputs A...B, 4-fold corresponds to outputs A...D, 8-fold corresponds to outputs A...H and 12-fold corresponds to outputs A...L.

The variants with current detection feature an additional parameter page as well as additional communication objects for this function.

Parameter options for *outputs A...X* are described in [Parameter window A: General](#), p. 66.

Number	Object Function	Name	Length	C	R	W	T	U	I
10	switch	Output A	1 bit	C	-	W	-	-	
11	Trigger valve purge	Output A	1 bit	C	-	W	-	-	
12	Status valve purge	Output A	1 bit	C	-	-	T	-	
13	RTR fault	Output A	1 bit	C	-	-	T	-	
14	Forced operation	Output A	1 bit	C	-	W	-	-	
25	Contact monitoring	Output A	1 bit	C	-	-	T	-	
26	Current Value	Output A	2 Byte	C	R	-	T	-	
27	Status Current-Threshold 1	Output A	1 bit	C	-	-	T	-	
28	Status Current-Threshold 2	Output A	1 bit	C	-	-	T	-	
29	Status Switch	Output A	1 bit	C	R	-	T	-	

Number	Object Function	Name	Length	C	R	W	T	U	I
10	Control value (PWM)	Output A	1 Byte	C	-	W	-	-	
11	Trigger valve purge	Output A	1 bit	C	-	W	-	-	
12	Status valve purge	Output A	1 bit	C	-	-	T	-	
13	RTR fault	Output A	1 bit	C	-	-	T	-	
14	Forced operation	Output A	1 bit	C	-	W	-	-	
15	Status heating	Output A	1 bit	C	-	-	T	-	
25	Contact monitoring	Output A	1 bit	C	-	-	T	-	
26	Current Value	Output A	2 Byte	C	R	-	T	-	
27	Status Current-Threshold 1	Output A	1 bit	C	-	-	T	-	
28	Status Current-Threshold 2	Output A	1 bit	C	-	-	T	-	
29	Status Switch	Output A	1 bit	C	R	-	T	-	

# ABB i-bus<sup>®</sup> KNX Commissioning

No.	Function	Object name	Data type	Flags
<b>10</b>	<b>switch</b>	<b>Output A</b>	<b>EIS 1, 1 bit DPT 1.001</b>	<b>C, W</b>
<p>This communication object is visible if control of the heating actuator is implemented via a 1 bit communication object. The heating valve is controlled directly using it. The device receives a switch telegram via the Switch object.</p> <p>N/O: Telegram value    1 = valve open                          0 = valve closed</p> <p>N/C: Telegram value    1 = valve closed                          0 = valve open</p>				
<b>10</b>	<b>Control value (PWM)</b>	<b>Output A</b>	<b>EIS 6, 1 byte DPT 5.010</b>	<b>C, W</b>
<p>This communication object is visible if the control of the heating actuator is implemented via a 1 byte communication object, e.g. within a continuous control. The communication object value [0...255] is determined by the variable mark-to-space ratio of the valve.</p> <p>Telegram value    1 = valve closed                          0 = valve open</p>				
<b>11</b>	<b>Trigger valve purge</b>	<b>Output A</b>	<b>EIS 1, 1 bit DPT 1.001</b>	<b>C, W</b>
<p>This communication object is enabled if the <i>yes</i> option is selected for parameter <i>Enable function "valve purge"</i> in the <i>A: Function</i> parameter window.</p> <p>The valve purge is triggered using this communication object.</p> <p>Telegram value:    0 = end valve purge, valve will be closed                          1 = start valve purge, valve will be opened</p>				

# ABB i-bus<sup>®</sup> KNX Commissioning

No.	Function	Object name	Data type	Flags
12	Status valve purge	Output A	EIS 1, 1 bit DPT 1.002	C, T
<p>This communication object is enabled if the yes option is selected for parameter <i>Enable function "valve purge"</i> in the <i>A: Function</i> parameter window.</p> <p>The status of the valve purge is visible via this communication object.</p> <p>Telegram value:   0 = valve purge not active                       1 = valve purge active</p> <div style="border: 1px solid black; padding: 5px; margin: 10px 0;"> <p><b>Please note</b></p> <p>The status is displayed as soon as a purge has been activated. The status remains active even when the purge has been interrupted, e.g. by a priority.</p> </div>				
13	RTR fault	Output A	EIS 1, 1 bit DPT 1.005	C, T
<p>This communication object is enabled if the yes option is selected for parameter <i>Enable monitoring of the controller</i> in the <i>A: Function</i> parameter window.</p> <p>Using this communication object, communication objects <i>Switch</i> and <i>Control value (PWM)</i> can be cyclically monitored. If the room thermostat (RTR) values are missing, the device assumes that the thermostat is malfunctioning and signals a fault.</p> <p>Telegram value:   1 = fault                       0 = no fault</p>				
14	Forced operation	Output A	1 bit (EIS 1) DPT 1.003	C, W
<p>This communication object is enabled if the yes option is selected for parameter <i>Enable function "forced operation"</i> in the <i>A: Function</i> parameter window.</p> <p>If the communication object receives the value 1, the valve is forcibly moved to the parameterized position set in parameter window <i>A: Forced Operation</i>. The forced positioning of the valve continues until forced operation is ended, which happens when a telegram with value 0 is received via communication object <i>Forced operation</i>.</p> <p>Please note that the <i>Forced operation</i> function and a bus voltage failure have a higher priority on the contact position, see <a href="#">Function diagram</a>, p. 147.</p>				
15	Status heating	Output A	EIS 6, 1 byte DPT 5.010	C, W
<p>This communication object is visible if control of the heating actuator is implemented via a 1 bit communication object, e.g. within a continuous control, and feedback of the control value is parameterized with a 1 byte value.</p> <p>The current 1 byte control value of the output is sent via this communication object.</p>				

# ABB i-bus<sup>®</sup> KNX Commissioning

No.	Function	Object name	Data type	Flags
15	<b>Status heating</b>	<b>Output A</b>	<b>EIS 1, 1 bit DPT 1.001</b>	<b>C, T</b>
<p>This communication object is visible if control of the heating actuator is implemented via a 1 bit communication object, e.g. within a continuous control, and feedback of the control value is also parameterized with a 1 bit value. The current 1 bit control value of the output is sent via this communication object when there is a change. With selection of the option <i>0% = "0" otherwise "1"</i>, the following applies:</p> <p>Telegram value:    1 = control value is not equal to 0 %                           0 = control value is equal to 0 %</p> <p>Telegram value:    1 = control value is equal to 0 %                           0 = control value is not equal to 0 %</p>				
16... 24				
Not assigned				
25	<b>Contact monitoring</b>	<b>Output A</b>	<b>EIS 1, 1 bit DPT 1.002</b>	<b>C, T</b>
<p>This communication object is enabled if the <i>yes</i> option is selected for parameter <i>Enable function "current detection"</i> in the <i>A: Function</i> parameter window. The communication object value shows the contact state when the contact is open. Should a current flow be detected on a contact opened via KNX, contact welding or manual switch on has occurred (contact fault). Evaluation of whether a current is flowing occurs about one second after a contact is opened. Current will definitely be detected if a measurable current (about 20 mA) is flowing. A KNX switch operation is required for evaluation to work properly.</p> <p>Telegram value    1 = contact error                           0 = no current is flowing</p>				
26	<b>Current Value</b>	<b>Output A</b>	<b>EIS 10, 2 byte DPT 7.012</b>	<b>C, R, T</b>
<p>This communication object is enabled if the <i>yes</i> option has been selected for parameter <i>Enable function "current detection"</i> in the <i>A: Function</i> parameter window and the 2 byte datapoint type has been selected in the <i>A: Current Detection</i> parameter window. The presently detected current is transferred via KNX; 1 digit corresponds to 1 mA. <b>For further information see: <a href="#">Current detection specifications</a>, p. 44</b></p>				
26	<b>Current Value</b>	<b>Output A</b>	<b>EIS 9, 4 byte DPT 14.019</b>	<b>C, R, T</b>
<p>This communication object is enabled if the <i>yes</i> option has been selected for parameter <i>Enable function "current detection"</i> in the <i>A: Function</i> parameter window and the 4 byte datapoint type has been selected in the <i>A: Current Detection</i> parameter window. The current value is transferred via KNX as a mA value. <b>For further information see: <a href="#">Current detection specifications</a>, p. 44</b></p>				

# ABB i-bus<sup>®</sup> KNX Commissioning

No.	Function	Object name	Data type	Flags
27	Status Current-Threshold 1	Output A	EIS 1, 1 bit DPT 1.002	C, T
<p>This communication object is enabled if the <i>yes</i> option is selected for parameter <i>Enable current threshold value(s)</i> in the <i>A: Current Detection</i> parameter window.</p> <p>The status of current threshold 1 is only sent when a change occurs.</p> <p>The status value can be inverted.</p> <p>Telegram value     1 = threshold value 1 plus threshold value 1 hysteresis is exceeded                                  0 = threshold value 1 minus threshold value 1 hysteresis is not exceeded</p> <p><b>For further information see: <a href="#">Threshold function with current detection</a>, p. 142</b></p>				
28	Status Current-Threshold 2	Output A	EIS 1, 1 bit DPT 1.002	C, T
<p>This communication object is enabled if the <i>yes</i> option is selected for parameters <i>Enable current threshold value(s)</i> and <i>Enable threshold value 2</i> in the <i>A: Current Detection</i> parameter window.</p> <p>The status of current threshold 1 is only sent when a change occurs.</p> <p>The status value can be inverted.</p> <p>Telegram value     1 = threshold value 2 plus threshold value 2 hysteresis is exceeded                                  0 = threshold value 2 minus threshold value 2 hysteresis is not exceeded</p> <p><b>For further information see: <a href="#">Threshold function with current detection</a>, p. 142</b></p>				
29	Status Switch	Output A	EIS 1, 1 bit DPT 1.001	C, R, T
<p>This communication object is enabled if the options <i>only after changing</i> or <i>always</i> are selected for parameter <i>Status response of switching state Object "Status Switch"</i> in parameter window <i>A: General</i>.</p> <p>The communication object value directly indicates the current contact position of the switching relay.</p> <p>The status value can be inverted.</p> <p>Telegram value     1 = relay ON or OFF depending on the parameterization                                  0 = Relay OFF or ON depending on the parameterization</p>				



### 4 Planning and application

In this section you will find some tips and application examples for practical use of ABB i-bus<sup>®</sup> Switch Actuators.

#### 4.1 Current detection

The current detection feature opens many new fields of application for the Switch Actuators. The following list contains a few examples:

- Load current detection (from 20 mA)
- Detection of significant equipment failure
- Preventative detection of failures by continuous current monitoring
- Recording actual operating hours
- Signaling of maintenance and service work
- Detection of open circuits
- Recording switch operations per period
- Energy and load management
- Monitoring and signaling

##### Please note

Only load currents with a sine wave characteristic can be detected correctly. For other signal types, e.g. phase angle or inverse phase angle control signals, the detected current value is distorted. In this case, the measured value is meaningless.

Current values less than 20 mA are indicated as a 0 mA value via KNX. For small load currents that are just above the minimum detection threshold of 20 mA a value of 0 mA could be displayed due to inaccuracies even though a current is flowing.

The current detection and monitoring function should not be used for safety-related applications. The Switch Actuator cannot assume the function of a circuit-breaker or RCD (earth-leakage circuit breaker).

If the load current detection is used for equipment fault detection that only causes a slight change of less than 30 mA, then mains voltage and current fluctuations due to ambient influences, e.g. temperature and natural ageing of the device play a significant role. Even when current changes are detected by the Switch Actuator, the detected changes do not necessarily mean that a device has malfunctioned.

Below are some current detection application examples described in more detail.

## 4.1.1 Threshold function with current detection

The current detection function features two independent thresholds.

The detected current value will fluctuate by about 20 mA due to the necessary analog/digital conversion of the detected load current. To avoid a continuous change of the threshold value state, the thresholds for current recognition feature a hysteresis function. The width of the hysteresis band is determined by the parameterizable hysteresis threshold.

### Example

Hysteresis curve, parameterization: *overshoot 1 – undershoot 0*

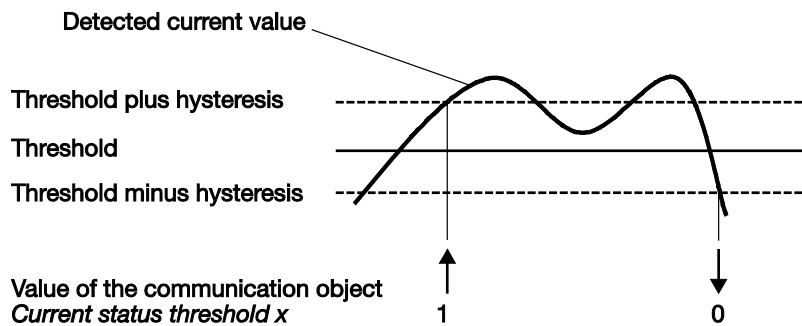

Should the upper hysteresis threshold be overshoot or the lower hysteresis threshold undershot, the value of communication object *Status Current-Threshold x* is modified and sent via the bus.



# ABB i-bus<sup>®</sup> KNX Planning and application

## 4.1.2 Operating state displays

A Switch Actuator with current detection is designed for recording and displaying operating states of electrical loads.

The operating state is detected indirectly via the load current. If the load current exceeds a threshold, an ON telegram is sent via the bus, if the value drops below the threshold, an OFF telegram is issued. This ON/OFF telegram can be received for example by a Universal Concentrator and displayed on the display panel.

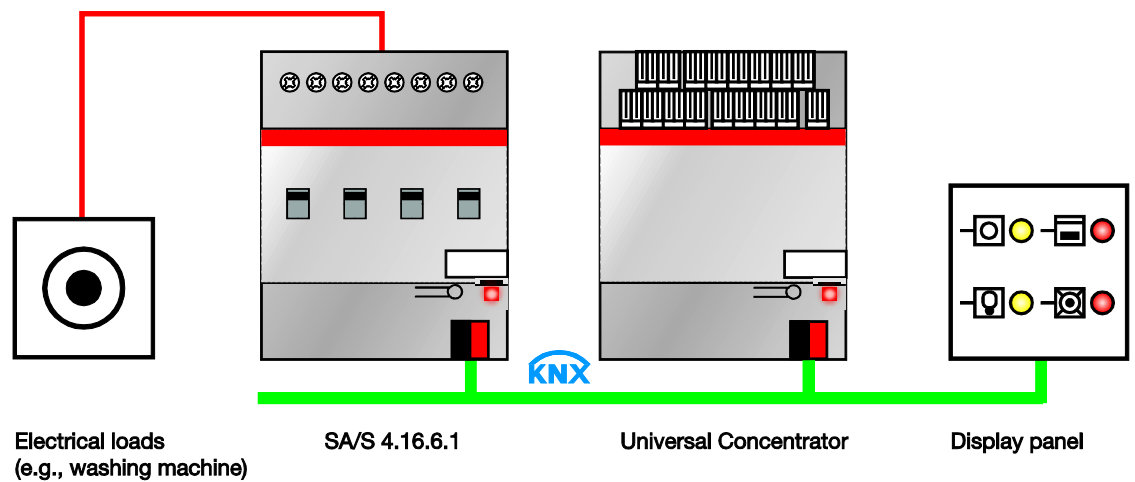

# ABB i-bus<sup>®</sup> KNX Planning and application

## 4.1.3 Recording operating hours

With the help of current detection in the Switch Actuator and a separate meter or counter element, it is possible to record, signal and display the actual electrical operating hours of electrical loads. This function can be used in facility management or for preventative maintenance and service planning. Filter exchange in air-conditioning systems or the replacement of lamps can be optimized and planned in advance.

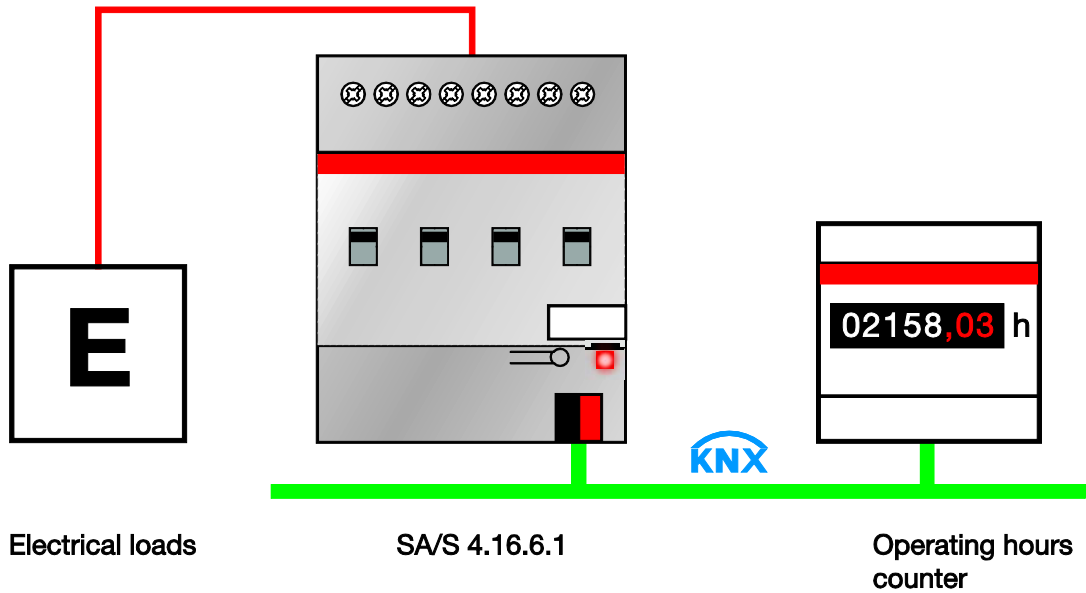

# ABB i-bus<sup>®</sup> KNX Planning and application

## 4.1.4

### Trend analysis

Trend analysis is used to monitor the states of electrical systems over long periods and to receive early warnings of possible defects. The system operator can use this information for planning and carrying out inspections, and undertake repairs before the system fails.

#### Example

Should the current value change, telegrams are sent via the bus. These telegrams can be evaluated on a PC and displayed as a diagram using visualization software. Thus, changes which occur over an extended period are easily recognizable. If trend analysis is combined with logging, a defective device can be quickly and easily identified before it fails.

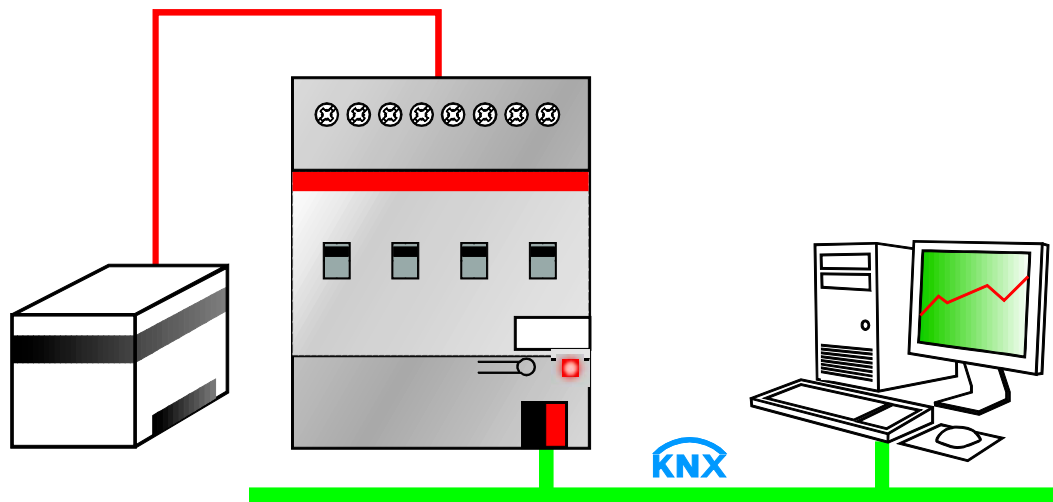

Electrical system  
(e.g., computer system)

SA/S 4.16.6.1

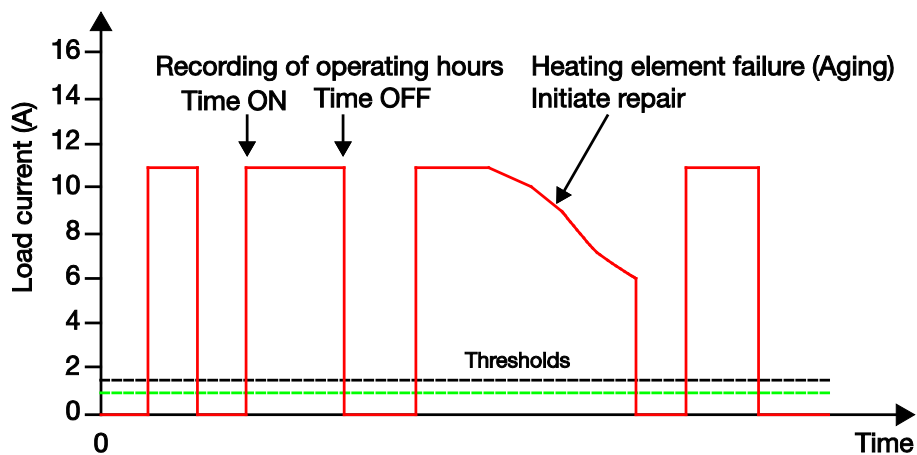

# ABB i-bus<sup>®</sup> KNX Planning and application

## Current display

The Switch Actuators with current detection are not current measurement display devices. The detected current and its tolerances (see [Technical data](#), from p. 9), can be displayed.

Using the KNX, this current value can be sent to a complex maintenance center or a simple LCD display or visualization, e.g. a panel. Further processing or display is possible from here. This makes real-time monitoring or facility management of the installation possible.

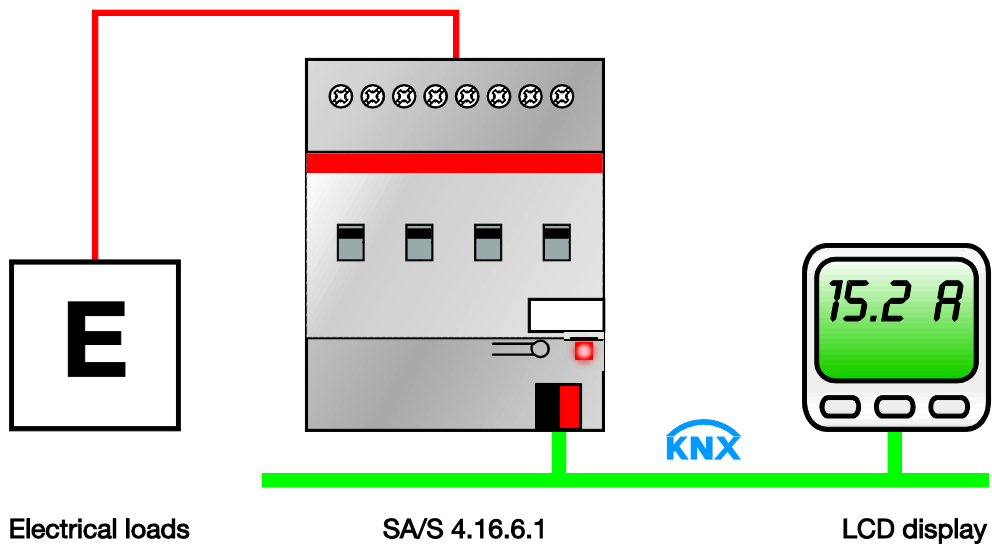

# ABB i-bus<sup>®</sup> KNX Planning and application

## 4.2 Operating mode *Switch Actuator*

### 4.2.1 Function diagram

The following illustration indicates the sequence in which the functions are processed. Communication objects which lead to the same box have the same priority and are processed in the sequence in which the telegrams are received.

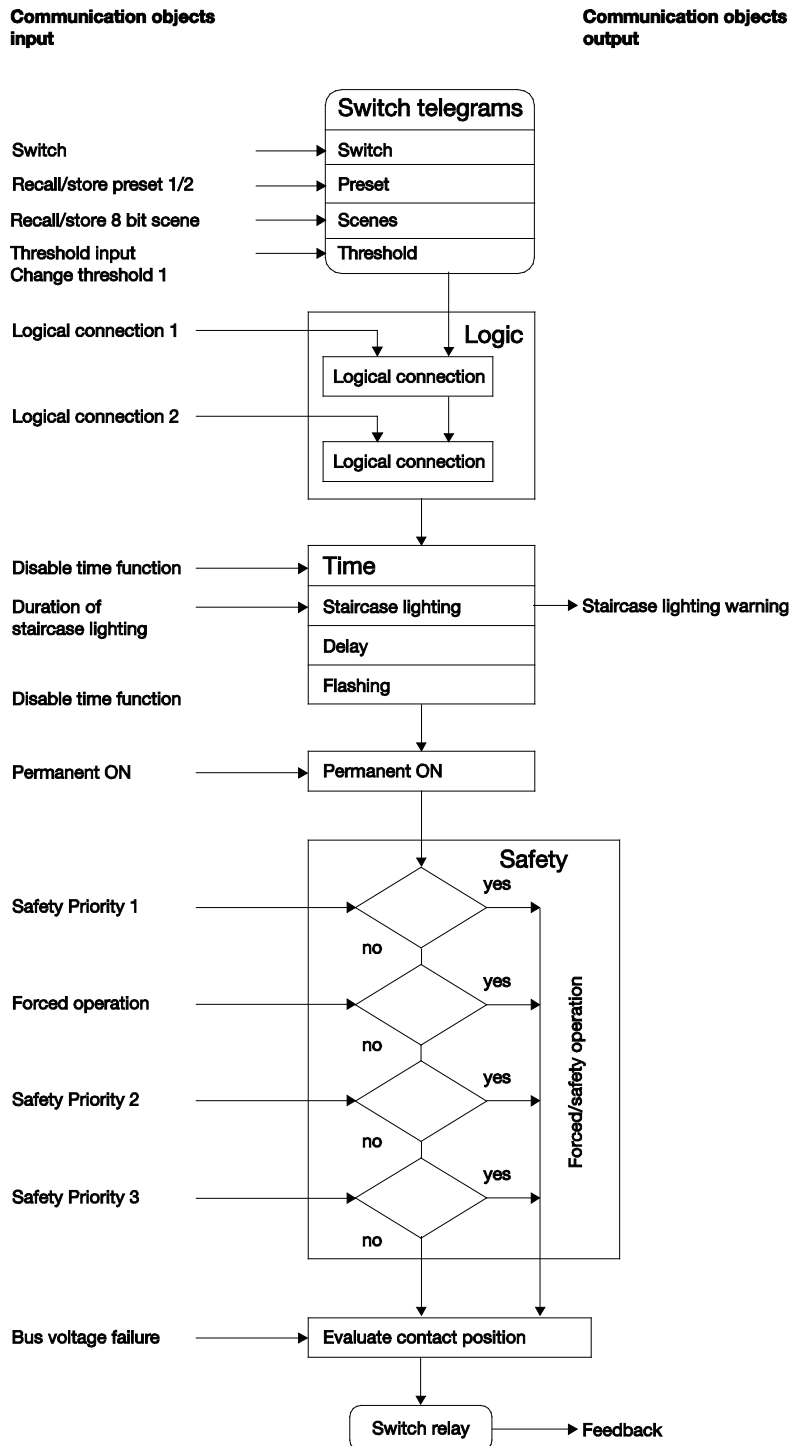

### Example

If both communication objects *Logical connection x* are activated, a telegram received via communication object *Switch* is connected to them. The result of this action serves as the input signal for the Time function. If this is not disabled, a corresponding switch signal is generated, e.g. delay or flashing. Before the switch telegram reaches the relay, communication objects *Safety Priority x* and *Forced operation* are checked and undertaken, if required, as a priority. Subsequently, the switching action is only dependent on the state of the bus voltage. The relay is switched if a switching action allows it.

### 4.2.2 Time function

The Time function can be enabled (value 0) and disabled (value 1) via the bus (1 bit communication object *Disable time function*). The output operates without a delay as long as the *Time* function is disabled.

Various functions can be undertaken using the Time function:

- Staircase lighting
- ON/OFF delay
- Flashing

#### 4.2.2.1 Staircase lighting

After the staircase lighting time  $T_{ON}$  has elapsed, the output switches off automatically. For every telegram with the value 1 the time restarts (*retrigger function*), if the parameter *Extending staircase lighting by multiple operation ("pumping up")* in [Parameter window A: Time](#), p. 76 is set to *no*, *no pump up possible*.

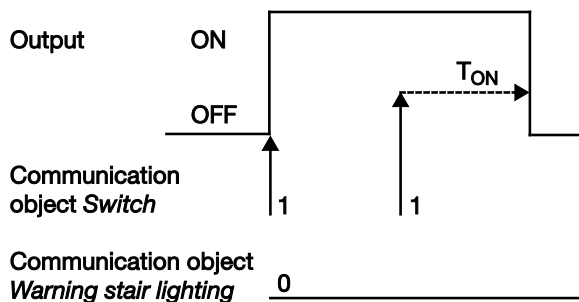

This corresponds with the basic response of the Staircase lighting function as long as a warning is not parameterized.

# ABB i-bus<sup>®</sup> KNX Planning and application

## Warning

The additional Warning function enables the user to be warned in good time before the staircase lighting time elapses. The warning can be carried out by switching the output on/off briefly or by sending a communication object.

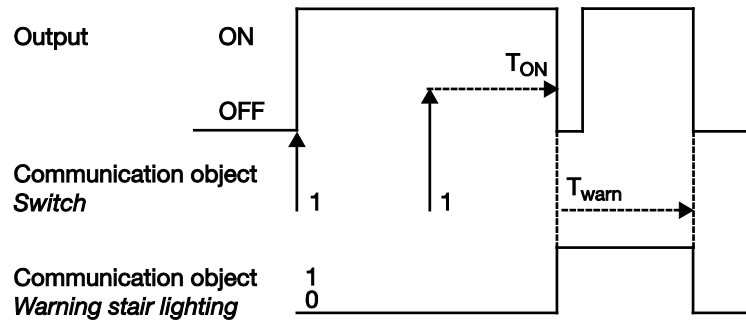

The warning time  $T_{WARN}$  extends the ON phase. At the start of the warning time, the output can be briefly switched on and off and/or the communication object *warning stair lighting* can be written with the value 1. After the staircase lighting time  $T_{ON}$  elapses, the output is switched off briefly for the  $T_{WARN}$  period and communication object *warning stair lighting* sends a telegram. As a result, for example, half of the lighting is switched off or an LED is switched on as a warning.

The entire staircase lighting time during which the lighting is on corresponds with the time period  $T_{ON}$  plus  $T_{WARN}$ .

# ABB i-bus<sup>®</sup> KNX

## Planning and application

### Retriggering

Via “pumping up” – actuation of the push button several times in succession – the user can adapt the staircase lighting to current needs. The maximum duration of the staircase lighting time can be set in the parameters.

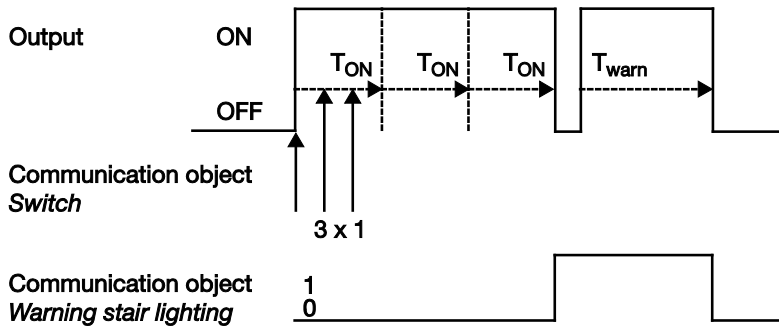

If the device receives a further ON telegram when the staircase lighting is switched on, the staircase lighting time is added to the remaining period.

The warning time does not change due to “pumping up” and is added to the extended (x-fold  $T_{ON}$ ) ON time.

#### Application examples

- Lighting control in stairwells
- Monitoring of telegrams



# ABB i-bus<sup>®</sup> KNX Planning and application

## 4.2.2.2

### ON/OFF delay

The ON/OFF delay delays output switch-on or switch-off.

#### Example 1:

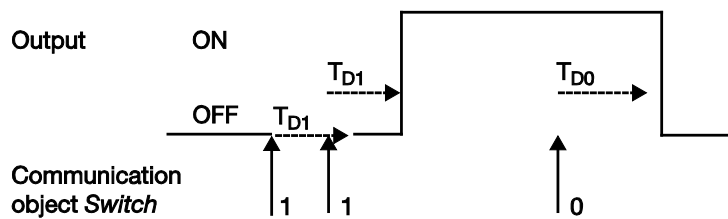

#### Example 2:

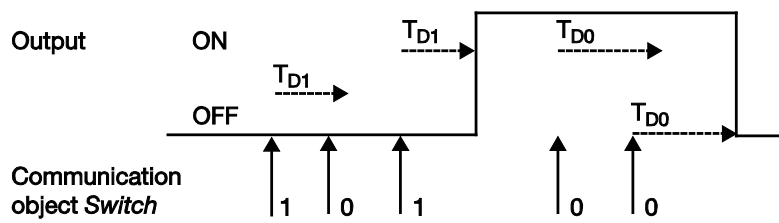

The delay time  $T_{D1}$  or  $T_{D0}$  starts after a switch telegram, and after it has elapsed, the output executes the switch telegram.

If a new ON telegram with the value 1 is received during the switching ON delay, the ON delay time starts again. Likewise, if a new OFF telegram with the value 0 is received during the switching OFF delay, the OFF delay time starts again.

#### Please note

If the device receives an OFF telegram during the switching on delay time  $T_{D1}$ , an ON telegram is disregarded.

# ABB i-bus<sup>®</sup> KNX Planning and application

## 4.2.2.3 Flashing

The output can flash, i.e. switch on and off periodically.

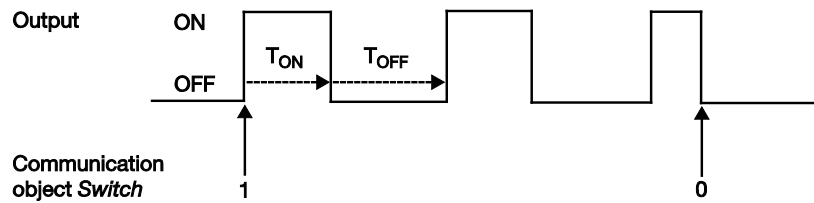

The switch on time ( $T_{ON}$ ) and switch off time ( $T_{OFF}$ ) during flashing can be parameterized.

### Please note

The contact life of the contacts should be considered and can be found in the technical data. Limiting the number of switching operations with the parameter *Number of ON impulses* may be useful. Furthermore, a delay in the switching sequence may possibly be caused by the limited availability of switching energy with very frequent switching. The possible number of switching operations should be considered. Refer to the technical data in section 2.

# ABB i-bus<sup>®</sup> KNX Planning and application

## 4.2.3 Logic function

With the Logic function it is possible to connect the switching of the output with certain conditions.

Two connection objects are available:

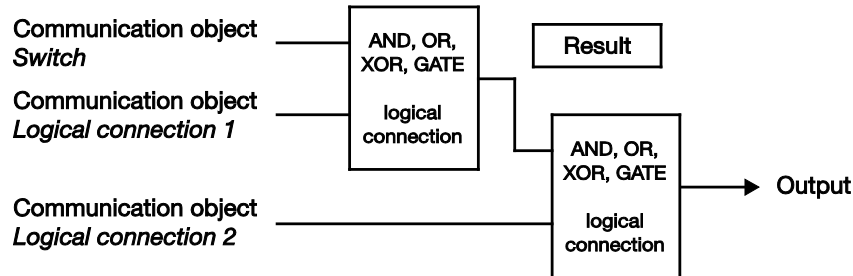

Initially the communication object *Switch* is evaluated with communication object *Logical connection 1*. The result is then linked with communication object *Logical connection 2*.

The following Logic functions are possible:

Logical function	Object values					Explanations
	Switch	Connection 1	Result	Connection 2	Output	
<b>AND</b>	0	0	0	0	0	The result is 1 if both input values are 1. The output is 1 if both input values are 1.
	0	1	0	1	0	
	1	0	0	0	0	
	1	1	1	1	1	
<b>OR</b>	0	0	0	0	0	The result is 1 if one of the input values is 1.
	0	1	1	1	1	
	1	0	1	0	1	
	1	1	1	1	1	
<b>XOR</b>	0	0	0	0	0	The result is 1 when both input values have a different value.
	0	1	1	1	0	
	1	0	1	0	1	
	1	1	0	1	1	
<b>GATE</b>	0	disabled	–	disabled	–	The communication object <i>Switch</i> is only allowed through if the GATE (connection) is open. Otherwise, receipt of communication object <i>Switch</i> is ignored.
	0	enabled	0	enabled	0	
	1	disabled	–	disabled	–	
	1	enabled	1	enabled	1	

The Logic function is always re-calculated when an object value is received.

### Example GATE function

- The GATE connection is set to disable as soon as the communication object *Logical connection x* receives a 0.
- The communication object *Logical connection 1* receives a 0, i.e. the GATE is disabled.
- The output of the logical connection is 0.
- The communication object *Switch* receives 0, 1, 0, 1. The output of the logic operation always remains 0.
- The communication object *Logical connection x* receives a 1, i.e. the GATE is enabled. The enabling condition (value 0 or 1) can be parameterized.
- However, the output of the logical connection is not recalculated.

### Please note

The values of communication objects *Logical connection 1/2* and *Switch* can be parameterized on bus voltage recovery.  
If values are not assigned for communication objects *Logical Connection 1/2*, they will be deactivated.  
On reset via the bus, the values of communication objects *Logical Connection 1/2* remain unchanged.

### Please note

With the SA/S x.x.x.1 the current switch status is also sent via the communication object *Status Switch* if a telegram is received via communication object *Logical connection x*. The prerequisite is that the send reaction of the switch status (see parameter window [Parameter window A: General](#), p. 66) is set to *always*.

This is not the case with the SA/S x.6.1, SA/S x.10.1 and SA/S x.16.1. The switch status is only sent if a telegram is received on the communication object *Switch*.

# ABB i-bus<sup>®</sup> KNX Planning and application

## 4.2.4

### Preset function

A parameterizable contact position can be retrieved with the help of presets. Light scenes can therefore be implemented for example with a 1 bit communication object.

#### Call preset

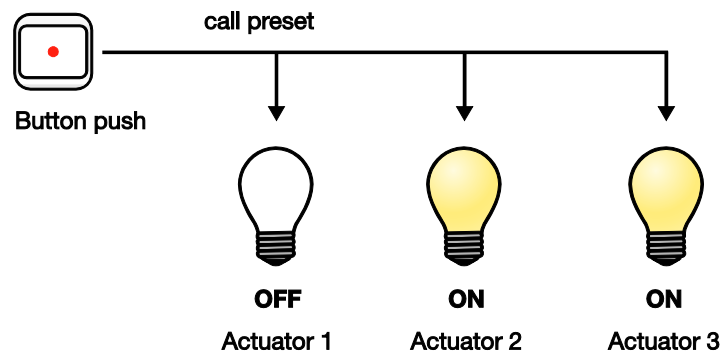

Contact positions (preset values) can be recalled via communication objects *Call preset 1/2*. A maximum of two preset values are available for each output:

Action	Telegram
Recall preset 1	Communication object Call preset 1/2 = 0
Recall preset 2	Communication object Call preset 1/2 = 1

#### Set preset

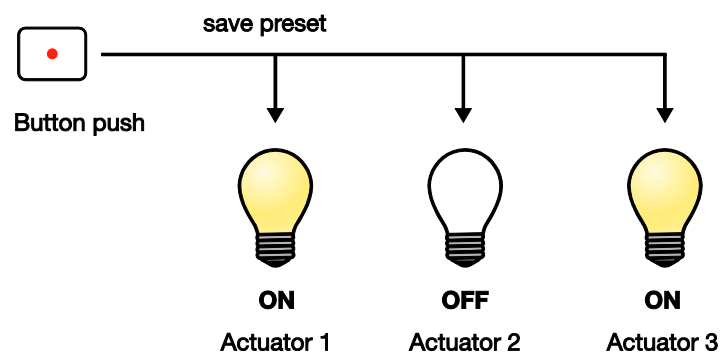

The current contact position is stored as a new preset value via the communication object *Set preset 1/2*. The user can, for example, adapt a light scene in this way. The presets are stored via the following values:

Action	Telegram
Store preset 1	Communication object Set preset 1/2 = 0
Store preset 2	Communication object Set preset 1/2 = 1

# ABB i-bus<sup>®</sup> KNX

## Planning and application

### Special function: Restore state

A useful special function can be assigned to preset 1. It is possible to recreate the brightness levels (states) which were present before recalling preset 2.

The following diagram clarifies this:

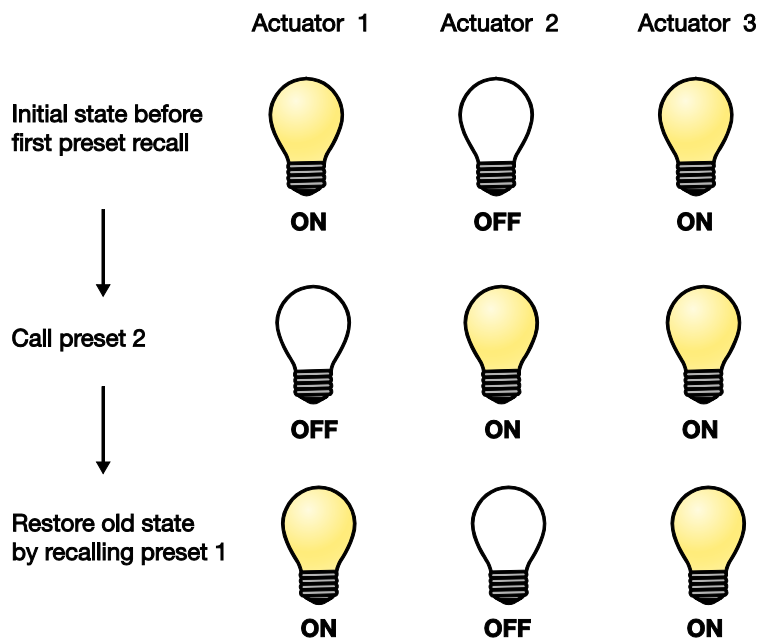

This function can be used for example after a presentation to restore the lighting to the state it was in beforehand.

### 4.2.5

### Scene function

With the 8 bit scene function, the push button issues the switch actuator with the instruction to recall a scene. The scene is not stored in the push button but rather in the switch actuator. All switch actuators belong to the same group address. A single telegram is thus sufficient to recall the scene.

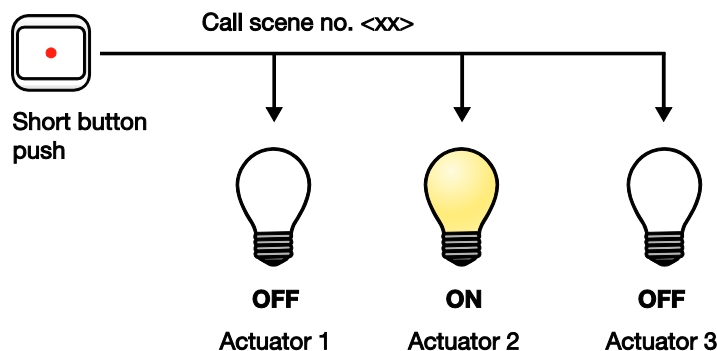

Along with the telegram value a scene number is sent which must correspond with the scene number in the parameters of the Switch Actuator.

# ABB i-bus<sup>®</sup> KNX

## Planning and application

Up to 64 different scenes are managed via a single group address. The scene telegram contains the recall or store functions of a scene.

The scene function which controls multiple KNX devices is described below.

With Scene it is possible to retrieve one of 64 scenes or to connect multiple KNX devices in a scene. The scene can be retrieved or stored using a single telegram. It is a prerequisite that all the operating devices are parameterized with the same scene number.

Each KNX device involved receives the scene telegram and independently controls the scene values. Via the Switch Actuator, for example, the outputs are switched on or off, the blind actuator moves the blind to a defined position, and the DALI gateway dims its output to the pre-programmed brightness values.

Up to 64 different scenes can be managed via a single KNX group address. The following information is contained in a scene telegram:

- Number of the scene (1...64)
- Recall scene / store scene

For further information see: [Code table, 8 bit scene](#), p. 171

Benefits
The <i>Scene</i> function on ABB i-bus <sup>®</sup> devices offers the following decisive advantage: All settings to be undertaken in a scene are stored in the device. Therefore, they need not be sent via KNX with a scene recall – all that is required is a numeric value which has been assigned to the scene. This considerably reduces the load on the bus and prevents unnecessary telegram traffic via KNX.

A typical *Scene* function might be as follows and is described using the 8 bit scene telegram as an example:

The task is to implement the room lighting for a presentation with ABB i-bus<sup>®</sup> devices. The following devices are used in the room:

- Switch actuator for the basis lighting
- Blind actuator for shading
- DG/S (DALI Gateway) for dimmable lighting
- 1-10 V light controller for brightness detection and constant lighting control

# ABB i-bus<sup>®</sup> KNX Planning and application

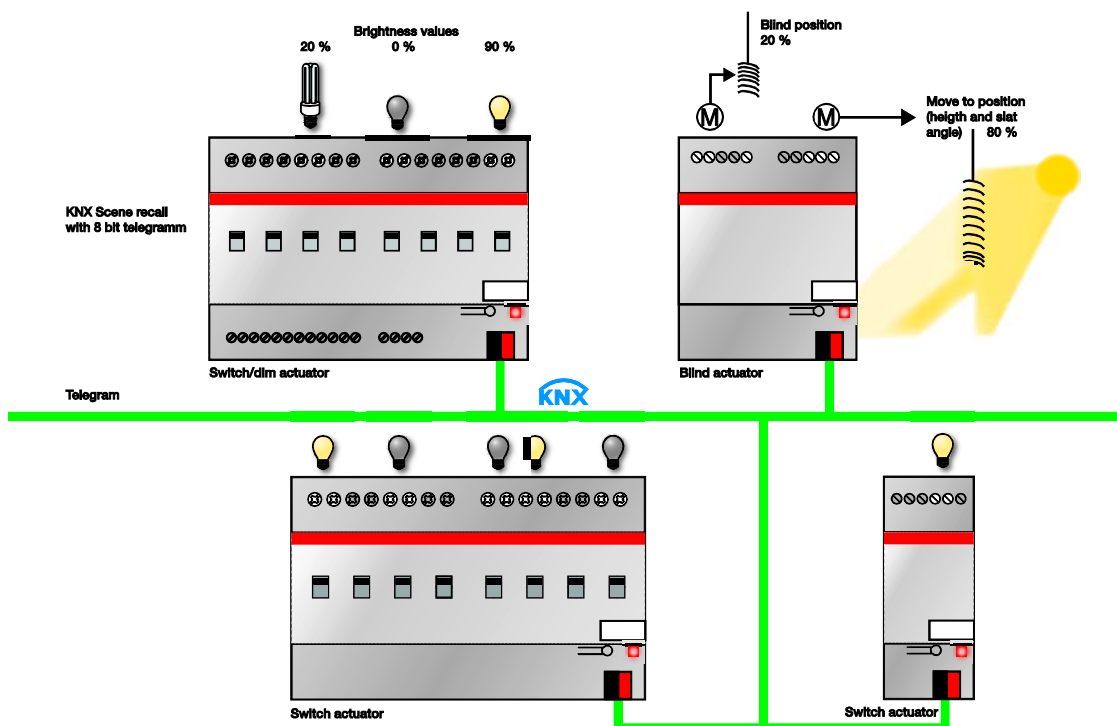

## Example

An 8 bit scene (no. 8) comprises some lamps which are connected to two Switch Actuators and a light controller output.

Also, two blinds are integrated into the *Scene* function via a blind actuator. The *Scene* can be recalled via a single KNX telegram. The prerequisite for this is that all slaves have Scene 8 set in their devices. After a telegram has been received, the slaves switch on their *Scene* number 8. The blind actuator moves the blinds to the corresponding position; the lighting assumes the predefined brightness values and contact positions defined by the *Scene*.

## Please note

The scene numbering 1 to 64 is recalled via KNX using a telegram value 0 to 63. For corresponding scene coding see [Code table, 8 bit scene](#), p. 171.



# ABB i-bus<sup>®</sup> KNX Planning and application

## 4.2.6 Threshold function

The Threshold function monitors a 1 or 2 byte value. As soon as a threshold is undershot or overshot, the output can be switched. The threshold values can be interpreted as hysteresis values:

### Threshold values are hysteresis values

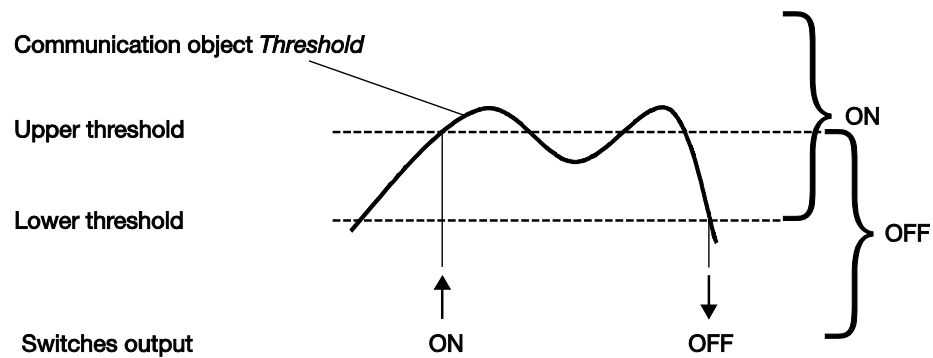

When the value exceeds the upper threshold or falls below the lower threshold, the output is switched.

#### Please note

If the communication object *Threshold* receives a value that does not overshoot or undershoot the old value, no switching action is triggered.

During the Threshold function the Switch Actuator can continue to receive telegrams that can trigger switching actions.

The communication object *Switch* and the functions Scene, Preset and Threshold have the same priority and are processed in the order that the telegram is received.

# ABB i-bus<sup>®</sup> KNX Planning and application

Threshold values are not hysteresis values

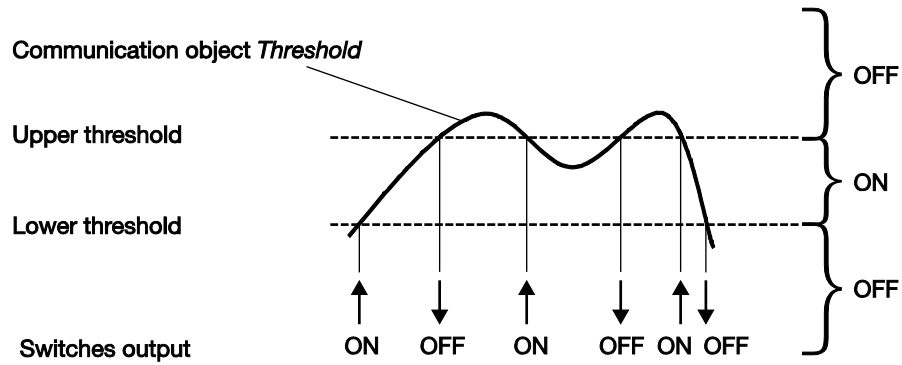

The output is switched when any threshold is undershot or overshot.

**Please note**

If the communication object *Threshold* receives a value that does not overshoot or undershoot the old value, no switching action is triggered.

# ABB i-bus<sup>®</sup> KNX Planning and application

## 4.3 Operating mode *Heating Actuator*

### 4.3.1 Function diagram

The following illustration indicates the sequence in which the functions are processed:

**Communication objects  
input**

**Communication objects  
output**

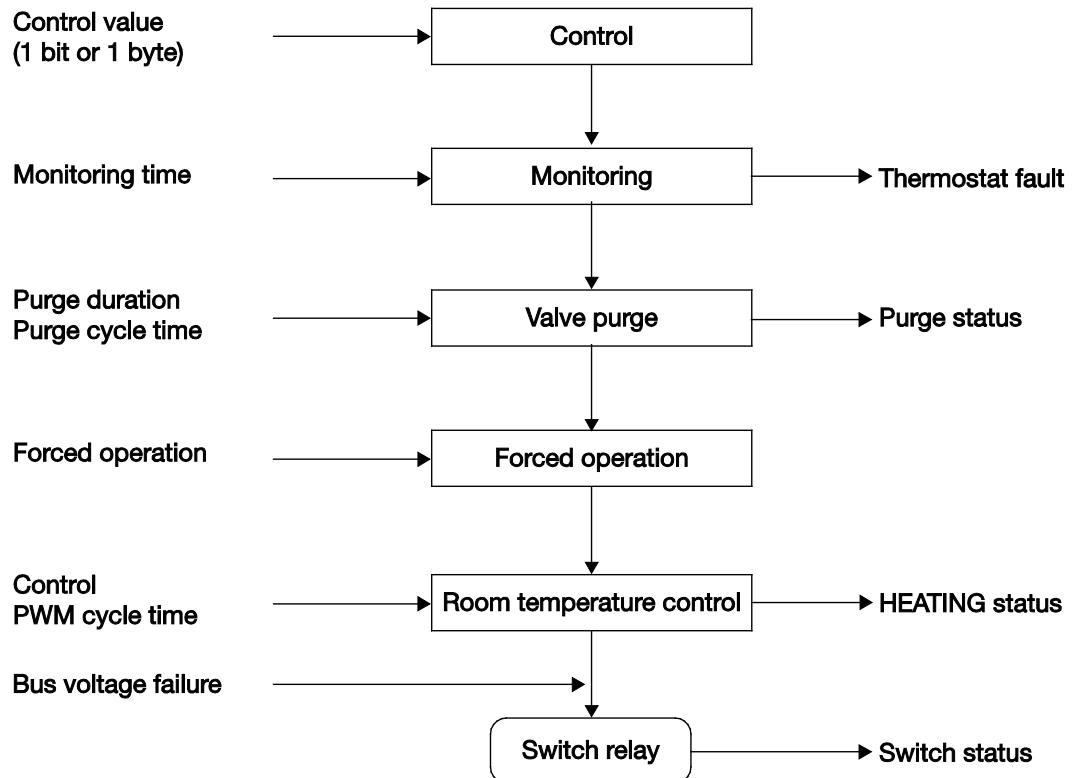

## 4.3.2 2-step control

2-step control is the simplest form of control. No control value is calculated here. The room thermostat sends a 1 via the communication object *Switch* if a certain temperature is exceeded and a 0 if the value drops below a certain temperature. These switch values are implemented by the SA/S.

The room thermostat hysteresis limits can be used for control stability. Use of these limits does not affect the method of operation of the Switch Actuator.

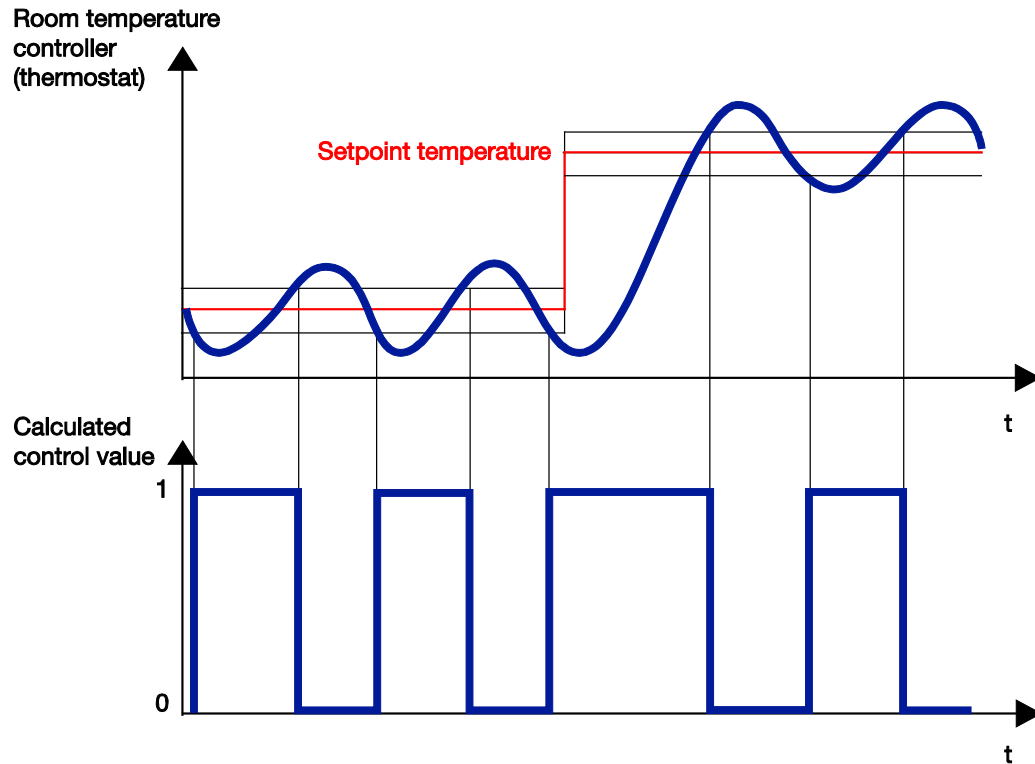

A room thermostat can use the control algorithm of a PWM control. As the room thermostat sends ON and OFF telegrams to the SA/S, the actuator operates like a 2-step control.

# ABB i-bus<sup>®</sup> KNX Planning and application

## 4.3.3 Pulse width modulation (PWM)

Should the SA/S receive a 1 byte control value as an input signal, it can use this value with the parameterized cycle time and undertake a PWM calculation.

With PWM control, the received control value [0...100 %] calculated in the control algorithm is converted to a pulse width modulation.

The conversion is based on a constant cycle time. For example, if the SA/S receives a control value of 20 %, then for a cycle time of 15 minutes the valve will be opened for three minutes (20 % of 15 minutes) and closed for 12 minutes (80 % of 15 minutes).

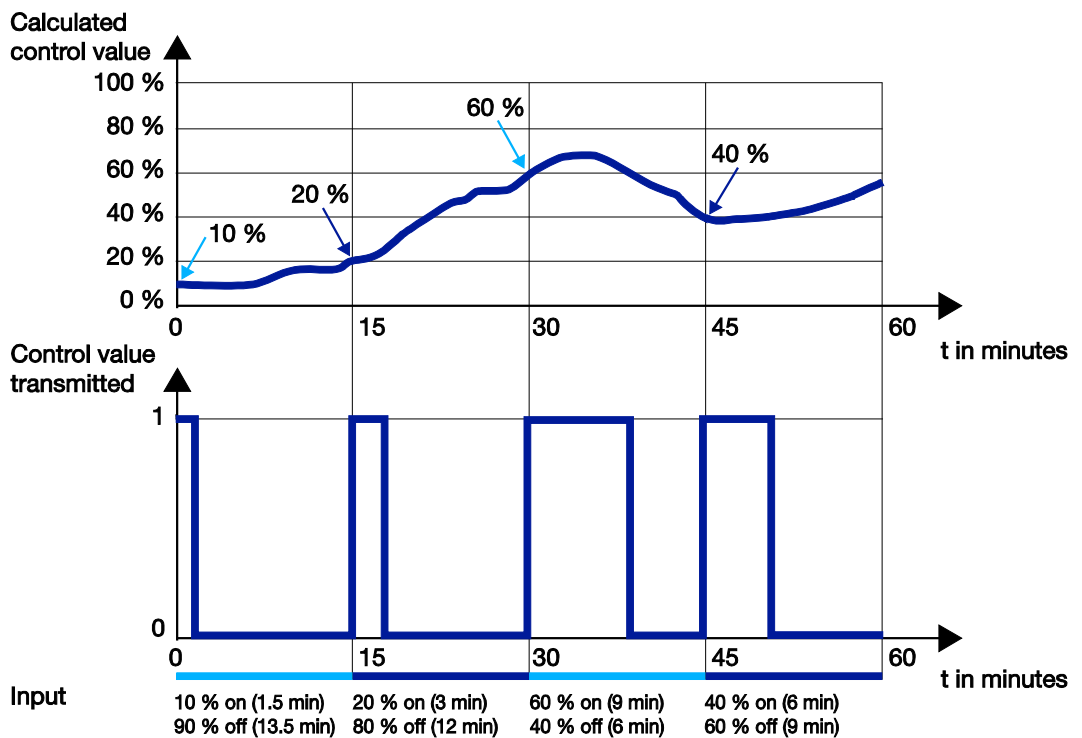

### 4.3.4 Pulse width modulation – calculation

With pulse width modulation, control is implemented by a variable mark-space ratio.

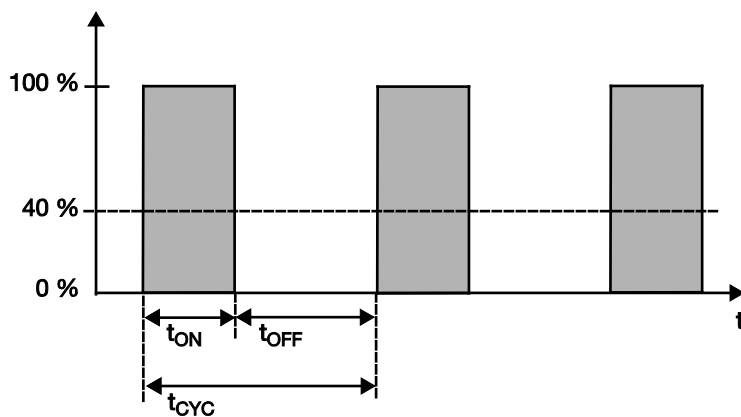

During the time  $t_{ON}$  the valve is opened, and during the time  $t_{OFF}$  it is closed. On account of  $t_{ON} = 0.4 \times t_{CYC}$  the valve is set to about 40 % on.  $t_{CYC}$  is the so-called PWM cycle time for continuous control.

#### Please note

Pulse width modulation leads to frequent switching of the outputs. The limited number of switching operations with normal Switch Actuators should be considered! Electronic Switch Actuators should preferably be used.

# ABB i-bus<sup>®</sup> KNX

## Planning and application

### 4.3.5 Lifetime examination of a PWM control

If a PWM cycle time of 15 minutes has been selected, this means that 4 switching operations (switching on/off) occur each hour, 96 in a day and 3,000 in a month. This amounts to 36,000 switching operations a year. With a relay life of  $10^5$  switching operations, this means a Switch Actuator life of less than three years.

However, if the cycle time is set too short, e.g. three minutes, this means about 150,000 switching operations annually. This in turn means the Switch Actuator life would be less than a year.

This observation assumes an AC1 switch load (almost exclusively resistive) at rated current. If the maximum number of switching operations for a purely mechanical relay load are assumed, the life of the Switch Actuator is extended. This has an inherent risk: the contact materials can wear prematurely and may not guarantee safe conduction.

Conventional cycle times for control of various heating and air-conditioning systems are listed below:

Heating system	Control type	Cycle time
Water heating Supply temperature 45...70 °C	PWM	15 minutes
Water heating Supply temperature < 45°C	2 step PWM	– 15 minutes
Underfloor/wall heating	PWM	20...30 minutes
Electrical underfloor heating	2 step	–
Electrical convection heating	PWM 2 step	10...15 minutes –

### 4.4 Reaction on bus voltage failure, recovery and download

#### Reaction on bus voltage failure

Response in the event of bus voltage failure is specified by the parameter *Reaction on bus voltage failure* in parameter window A: *General*. This parameterization acts directly on the relay and has the highest priority in the Switch Actuator.

For further information see: [Function diagram](#), p. 147 and [Function diagram](#), p. 161

Before the first switching action is possible after bus voltage recovery, the SA/S will first store enough energy to ensure enough is available to immediately bring all relays safely to the required (parameterized) contact position if there is another bus voltage failure.

If the setting is *Contact unchanged*, the relay contact position is also unchanged on bus voltage failure, i.e. with the staircase lighting function operational, this light remains on until bus voltage recovery and until a new switch action is received.

After the contact positions are set on bus voltage recovery, the Switch Actuator remains non-functional until the bus voltage recovers.

#### Reaction on bus voltage recovery

The Switch Actuator draws the energy for switching the contact from the bus. After bus voltage is applied, sufficient energy to switch all contacts simultaneously is only available, depending on SA/S type, after about 10...30 seconds, see [Technical data](#), from p. 9. Depending on the transmission and switching delay after recovery of bus voltage as set in the *General* parameter window, the individual outputs will only assume the contact positions that result from the function switching tree after this time. If a shorter time is set, the SA/S will only switch a contact when sufficient energy is stored in the SA/S to immediately bring all outputs safely to the required contact position if another bus voltage failure occurs.

The Switch Actuator starts operating again after about 1-2 seconds, regardless of the parameterized transmission and switching delay. This means the communication objects are set according to the programming, e.g. the timer for time delay is started. Switching or telegram transmission is only possible after the transmission and switch delay times have elapsed.

The threshold, scene and preset values set via KNX are still available after bus voltage recovery if the corresponding parameters for overwriting download are set to *no*. If parameterization is set to *yes*, the values set via the bus are overwritten with the values from ETS.



# ABB i-bus<sup>®</sup> KNX

## Planning and application

### Download:

During a download, the SA/S is not ready to function. No telegrams are received or sent and no switching actions are carried out. The primary objective is to ensure that a download has no effect on the operation of the device at the time. Accordingly, it is possible to perform a download during normal operation.

In parameter window A: *General* with the parameters *Overwrite scene, preset and threshold value 1 with download*, you can choose whether the scenes and preset values stored in the SA/S are retained or overwritten with the parameterized values with a download.

The following table lists the reaction of the Switch Actuator after bus voltage recovery, download and ETS bus reset are carried out:

Reaction on:	Bus voltage recovery	Download	ETS bus reset
Communication object values	Generally the communication object values can be parameterized. If not the communication object is written with 0.	Values are retained. Overwriting of the scene, preset and threshold 1 can be parameterized ( <i>X: General</i> ).	Values are retained including the scenes, preset values and threshold 1.
Timer	Out of operation.	Values are retained and out of operation.	As for download
Contact position	Initially unknown. Changes on receipt of new results based on the <a href="#">Function diagram</a> , p. 147. Execution after the transmission and switching delay times have elapsed (parameter window <i>General</i> ).	Unchanged. The contact position is re-calculated based on the object value only after an event is received and is set again if another contact position results. Exceptions are changes in forced operation and safety priorities. These changes are checked immediately and undertaken if necessary.	As for download

# ABB i-bus<sup>®</sup> KNX

## Planning and application

Reaction on:	Bus voltage recovery	Download	ETS bus reset
<b>Operating mode <i>Switch Actuator</i></b>			
<b>Switch object</b>	Parameterizable <sup>1)</sup> (Parameter window <i>X: General</i> )	Unchanged. Evaluation only after a new event has been received.	As for download
<b>Time function</b>	Enable can be parameterized (parameter window <i>X: Function</i> ), timer out of operation.	Unchanged, timer out of operation.	As for download
<b>Staircase lighting</b>	In the <i>X: Function</i> parameter window you can set whether or not the Time function is disabled after bus voltage recovery. Otherwise unchanged. Changes only after a new event has been received. The staircase lighting time as changed via the bus is lost, and replaced by the time which is parameterized in ETS.	Unchanged. Changes only after an event has been received. e.g. the staircase lighting remains on until it is started again or switched off	As for download
<b>Time delays</b>	Unchanged. Changes only after an event has been received.	Unchanged. Changes only after an event has been received.	As for download
<b>Flashing</b>	Unchanged. Changes only after an event has been received.	Unchanged. Changes only after an event has been received.	As for download
<b>Permanent ON</b>	Parameterizable (parameter window <i>X: Time</i> )	Unchanged	As for download
<b>Preset/scenes</b>	The preset and scene values stored in the SA/S are restored if the parameter for overwrite at download has been set to <i>yes</i> . When set to <i>no</i> , the values stored via KNX are retained.	Overwriting scene and preset values can be parameterized (parameter window <i>X: General</i> )	The stored preset and scene values in the SA/S are restored.
<b>Logic (Communication object <i>Logical connection x</i>)</b>	Can be parameterized (parameter window <i>X: Logic</i> ). Only evaluated after next event.	Only evaluated after next event.	As for download
<b>Threshold (communication object <i>Threshold input</i>)</b>	Can be parameterized (parameter window <i>X: Threshold</i> ). Only evaluated after next event.	Only evaluated after next event.	As for download

<sup>1)</sup> Before the very first download (device fresh from the factory), the value before bus voltage failure is not defined.  
For this reason, the communication object *Switch* is written with 0 and the contact is opened, even though the default setting is *not write*.

# ABB i-bus<sup>®</sup> KNX

## Planning and application

Reaction on:	Bus voltage recovery	Download	ETS bus reset
<b>Threshold</b> (communication object <i>Change Threshold value 1</i> )	Threshold value evaluation is carried out after bus voltage recovery using the parameterized threshold value, whereby the last status threshold detected in operation is used for comparison. Should no status threshold exist before bus voltage failure, the factory-set status (hysteresis limit undershoot) is assumed.  The thresholds currently saved in the SA/S are overwritten with the values parameterized in ETS if the overwrite with download parameter is set to <i>yes</i> . If set to <i>no</i> , the values stored via KNX are retained.	Overwrite Threshold 1 can be parameterized (parameter window <i>X: General</i> ).	The Threshold 1 stored in the SA/S will be restored.
<b>Safety priorities</b>	Inactive, communication object values are set to <i>inactive</i>	Communication object values are retained. Monitoring time is restarted.	As for download
<b>Forced operation</b>	Can be parameterized (Parameter window <i>A: Safety</i> )	Communication object values are retained. Monitoring time is restarted	As for download
<b>Current detection</b>	Current value is recalculated. Status Current-Threshold is calculated using this.	Current value is recalculated. Status Current-Threshold is calculated using this.	As for download
<b>Operating mode Heating Actuator</b>			
<b>Valve mode</b>	Position can be parameterized (Parameter window <i>X: General</i> )	Calculation (PWM) is continued.	As for download
<b>Function</b>	unchanged	Accepted if changed	Unchanged
<b>Monitoring</b> (Communication object <i>RTR fault</i> )	Monitoring time is restarted. Communication object value is 0.	Monitoring time is restarted. Communication object value is unchanged.	As for download
<b>Reaction on forced operation</b>	Off	unchanged	As for download
<b>Valve Purge</b>	Monitoring time restarts.	Monitoring time restarts.	As for download



## A Appendix

### A.1 Scope of delivery

ABB i-bus<sup>®</sup> KNX SA/S Switch Actuators are supplied together with the following components.

Please check the items received using the following list.

- 1 (one) SA/S x.y.z.w<sup>1)</sup>, MDRC
- 1 (one) set of installation and operating instructions
- 1 (one) bus connection terminal (red/black)

<sup>1)</sup>x = number of outputs (2, 4, 8 or 12)

y = rated current in Ampere (6 A, 10 A or 16 A)

z = device characteristic:

1 = standard device with normal switching capacity

5 = C-load device (200 µF) with increased switching capacity

6 = C-load device (200 µF) with increased switching capacity and current detection

w = hardware version

### A.2 Code table, 8 bit scene

The following table indicates the telegram code for an 8 bit scene in hexadecimal and binary code for the 64 scenes. Normally when retrieving or storing a scene, an 8 bit value must be sent.

# ABB i-bus<sup>®</sup> KNX Appendix

Bit No.	7	6	5	4	3	2	1	0		
0	00	0							1	A
1	01	0							2	A
2	02	0							3	A
3	03	0							4	A
4	04	0							5	A
5	05	0							6	A
6	06	0							7	A
7	07	0							8	A
8	08	0							9	A
9	09	0							10	A
10	0A	0							11	A
11	0B	0							12	A
12	0C	0							13	A
13	0D	0							14	A
14	0E	0							15	A
15	0F	0							16	A
16	10	0							17	A
17	11	0							18	A
18	12	0							19	A
19	13	0							20	A
20	14	0							21	A
21	15	0							22	A
22	16	0							23	A
23	17	0							24	A
24	18	0							25	A
25	19	0							26	A
26	1A	0							27	A
27	1B	0							28	A
28	1C	0							29	A
29	1D	0							30	A
30	1E	0							31	A
31	1F	0							32	A
32	20	0							33	A
33	21	0							34	A
34	22	0							35	A
35	23	0							36	A
36	24	0							37	A
37	25	0							38	A
38	26	0							39	A
39	27	0							40	A
40	28	0							41	A
41	29	0							42	A
42	2A	0							43	A
43	2B	0							44	A
44	2C	0							45	A
45	2D	0							46	A
46	2E	0							47	A
47	2F	0							48	A
48	30	0							49	A
49	31	0							50	A
50	32	0							51	A
51	33	0							52	A
52	34	0							53	A
53	35	0							54	A
54	36	0							55	A
55	37	0							56	A
56	38	0							57	A
57	39	0							58	A
58	3A	0							59	A
59	3B	0							60	A
60	3C	0							61	A
61	3D	0							62	A
62	3E	0							63	A
63	3F	0							64	A
64	40	-							-	-
65	41	-							-	-
66	42	-							-	-
67	43	-							-	-
68	44	-							-	-
69	45	-							-	-
70	46	-							-	-
71	47	-							-	-
72	48	-							-	-
73	49	-							-	-
74	4A	-							-	-
75	4B	-							-	-
76	4C	-							-	-
77	4D	-							-	-
78	4E	-							-	-
79	4F	-							-	-
80	50	-							-	-
81	51	-							-	-
82	52	-							-	-
83	53	-							-	-
84	54	-							-	-
85	55	-							-	-

Bit No.	7	6	5	4	3	2	1	0		
86	56	-							-	-
87	57	-							-	-
88	58	-							-	-
89	59	-							-	-
90	5A	-							-	-
91	5B	-							-	-
92	5C	-							-	-
93	5D	-							-	-
94	5E	-							-	-
95	5F	-							-	-
96	60	-							-	-
97	61	-							-	-
98	62	-							-	-
99	63	-							-	-
100	64	-							-	-
101	65	-							-	-
102	66	-							-	-
103	67	-							-	-
104	68	-							-	-
105	69	-							-	-
106	6A	-							-	-
107	6B	-							-	-
108	6C	-							-	-
109	6D	-							-	-
110	6E	-							-	-
111	6F	-							-	-
112	70	-							-	-
113	71	-							-	-
114	72	-							-	-
115	73	-							-	-
116	74	-							-	-
117	75	-							-	-
118	76	-							-	-
119	77	-							-	-
120	78	-							-	-
121	79	-							-	-
122	7A	-							-	-
123	7B	-							-	-
124	7C	-							-	-
125	7D	-							-	-
126	7E	-							-	-
127	7F	-							-	-
128	80	1							1	S
129	81	1							2	S
130	82	1							3	S
131	83	1							4	S
132	84	1							5	S
133	85	1							6	S
134	86	1							7	S
135	87	1							8	S
136	88	1							9	S
137	89	1							10	S
138	8A	1							11	S
139	8B	1							12	S
140	8C	1							13	S
141	8D	1							14	S
142	8E	1							15	S
143	8F	1							16	S
144	90	1							17	S
145	91	1							18	S
146	92	1							19	S
147	93	1							20	S
148	94	1							21	S
149	95	1							22	S
150	96	1							23	S
151	97	1							24	S
152	98	1							25	S
153	99	1							26	S
154	9A	1							27	S
155	9B	1							28	S
156	9C	1							29	S
157	9D	1							30	S
158	9E	1							31	S
159	9F	1							32	S
160	A0	1							33	S
161	A1	1							34	S
162	A2	1							35	S
163	A3	1							36	S
164	A4	1							37	S
165	A5	1							38	S
166	A6	1							39	S
167	A7	1							40	S
168	A8	1							41	S
169	A9	1							42	S
170	AA	1							43	S
171	AB	1							44	S

Bit No.	7	6	5	4	3	2	1	0		
172	AC	1							45	S
173	AD	1							46	S
174	AE	1							47	S
175	AF	1							48	S
176	B0	1							49	S
177	B1	1							50	S
178	B2	1							51	S
179	B3	1							52	S
180	B4	1							53	S
181	B5	1							54	S
182	B6	1							55	S
183	B7	1							56	S
184	B8	1							57	S
185	B9	1							58	S
186	BA	1							59	S
187	BB	1							60	S
188	BC	1							61	S
189	BD	1							62	S
190	BE	1							63	S
191	BF	1							64	S
192	C0	-							-	-
193	C1	-							-	-
194	C2	-							-	-
195	C3	-							-	-
196	C4	-							-	-
197	C5	-							-	-
198	C6	-								

### A.3 Ordering details

Device type	Product Name	Order No.	bbn 40 16779 EAN	Price group	Unit weight 1 pc. [kg]	Packaging (pcs.)
<b>6 A Switch Actuators for resistive, inductive or capacitive loads</b>						
<b>SA/S 4.6.1.1</b>	Switch Actuator, 4-fold 6 A, MDRC	2CDG 110 152 R0011	<b>87786 2</b>		0.18	1
<b>SA/S 8.6.1.1</b>	Switch Actuator, 8-fold, 6 A, MDRC	2CDG 110 153 R0011	<b>87785 5</b>		0.27	1
<b>SA/S 12.6.1.1</b>	Switch Actuator, 12-fold, 6 A, MDRC	2CDG 110 154 R0011	<b>87784 8</b>		0.35	1
<b>6 A Switch Actuators for resistive, inductive or capacitive loads</b>						
<b>SA/S 2.6.2.1</b>	Switch Actuator, 2-fold, 6 A, manual, MDRC	2CDG 110 180 R0011	<b>92506 8</b>		0.18	1
<b>SA/S 4.6.2.1</b>	Switch Actuator, 4-fold, 6 A, manual, MDRC	2CDG 110 181 R0011	<b>92509 9</b>		0.29	1
<b>SA/S 8.6.2.1</b>	Switch Actuator, 8-fold, 6 A, manual, MDRC	2CDG 110 182 R0011	<b>92513 6</b>		0.51	1
<b>SA/S 12.6.2.1</b>	Switch Actuator, 12-fold, 6 A, manual, MDRC	2CDG 110 183 R0011	<b>92515 0</b>		0.74	1
<b>10 A Switch Actuators for resistive, inductive or capacitive loads as well as fluorescent lamp loads (AX)</b>						
<b>SA/S 2.10.2.1</b>	Switch Actuator, 2-fold, 10 A, MDRC	2CDG 110 155 R0011	<b>87783 1</b>		0.18	1
<b>SA/S 4.10.2.1</b>	Switch Actuator, 4-fold, 10 A, MDRC	2CDG 110 156 R0011	<b>87782 4</b>		0.29	1
<b>SA/S 8.10.2.1</b>	Switch Actuator, 8-fold, 10 A, MDRC	2CDG 110 157 R0011	<b>87781 7</b>		0.51	1
<b>SA/S 12.10.2.1</b>	Switch Actuator, 12-fold, 10 A, MDRC	2CDG 110 158 R0011	<b>87780 0</b>		0.74	1
<b>16 A AC1 Switch Actuators for resistive loads</b>						
<b>SA/S 2.16.2.1</b>	Switch Actuator, 2-fold 16 A, MDRC	2CDG 110 159 R0011	<b>87779 4</b>		0.17	1
<b>SA/S 4.16.2.1</b>	Switch Actuator, 4-fold, 16 A, MDRC	2CDG 110 160 R0011	<b>87778 7</b>		0.29	1
<b>SA/S 8.16.2.1</b>	Switch Actuator, 8-fold, 16 A, MDRC	2CDG 110 161 R0011	<b>87777 0</b>		0.51	1
<b>SA/S 12.16.2.1</b>	Switch Actuator, 12-fold, 16 A, MDRC	2CDG 110 162 R0011	<b>87776 3</b>		0.67	1

Device type	Product Name	Order No.	bbn 40 16779 EAN	Price group	Unit weight 1 pc. [kg]	Packaging (pcs.)
<b>16 A Switch Actuators for loads with high peak inrush currents, e.g. lighting equipment with compensation capacitors or fluorescent lamp loads (AX) to EN 60 669, C-load</b>						
<b>SA/S 2.16.5.1</b>	Switch Actuator, 2-fold 16 A, MDRC	2CDG 110 132 R0011	<b>70827 2</b>		0.19	1
<b>SA/S 4.16.5.1</b>	Switch Actuator, 4-fold, 16 A, MDRC	2CDG 110 133 R0011	<b>70828 9</b>		0.31	1
<b>SA/S 8.16.5.1</b>	Switch Actuator, 8-fold, 16 A, MDRC	2CDG 110 134 R0011	<b>70829 6</b>		0.59	1
<b>SA/S 12.16.5.1</b>	Switch Actuator, 12-fold, 16 A, MDRC	2CDG 110 137 R0011	<b>71107 4</b>		0.80	1

**16/20 A Switch Actuators for loads with high peak inrush currents, e.g. lighting equipment with compensation capacitors or fluorescent lamp loads (AX) to EN 60 669, C-load, with current detection**

<b>SA/S 2.16.6.1</b>	Switch Actuator with Current Detection, 2-fold, 16 A, MDRC	2CDG 110 112 R0011	<b>70830 2</b>		0.2	1
<b>SA/S 4.16.6.1</b>	Switch Actuator with Current Detection, 4-fold, 16 A, MDRC	2CDG 110 113 R0011	<b>70831 9</b>		0.38	1
<b>SA/S 8.16.6.1</b>	Switch Actuator with Current Detection, 8-fold, 16 A, MDRC	2CDG 110 114 R0011	<b>70832 6</b>		0.69	1
<b>SA/S 12.16.6.1</b>	Switch Actuator with Current Detection, 12-fold, 16 A, MDRC	2CDG 110 138 R0011	<b>76516 9</b>		0.90	1



**Notes**

**Notes**



# Contact

## **ABB STOTZ-KONTAKT GmbH**

Eppelheimer Straße 82

69123 Heidelberg, Germany

Phone: +49 (0)6221 701 607 (Marketing)

Fax: +49 (0)6221 701 724

E-mail: [knx.marketing@de.abb.com](mailto:knx.marketing@de.abb.com)

## **Further information and local contacts:**

**[www.abb.com/knx](http://www.abb.com/knx)**

## **Notice:**

We reserve the right to make technical changes or modify the contents of this document without prior notice.

The agreed properties are definitive for any orders placed. ABB AG does not accept any responsibility whatsoever for potential errors or possible lack of information in this document.

We reserve all rights in this document and in the subject matter and illustrations contained therein. Reproduction, transfer to third parties or processing of the content – including sections thereof – is not permitted without prior expressed written permission from ABB AG.

Copyright© 2013 ABB

All rights reserved