

PRODUCT MANUAL

ABB i-bus[®] KNX

ABA/S 1.2.1

Logic Controller

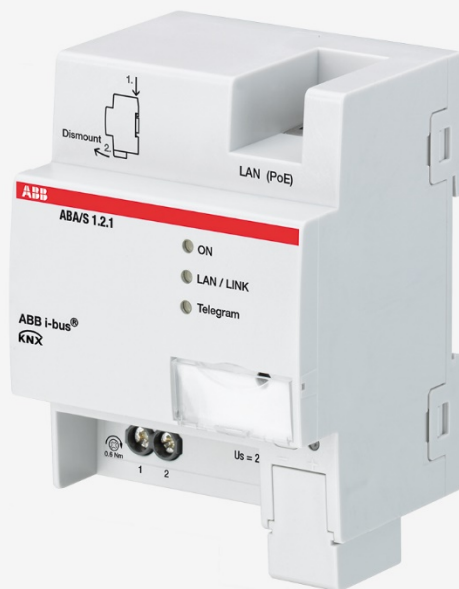

Contents

Page

1	General	7
1.1	Using the product manual.....	7
1.2	Legal disclaimer.....	7
1.3	Explanation of symbols.....	7
2	Safety	9
2.1	General safety instructions.....	9
2.2	Proper use.....	9
2.3	Cyber security (network security).....	9
2.4	Restrict access to the various media.....	9
2.5	Twisted pair cabling.....	10
2.6	IP cabling inside the building.....	10
2.7	Connection to the internet.....	10
3	Product Overview	11
3.1	Product Overview.....	11
3.2	Ordering details.....	11
3.3	Logic Controller ABA/S 1.2.1, MDRC.....	12
3.3.1	Dimension drawing.....	13
3.3.2	Connection diagram.....	14
3.3.3	Operating and display elements.....	15
3.3.4	Technical data.....	16
3.3.4.1	General technical data.....	16
3.3.4.2	Device type.....	18
3.3.4.3	Description of inputs and outputs.....	19
4	Function.....	21
4.1	Overview.....	21
4.2	Functional overview.....	21
4.3	Input functions.....	22
4.4	Output functions.....	22
4.5	Integration in the i-bus [®] Tool.....	22
4.6	Special operating states.....	23
4.6.1	Reaction on bus voltage failure/recovery, download and ETS reset.....	23
4.6.1.1	Bus voltage failure.....	23
4.6.1.2	Bus voltage recovery.....	23
4.6.1.3	ETS reset.....	24
4.6.1.4	Download.....	24
5	Mounting and installation	25
5.1	Information about mounting.....	25
5.2	Mounting on DIN rail.....	26
5.3	Supplied state.....	26

ABB i-bus[®] KNX

Contents

6	Commissioning	27
6.1	Commissioning requirement	27
6.2	Commissioning overview	27
6.3	Assignment of the physical address	27
6.3.1	Network settings	28
6.4	Software/application	28
6.4.1	Download response	28
7	Parameters	29
7.1	General	29
7.2	User interface – menu description	30
7.2.1	<i>File</i> menu	30
7.2.2	<i>Edit</i> menu	31
7.2.3	<i>Realtime</i> menu	31
7.2.4	<i>Simulation</i> menu	31
7.2.5	Worksheet	32
7.2.6	Properties window	32
7.3	Monitor	33
7.4	Simulation	34
7.5	<i>Engine settings</i> parameters	35
7.5.1	Cycle time	35
7.5.2	Use persisting values	35
7.6	<i>Send behavior</i> parameters	35
7.6.1	Minimum time between output telegrams in [s]	35
7.6.2	Minimum time between output telegrams in [ms]	35
7.7	<i>In operation</i> parameters	36
7.7.1	Send Group Object "In Operation" (1-bit)	36
7.7.2	"In Operation" is repeated every	36
7.8	General information on logic calculation	37
7.9	Inverting inputs and outputs	37
7.10	Description of function elements	38
7.10.1	KNX input (KNX IN)	38
7.10.2	KNX output (KNX OUT)	41
7.10.3	Marker Input (MARKER IN)	43
7.10.4	Marker Output (MARKER OUT)	44
7.10.5	AND (AND)	45
7.10.6	OR (OR)	46
7.10.7	XOR (XOR)	47
7.10.8	NOT (NOT)	48
7.10.9	1ofN (ONE-HOT)	49
7.10.10	Greater Than (GREATER)	51
7.10.11	Lower Than (LOWER)	52
7.10.12	Equal (EQUAL)	53
7.10.13	Not Equal (NOT EQUAL)	54
7.10.14	Greater or Equal (GREATER/EQUAL)	55
7.10.15	Lower or Equal (LOWER/EQUAL)	56
7.10.16	Minimum/Maximum (MIN/MAX)	57
7.10.17	Multiplexer, 2 to 1 (1-MUX)	59
7.10.18	Multiplexer, n-fold (n-MUX)	61
7.10.19	Gate (GATE)	63
7.10.20	Filter (FILTER)	64

ABB i-bus[®] KNX

Contents

7.10.21	Addition (ADD).....	65
7.10.22	Multiplication (MULT).....	66
7.10.23	Subtraction (SUB).....	67
7.10.24	Division (DIV).....	68
7.10.25	Modulo (MOD).....	69
7.10.26	Delay (DELAY).....	70
7.10.27	Staircase Light (STAIRC LIGHT).....	72
7.10.28	Calendar, simple (CALENDAR_S).....	74
7.10.29	Calendar (CALENDAR).....	76
7.10.30	Numeric Converter (N-CONV).....	85
7.10.31	RS Flip Flop (RS-FF).....	87
7.10.32	Up Counter (UP COUNT).....	89
7.10.33	PID controller (PID).....	91
7.10.34	Constant (CONST).....	94
7.10.35	Website Input (WEB IN).....	95
7.10.36	Website Output (WEB OUT).....	96
7.10.37	Function Block Input (FB IN).....	97
7.10.38	Function Block Output (FB OUT).....	98
7.10.39	Composite function blocks.....	99
7.10.40	Comment.....	102
7.10.41	Rectangle.....	102
7.10.42	Line.....	102
8	Group objects	103
8.1	Summary of group objects.....	103
8.2	Inputs and outputs.....	104
8.3	Time synchronization.....	104
9	Operation.....	105
9.1	Manual operation.....	105
10	Maintenance and cleaning	107
10.1	Maintenance.....	107
10.2	Cleaning.....	107
11	Disassembly and disposal	109
11.1	Removal.....	109
11.2	Environment.....	110
12	Planning and application	111
13	Appendix	113
13.1	Scope of delivery.....	113
13.2	Notes.....	114

1 General

1.1 Using the product manual

This manual provides detailed technical information relating to the function, installation and programming of the ABB i-bus[®] KNX device.

1.2 Legal disclaimer

We reserve the right to make technical changes or modify the contents of this document without prior notice.

The agreed properties are definitive for any orders placed. ABB AG accepts no responsibility whatsoever for potential errors or possible lack of information in this document.

We reserve all rights in this document and in the subject matter and illustrations contained therein. Reproduction, transfer to third parties or processing of the content – including sections thereof – is not permitted without the prior written consent of ABB AG.

Copyright© 2019 ABB AG

All rights reserved

1.3 Explanation of symbols

1.	Instructions in specified sequence
2.	
▶	Individual actions
a)	Priorities
1)	Processes run by the device in a specific sequence
•	1st-level list
○	2nd-level list

Table 1: Explanation of symbols

Notes and warnings are represented as follows in this manual:



DANGER –

This symbol is a warning about electrical voltage and indicates high-risk hazards that will definitely result in death or serious injury unless avoided.



DANGER –

Indicates high-risk hazards that will definitely result in death or serious injury unless avoided.



WARNING –

Indicates medium-risk hazards that could result in death or serious injury unless avoided.



CAUTION –

Indicates low-risk hazards that could result in slight or moderate injury unless avoided.



ATTENTION –

Indicates a risk of malfunctions or damage to property and equipment, but with no risk to life and limb.

Example:

For use in application, installation and programming examples

Note

For use in tips on usage and operation

2 Safety

2.1 General safety instructions

- ▶ Protect the device from moisture, dirt and damage during transport, storage and operation.
- ▶ Operate the device only within the specified technical data.
- ▶ Operate the device only in a closed housing (distribution board).
- ▶ Mounting and installation must be carried out by qualified electricians.
- ▶ Switch off the device supply voltage before mounting.

2.2 Proper use

The product must be installed centrally in an electrical distribution board.

The device is a modular installation device for quick installation in distribution boards on 35 mm mounting rails to EN 60715.

2.3 Cyber security (network security)

The industry is increasingly faced with cyber security risks. To make its solutions more stable, secure and robust, ABB has officially added cyber security tests to its product development process.

In addition, the information below includes guidelines and mechanisms that you can use to improve the security of KNX systems.

2.4 Restrict access to the various media

The basis of any protection plan is to isolate the system carefully against unauthorized access. Only authorized persons (installers, janitors and users) should have physical access to a KNX system. During planning and installation, the critical points of each KNX medium must be protected as effectively as possible.

In general, applications and devices should be permanently installed to prevent them from being easily removed, allowing unauthorized access to the KNX system. Sub-distributions with KNX devices should be closed, or in rooms to which only authorized persons have access.

2.5 Twisted pair cabling

- ▶ The ends of KNX twisted pair cables should not be visible or protrude from the wall either inside or outside the building.
- ▶ If available, use the anti-theft devices on the application modules.
- ▶ Bus lines in outdoor areas are an increased risk. Ensure that physical access to KNX twisted pair cables is especially difficult here.
- ▶ For extra security, devices installed in areas with limited protection (outdoor areas, underground parking lots, restrooms, etc.) can be designed as a separate line. Enabling the filter tables in the line coupler (KNX only) prevents attackers from gaining access to the whole system.

2.6 IP cabling inside the building

For building automation, use a separate LAN or WLAN network with its own hardware (routers, switches etc.).

Regardless of the KNX system, apply the usual security mechanisms for IP networks. For example:

- MAC filters
- Wireless network encryption
- Use strong passwords and protect them from unauthorized persons

Note

The device cannot be reached during IP, TCP or UDP flooding (access from the internet). To avoid this, set rate limiting at network level.
Please discuss this with your network administrator.

2.7 Connection to the internet

The device's web server uses unencrypted data transfer and is therefore not intended for use on the public internet. To prevent KNX communication from being visible on the internet, ports must not be opened in that direction by routers.

Systems can be accessed via the internet in the following ways:

- Access to KNX installations via VPN connections. However, this requires a router with VPN server functionality or a server.
- Use of manufacturer-specific solutions or visualizations, e.g. access via https.

ABB i-bus[®] KNX

Product Overview

3 Product Overview

3.1 Product Overview

The device is a modular installation device (MDRC) in Pro M design. The module width of the device is four space units. It is designed for installation in distribution boards on 35 mm mounting rails.

The device is supplied via the bus and requires an additional auxiliary voltage, either 24 V DC or Power over Ethernet (PoE). We recommend using a power supply from our range. When using timer functions, date and time must be provided via KNX/TP.

The device connects to the ABB i-bus[®] KNX via the front bus connection terminal.

Engineering Tool Software (ETS) is used for physical address assignment and parametrization.

Once the bus and auxiliary voltages are connected, the device is ready for operation.

Abbreviation	Description
A	Application
B	Module
A	Automation
/S	MDRC
X	1 = Without input and output
X	2 = Middle phase
X	1 = Version number (x = 1, 2 etc.)

Table 2: Product name description

3.2 Ordering details

Description	MB	Type	Order No.	Packaging unit [pcs.]	Weight 1 pc. [g]
Logic Controller	4	ABA/S 1.2.1	2CDG110192R0011	1	192

Table 3: Ordering details

3.3 Logic Controller ABA/S 1.2.1, MDRC



Fig. 1: ABA/S 1.2.1 device illustration

The device is a modular installation device (MDRC) in Pro M design. The module width of the device is four space units. It is designed for installation in distribution boards on 35 mm mounting rails.

The device is supplied via the bus and requires an additional auxiliary voltage, either 24 V DC or Power over Ethernet (PoE). We recommend using a power supply from our range. When using timer functions, date and time must be provided via KNX/TP.

The device connects to the ABB i-bus® KNX via the front bus connection terminal.

Engineering Tool Software (ETS) is used for physical address assignment and parametrization.

Once the bus and auxiliary voltages are connected, the device is ready for operation.

2CDC071001S0016

ABB i-bus[®] KNX Product Overview

3.3.1 Dimension drawing

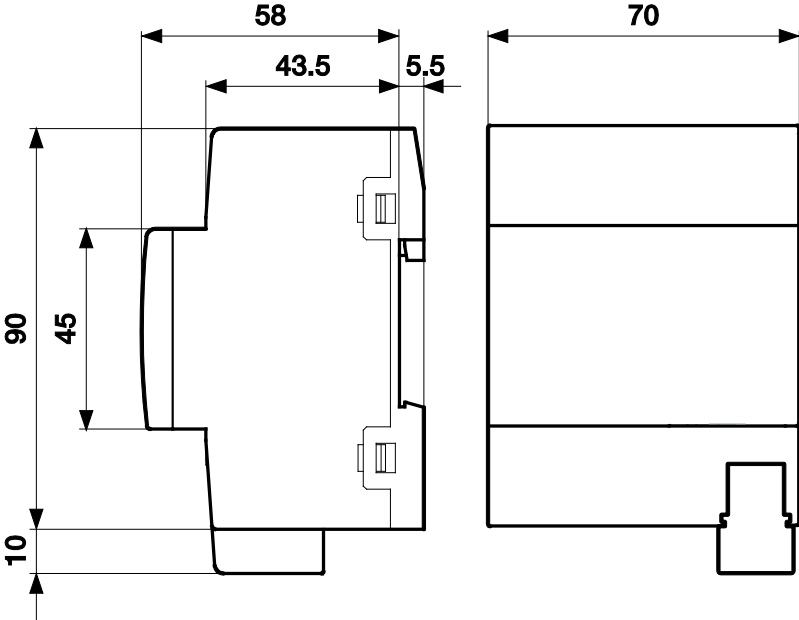

Fig. 2: Dimension drawing

2CDC072033F0015

ABB i-bus[®] KNX

Product Overview

3.3.2 Connection diagram

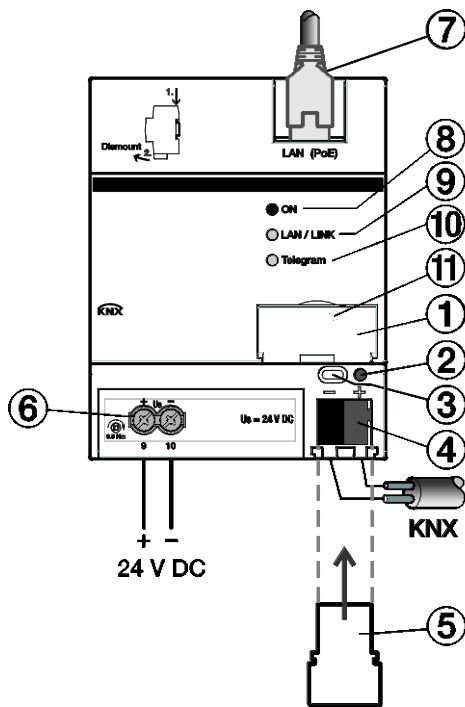

Fig. 3: ABA/S 1.2.1 connection diagram

Legend

- | | | | |
|---|--|----|--|
| 1 | Label carrier | 7 | Ethernet/LAN connection |
| 2 | KNX programming LED (red) | 8 | On LED (green) |
| 3 | KNX programming button | 9 | LAN/LINK LED (yellow) |
| 4 | KNX connection | 10 | KNX telegram LED (yellow) |
| 5 | Cover cap | 11 | Reset/factory settings button (behind label carrier) |
| 6 | Power supply connection U _s | | |

2CDC072034F0015

ABB i-bus[®] KNX

Product Overview

3.3.3

Operating and display elements





Button/LED	Description	LED indicator
	Assignment of the physical address	On: Device is in programming mode
	ON	Off: No auxiliary voltage (24 V or PoE) available On: System initialized Flashing slowly (1 Hz): System starting up Flashing quickly (4 Hz): Error
	LAN/LINK	On: Auxiliary voltage and Ethernet connection available Flickering: Data traffic via LAN
	KNX Telegram	On: Auxiliary voltage and KNX connection available Flickering: Data traffic via KNX/TP
	Reset (behind label carrier)	Press for less than 2 seconds: no reaction. Press for 2 to 10 seconds: device restart. Retains configuration and last states. Press for more than 10 seconds: factory reset. Deletes configuration and all states.

Table 4: Operating and display elements



Note

Device restart and factory reset are only possible when bus voltage and auxiliary voltage are applied.



Note

A firmware update cannot be undone after a factory reset.

ABB i-bus[®] KNX

Product Overview

3.3.4 Technical data

3.3.4.1 General technical data

Supply	Bus voltage	21...32 V DC
	Current consumption, bus	< 12 mA
	Leakage loss, bus	Maximum 250 mW
	Leakage loss, device	Maximum 3 W
	Auxiliary voltage U _s	24 V DC (+20% / -15%) or PoE (IEEE 802.3af class 2)
	Auxiliary voltage current consumption	60 mA typical, 120 mA peak current
	KNX connection	0.25 W
	KNX current consumption	< 10 mA
	Power backup if supply voltage fails	Min. 5 s, typically up to 20 s
	Connections	KNX
Inputs/Outputs		Via screw terminals
LAN		RJ45 socket for 10/100BaseT, IEEE 802.3 networks, AutoSensing
Connection terminals	Screw terminal	Screw terminal with universal head (PZ1)
	Screw terminal 1	0.2...2.5 mm ² stranded, 2 x (0.2...2.5 mm ²)
	Screw terminal 2	0.2...4 mm ² solid, 2 x (0.2...4 mm ²)
	Wire end ferrule without plastic sleeve	0.25...2.5 mm ²
	Wire end ferrule with plastic sleeve	0.25...4 mm ²
	TWIN ferrules	0.25...4 mm ²
	Tightening torque	Max. 0.6 Nm
Protection degree and class	Grid	6.35
	Degree of protection	IP 20 to EN 60529
	Protection class	II to EN 61140
Isolation category	Overvoltage category	III to EN 60664-1
	Pollution degree	II to EN 60664-1
SELV	KNX safety extra low voltage	SELV 24 V DC

ABB i-bus[®] KNX

Product Overview

Temperature range	Operation	-5...+45 °C
	Transport	-25...+70 °C
	Storage	-25...+55 °C
Ambient conditions	Maximum air humidity	93 %, no condensation allowed
	Atmospheric pressure	Atmosphere up to 2,000 m
Design	Modular installation device (MDRC)	Modular installation device
	Design	Pro M
	Housing/color	Plastic housing, gray
Dimensions	Dimensions	90 x 70 x 63.5 mm (H x W x D)
	Mounting width in space units	4x 17.5 mm modules
	Mounting depth	68 mm
Mounting	35 mm mounting rail	To EN 60715
	Mounting Position	Any
	Weight	0.192 kg
	Fire classification	Flammability V-0 as per UL94
Approvals	KNX certification	To EN 50491
CE conformity		In accordance with the EMC directive and low voltage directive

Table 5: Technical data

ABB i-bus[®] KNX

Product Overview

3.3.4.2

Device type

Device type	Logic Controller	ABA/S 1.2.1
	Application	Logic Controller/...*
	Maximum number of group objects	500
	Maximum number of group addresses	2000
	Maximum number of assignments	2000
	Maximum number of logic elements	3000
	WebUI inputs and outputs	60

* ... = Current version number of the application. Please refer the software information on our homepage for this.

Table 6: Device type

Note

ETS and the current version of the device application are required for programming. The latest version of the application and corresponding software information is available for download from www.abb.com/knx. After import into ETS, it appears in the Catalogs window under Manufacturers/ABB/Controller/Controller Output. The device does not support the locking function of a KNX device in ETS. Using a BCU code to inhibit access to all the project devices has no effect on this device. Data can still be read and programmed.

ABB i-bus[®] KNX

Product Overview

3.3.4.3

Description of inputs and outputs

SELV 24 V DC supply voltage input

Only a 24 V DC voltage may be connected to the power supply input. We recommend using a power supply from our range.



CAUTION

The device must be powered either by a 24 V DC voltage or via PoE (Power over Ethernet) according to IEEE 802.3af class 2.

Connecting the device to 230 V may destroy it!

KNX connection

The supplied bus connection terminal is used to connect to the KNX bus.

LAN connection

The device connects to the network via an Ethernet RJ45 interface for LAN networks. The network interface can be operated at a transmission speed of 10/100 Mbit/s. Network activity is indicated by the LAN/LINK LED on the front of the device.

The device features an AutoSensing function and sets the baud rate (10 or 100 Mbit) automatically.

ABB i-bus[®] KNX

Function

4 Function

4.1 Overview

The device provides a comprehensive range of logic functions.

It requires an auxiliary voltage, either 24 V DC or Power over Ethernet (PoE). We recommend using a power supply from our range. When using timer functions, date and time must be provided via KNX/TP.

4.2 Functional overview

This device provides extensive logic functions, which extends the use of KNX to new applications.

The logic engine is generated via a graphic UI integrated in ETS as a plug-in. This provides up to 3,000 logic gates. There is a simulation function for testing generated logic.

User-defined function blocks can be created and saved for use in other projects.

An integrated web server allows you to enter and display up to 60 values.

 **Note**

This function is very basic and is not a substitute for a real visualization.

An internal backup allows the device to continue operating for at least 5 seconds but typically up to 20 seconds in the event of a power failure (24 V DC or PoE). This allows the device to operate normally during a brief voltage drop.

The device is programmed via a KNX/TP bus or IP network.

 **Note**

During KNX/TP programming, extensive logic functions may take a long time to download.

ABB i-bus[®] KNX

Function

4.3 Input functions

Not relevant for this device.

4.4 Output functions

Not relevant for this device.

4.5 Integration in the i-bus[®] Tool

The device features an i-bus[®] Tool interface capable of detecting the device on the network (IP discovery) and updating firmware if required.

You can download the i-bus[®] Tool free of charge from our homepage (www.abb.de/knx).

A description of the functions is provided in the i-bus[®] Tool online help.

4.6 Special operating states

4.6.1 Reaction on bus voltage failure/recovery, download and ETS reset

The device's reaction on bus voltage failure/recovery, download and ETS reset can be set in the device parameters.

If the power fails (24 V DC or PoE), the device safeguards certain internally calculated values, e.g. staircase lighting time or the integral value of the PID controller. The device continues to operate for at least 5 seconds and typically up to 20 seconds using backup power. If power is restored during this time, the device continues to operate normally.

If the power failure exceeds the backup time, the device shuts down safely.

When power has been restored, the device restarts. The KNX inputs behave as per their parameters, i.e. an initial value is set or values are received. See also KNX inputs (KNX IN).

The internal device clock status remains "invalid" until the device receives the time and date via the corresponding KNX group objects.

4.6.1.1 Bus voltage failure

Bus voltage failure describes the sudden drop in/failure of the bus voltage, e.g. due to a power failure.

If the bus voltage fails but the power supply is running, the device continues to operate normally and saves all internal values. Bus-dependent calculations such as the Calendar or Timer function also run normally, but no telegrams are sent.

4.6.1.2 Bus voltage recovery

Bus voltage recovery is the state after bus voltage is restored after failing previously due to a bus voltage failure.

On bus voltage recovery, group objects are updated to their current values. However, they are not sent to the bus during the update. After the update, group objects behave normally again according to the settings on the KNX outputs. See also KNX outputs (KNX OUT).

ABB i-bus[®] KNX

Function

4.6.1.3 ETS reset

Generally an ETS reset is defined as a reset of the device via ETS. To trigger an ETS reset, go to the ETS *Commissioning* menu and select *Reset device*. This deletes all internal information and stops and restarts the device.

4.6.1.4 Download

Downloading describes loading a modified or updated application onto the device with ETS.

Note

After a download with a change, the parameter behaves as if there has been an ETS reset.
If the application is downloaded again (full download) after it has been uninstalled, the reaction is the same as after an ETS reset.
After the application is uninstalled or after an interrupted download, the device no longer functions.

After an ETS download, all internal information is saved and restored. This also applies to internally calculated values (e.g. staircase lighting time and the integral value of the PID controller).

The KNX inputs behave as per their parameters.

If an element was removed from the previous parametrization, its internal value is discarded.

If an element was added, its internal value will be set to the default (usually 0).

ABB i-bus[®] KNX

Mounting and installation

5 Mounting and installation

5.1 Information about mounting

The installation position can be selected as required.

To connect the device to the electrical system, use screw terminals. To connect it to the bus, use the supplied bus connection terminal. The terminal assignment is located on the housing.

Once the bus and auxiliary voltages are connected, the device is ready for operation.

 **Note**

The maximum permissible current of a KNX line must not be exceeded.
During planning and installation ensure that the KNX line is correctly dimensioned.
The device has a maximum current consumption of <10 mA.



DANGER – Severe injuries due to touch voltage

Feedback from differing phase conductors can produce touch voltages and lead to severe injuries.
Operate the device only in a closed housing (distribution board).
Disconnect all phases before working on the electrical connection.

ABB i-bus[®] KNX

Mounting and installation

5.2 Mounting on DIN rail

The device is fitted and removed without auxiliary tools.

Make sure the device is accessible for operation, testing, visual inspection, maintenance and repair.

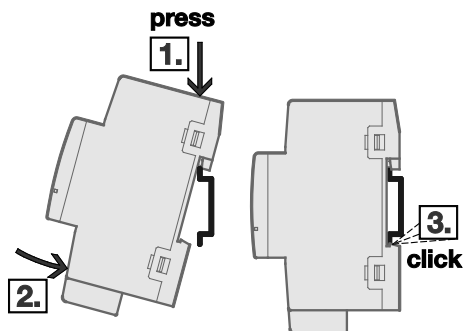

Fig. 4: Mounting on DIN rail

1. Place the DIN rail holder on the upper edge of the DIN rail and push down.
2. Push the lower part of the device toward the DIN rail until the DIN rail holder engages.
⇒ The device is now mounted on the DIN rail.
- ▶ Relieve the pressure on the top of the housing.

5.3 Supplied state

The device is supplied with the physical address 15.15.255. The application is preloaded.

The complete application can be reloaded if required. Downloads may take longer after an application is uninstalled or when changing applications.

2CDC072013F0015

ABB i-bus[®] KNX Commissioning

6 Commissioning

6.1 Commissioning requirement

To commission the device, a PC with ETS is required along with a connection to the ABB i-bus[®], e.g. via a KNX interface.

Once the bus and auxiliary voltages are connected, the device is ready for operation.

6.2 Commissioning overview

The ABA/S 1.2.1 Logic Controller is commissioned using the *Logic Controller*/* application.

 **Note**

* ... = Current version number of the application. Please refer to the software information on our homepage for this.

ETS is required in order to parametrize the device.

For information on how to use the i-bus[®] Tool, see 4.5 [Integration in the i-bus[®] Tool](#)

6.3 Assignment of the physical address

The physical address, group address and parameters are assigned and programmed in ETS.

The device features a *Programming* button for physical address assignment. The red *Programming* LED lights up after the button has been pressed. It goes off once ETS has assigned the physical address or the *Programming* button is pressed again.

The device performs an ETS reset during physical address programming. This resets all states.

ABB i-bus[®] KNX Commissioning

6.3.1 Network settings

DHCP ("Obtain an IP address automatically") is enabled on the device as standard. So the device obtains its IP address from a DHCP server which is often integrated into a network switch or router. If there is no DHCP server, the device is assigned an automatic IP address, usually 169.254.xxx.yyy.

Settings for the IP address are made directly in ETS, where you can also give the device a fixed address. If you do, please ensure that the IP is suitable for the network topology, otherwise the device cannot subsequently be accessed.

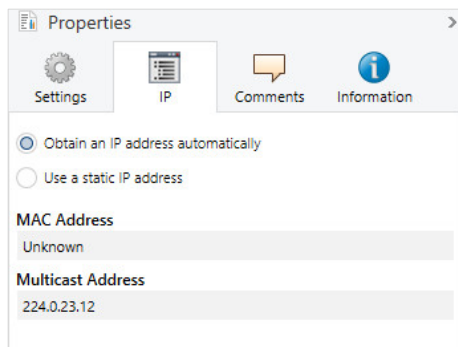

Fig. 5: Network settings

If you have set a fixed IP address, it will be loaded onto the device when you program the physical address. The logic controller is now accessible via the LAN.

If you wish to program the device directly via LAN without a connection to the KNX bus line, select "Use direct IP connection if available" in Bus/Connection Options.

6.4 Software/application

6.4.1 Download response

Due to the complexity of the device, the progress bar for the download may take up to one and a half minutes before it appears depending on the PC used.

ABB i-bus[®] KNX Parameters

7 Parameters

7.1 General

ETS Engineering Tool Software is used to parametrize the device. The device uses an ETS plug-in.
In ETS, the application is located in the *Catalogs* window under *Manufacturers/ABB/Controller/Controller*.
The following sections describe the device functions and parameters.

7.2 User interface – menu description

7.2.1 File menu

Save	Save can only be used after a change.
Export	Exports the whole project to an XML file. Linked group addresses are not exported with the project. You can copy a project with the group addresses using the Copy function in ETS.
Import	If existing data are retained when you import an xml file. The only additional items imported are worksheets.
Import composite function block	Imports a user-defined function block (fbxml file). After import, the composite function block is shown at the bottom left in the list of function elements in <i>Own function blocks</i> .
Print	Options: <ul style="list-style-type: none">• Print All• Print Current Worksheet The size of the printout matches the scaling on the user interface.
Print Preview	Options: <ul style="list-style-type: none">• Full Preview• Previews the current worksheet The size of the print preview matches the scaling on the user interface.
Check	Provides an overview of free resources: <ul style="list-style-type: none">• Elements (total number of function elements)• Used logic link objects (number of socket I/Os)• Used web objects (number of web I/Os)• Download image size (volume of data downloaded to the device)
Settings	General settings for operating the device. More information

ABB i-bus[®] KNX Parameters

7.2.2 **Edit menu**

Grid	Switches on and off the worksheet grid.
Create composite function block	Creates a composite function block from the selected logic. More information
Cut/Copy/Paste	Standard functionality
Undo/Redo	Standard functionality 15 undos/redos are possible.

7.2.3 **Realtime menu**

Real-time device monitoring.
Enabling this function links the plug-in to the device and then shows the live status of the device logic.
The IP address for the connection is taken from the ETS settings.

7.2.4 **Simulation menu**

Offline simulation of the defined logic.
[More information](#)

ABB i-bus[®] KNX Parameters

7.2.5 Worksheet

The worksheet is where you create logical links.

- To create a new worksheet, click the "+" symbol.
- To rename the worksheet, double-click the tab field and overwrite it.

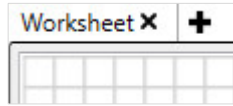

Fig. 6: Worksheet

7.2.6 Properties window

The Properties window is used to parametrize logic elements. In the *Name* field, you can enter a unique name for each logic element, and in the *Remark* field, specific information about it.

ABB i-bus[®] KNX Parameters

7.3 Monitor

Use the Monitor function to view the current states of the logic in the device in real time. The function requires a network connection to the device. To start the monitor, click the following icon:



Fig. 7: Monitor

The plug-in then tries to establish a connection to the logic controller, using the IP address from the ETS settings (Properties > "IP" tab).

When a connection has been established, the current states of the I/O logic link objects are displayed.

Note that the Monitor function can only work if the logic in the device and the plug-in is the same.

7.4 Simulation

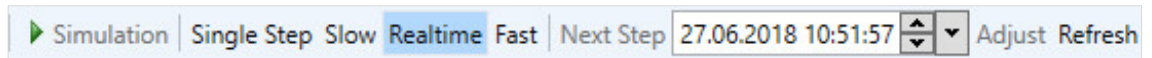

Fig. 8: Simulation

Simulation/Stop	Starts and stops the simulation.
Speeds	Used to select simulation speeds. Important for simulating timer functions such as the Calendar function.
Single Step	Clicking <i>Next Step</i> starts a calculation cycle.
Slow	Around 50 times slower than real time.
Realtime	Simulation is in real time.
Fast	1 second in the simulation is 1 hour in real time.
Simulation time	Sets the simulation time and date. <i>Adjust</i> button: Applies the setting. <i>Refresh</i> button: Synchronizes the date and time with the real time of the PC.

ABB i-bus[®] KNX Parameters

7.5 **Engine settings parameters**

7.5.1 **Cycle time**

Options: 200...65535 (unsigned integer)

Defines the minimum time for the logic engine calculation cycle.

7.5.2 **Use persisting values**

Options: no (no checkmark)
yes (checkmark)

- **yes:** The device stores the internal information of certain function elements. To see which data are saved, please refer to the descriptions for the relevant function elements.

7.6 **Send behavior parameters**

7.6.1 **Minimum time between output telegrams in [s]**

Options: 0...255 s (unsigned integer)

7.6.2 **Minimum time between output telegrams in [ms]**

Options: 0...2000 ms (unsigned integer)

Note

The parameters *Minimum time between output telegrams in [s]* and *Minimum time between output telegrams in [ms]* refer both to "normal" KNX telegrams and ValueRead telegrams.

ABB i-bus[®] KNX

Parameters

7.7 ***In operation* parameters**

7.7.1 **Send Group Object "In Operation" (1-bit)**

Options: No
 Send value 0 cyclically
 Send value 1 cyclically

The *In operation* group object indicates that the device is communicating correctly with the KNX bus. Depending on the setting, a 0 or 1 is sent cyclically and activates the 1-bit group object *In operation*. The cyclical telegram can be evaluated by other devices on the bus.

7.7.2 **"In Operation" is repeated every**

Options: 00:00:01...01:00:00...11:59:59 hh:mm:ss

ABB i-bus[®] KNX Parameters

7.8 General information on logic calculation

The logic controller calculates generated logic cyclically. The default engine cycle time setting is 200 ms but this can be increased if required. See [Cycle time](#).

Logic is always calculated from the inputs to the outputs (left to right). There is no loop capability.

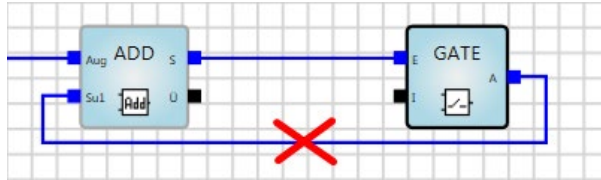

Fig. 9: General information on logic calculation

A calculation cycle calculates the entire logic. New values (e.g. from the KNX bus) available at the start of the cycle are taken into account.

7.9 Inverting inputs and outputs

1-bit inputs and outputs can be inverted by double-clicking the related input/output.

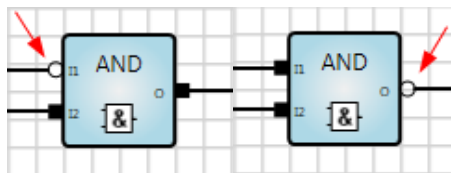
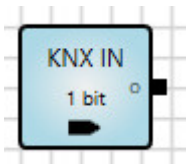

Fig. 10: Inverting inputs and outputs

7.10 Description of function elements

7.10.1 KNX input (KNX IN)



Description

Selects the KNX input element based on the required datapoint type. Received values are sent to the logic engine. Enables a corresponding group object in ETS.

Note

You can enter a unique name for the element in the *Name* field in the Properties-section. The name will also be written into the Group Object Description in ETS.

Send outputs

No.	DPT	Abbr.	Name	Visible	Description
1	Any	O	Output	Always	
2	1 bit	Rcv	Telegram received	Parametrizable	Checkbox selected: Every telegram received triggers a status send pulse with the value 0/1. The next calculation (usually after 200 ms) resets the value to 0.

Parameters

Name	Value	Visible	Description
Initial value	According to DPT	Always	A preset value intended for use in calculations. This value is only used if <i>Set initial value after restart</i> is enabled. Note: Selecting the checkbox sets the initial value to 1, but only with 1-bit values. Deselecting the checkbox (default) sets the initial value to 0.
Set initial value after restart	1 (true) 0 (false)	Always	Selected via checkbox. After a restart, either the initial value is used or the input value is restored, or the system waits for a telegram to arrive.
Read group address	1 (true) 0 (false)	If <i>Set initial value after restart</i> is deselected	Selected via checkbox. Selecting the checkbox sets the "READ ON INIT" flag.

ABB i-bus[®] KNX Parameters

Description of parameters

Initial value:

Initial value of the input. May only be used in combination with the Set initial value after restart parameter.

Set initial value after restart:

If the checkbox is selected for this parameter, the input will have the defined initial value on restart. If it is not, the device first tries to restore the input value.

If the restore is successful the input will use this value and will not trigger a recalculation.

If the restore is unsuccessful, the input value is initially undefined. Only a subsequent valid telegram will update it.

There will be a restart after a download, on supply voltage recovery or on bus voltage recovery.

Read group address:

If the checkbox is selected for this parameter the "READ ON INIT" flag in the object sends one "Value Read" command to the bus on restart or after a download.



Note

If this parameter is enabled, the logic engine waits for the calculation until all inputs of a logical link have a valid value. Elements without a direct or indirect link are not calculated.

Function

Whenever a telegram is received the input starts a recalculation independently if the value has changed.

Bus voltage failure, download and restart

The input values are saved. On restart the input reacts as per the corresponding parameter.

ABB i-bus[®] KNX Parameters

Element display

- Element name
- First group address
- Data widths (1 bit, 2 bits, 4 bits, 1 byte, 2 bytes, 4 bytes, date, time, date/time, color)

Note

The first group address is the one that sends a value. The group addresses are displayed in the same layout as in ETS (e.g. 2-level or 3-level).

Icons:

- Read group address = True (1):  icon

Datapoint type

Select the datapoint type required for displaying the value on the KNX accordingly.

All assigned group addresses are listed in Data Types in the *Properties* window. They cannot be changed (read-only).

ABB i-bus[®] KNX Parameters

7.10.2

KNX output (KNX OUT)

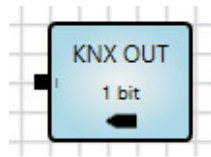

Description

Selects the KNX output element based on the required datapoint type. Received values from the logic engine are forwarded. Enables a corresponding group object in ETS.

Note

You can enter a unique name for the element in the *Name* field in the Properties-section. The name will also be written into the Group Object Description in ETS.

Inputs

No.	DPT	Abbr.	Name	Visible	Description
1	Any	I	Input	Always	

Parameters

Name	Value	Visible	Description
Send behavior	<u>Send on change</u> Always	Always	Values can always be sent, i.e. after every recalculation of the link results, or only when a value in the results changes.
Change defined in	Absolute Relative (%)	If Send behavior = Send on change*	If <i>Send on change</i> is selected for <i>Send behavior</i> , an absolute or relative value can be output after a value change.
Change absolute	Value dependent on DPT, default = 1	If Change defined in = Absolute*	A value is sent if <i>Change defined in</i> is greater or less than the number entered in <i>Change absolute</i> .
Change in %	[0.1 %, 0.2 %, 0.5 %, <u>1 %</u> , 2 %, ..., 20 %]	If Change defined in = Relative (%)*	A value is sent if the <i>Change defined in</i> percentage of the last value sent is greater or less than the percentage selected in <i>Change in %</i> .
Cyclic sending	1 (true) <u>0 (false)</u>	Always	Cyclic sending can be enabled by selecting the checkbox.
Cycle time	min:sec, minimum value = 00:09	If Cyclic sending = true (1)	If the <i>Cyclic sending</i> checkbox is selected, the cycle time can be set from a minimum value of 00:09 (in min:sec).

* only visible if the chosen DPT are integers or float values (1 to 4 bytes)

ABB i-bus[®] KNX

Parameters

Description of parameters

Change in %:

The value change is defined as follows:

$(\text{NEW_VALUE} - \text{LAST_SENT_VALUE}) / \text{LAST_SENT_VALUE}$

If $\text{NEW_VALUE} = \text{LAST_SENT_VALUE} = 0$, result is 0%

If $\text{NEW_VALUE} <> 0$ and $\text{LAST_SENT_VALUE} = 0$, result is 100%

Function

Whenever a telegram is received the output starts a recalculation independently if the value has changed.

Bus voltage failure, download and restart

The output values are not saved. Cyclic sending starts once the output receives a valid value.

Output values that cannot be sent on the bus (e.g. due to bus load or bus voltage failure) are overwritten by newer values.

Element display

- Element name
- First group address
- Data widths (1 bit, 2 bits, 4 bits, 1 byte, 2 bytes, 4 bytes, date, time, date/time, color)

Note

The first group address is the one that sends a value. The group addresses are displayed in the same layout as in ETS (e.g. 2-level or 3-level).

Datapoint Type

Select the datapoint type required for displaying the value on the KNX accordingly.

All assigned group addresses are listed in Data Types in the *Properties* window. They cannot be changed (read-only).

ABB i-bus[®] KNX Parameters

7.10.3

Marker Input (MARKER IN)



Description

Markers are used for distant links. Links between worksheets are also possible. A marker input is logically linked to a marker output.

Important: A marker input can only be linked to exactly one marker output!



Note

For easy identification you should enter a unique name for the corresponding marker in the *Name* field in the properties.

Outputs

No.	DPT	Abbr.	Name	Visible	Description
1	Any	O	Output	Always	

Parameters

Name	Value	Visible	Description
Linked to	List of all MARKER OUTs	Always	Selects the MARKER OUT to be linked with the MARKER IN

ABB i-bus[®] KNX Parameters

7.10.4

Marker Output (MARKER OUT)



Description

Markers are used for distant links. Links between worksheets are also possible. A marker output is logically linked to one or more marker inputs.

Note

For easy identification you should enter a unique name for the corresponding marker in the *Name* field in the properties.

Inputs

No.	DPT	Abbr.	Name	Visible	Description
1	Any	I	Input	Always	

Parameters

Name	Value	Visible	Description
Linked to	List of all MARKER INs	Always	Selects the MARKER IN to be linked with the MARKER OUT

ABB i-bus[®] KNX Parameters

7.10.5

AND (AND)

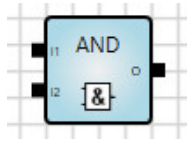

Description

Logical AND operator.

Inputs

No.	DPT	Abbr.	Name	Visible	Description
1	1 bit	I ₁	Input	Always	
2	1 bit	I ₂	Input	Always	
3-16	1 bit	I _n	Input	Parametrizable	n = 3...16

Outputs

No.	DPT	Abbr.	Name	Visible	Description
1	1 bit	O	Output	Always	

Note

An AND element can be easily inverted to a NAND element by double-clicking the output.

Parameters

Name	Value	Visible	Description
Input Count	2...16	Always	

Function

Whenever a telegram is received the output starts a recalculation independently if the value has changed. The output is true (1) if all inputs are true (1).

I ₁	I ₂	O
0	0	0
0	1	0
1	0	0
1	1	1

Other

Inputs not connected are treated as if they did not exist.

ABB i-bus[®] KNX Parameters

7.10.6

OR (OR)

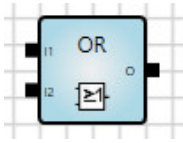

Description

Logical OR operator.

Inputs

No.	DPT	Abbr.	Name	Visible	Description
1	1 bit	I ₁	Input	Always	
2	1 bit	I ₂	Input	Always	
3-16	1 bit	I _n	Input	Parametrizable	n = 3...16

Outputs

No.	DPT	Abbr.	Name	Visible	Description
1	1 bit	O	Output	Always	

Note

An OR element can be easily inverted to a NOR element by double-clicking the output.

Parameters

Name	Value	Visible	Description
Input count	2...16	Always	

Function

Whenever a telegram is received the output starts a recalculation independently if the value has changed. The output is true (1) if at least one input is true (1).

I ₁	I ₂	O
0	0	0
0	1	1
1	0	1
1	1	1

Other

Inputs not connected are treated as if they did not exist.

ABB i-bus[®] KNX Parameters

7.10.7

XOR (XOR)

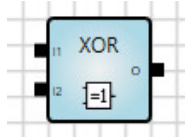

Description

Logical XOR operator (exclusive OR).

Inputs

No.	DPT	Abbr.	Name	Visible	Description
1	1 bit	I ₁	Input	Always	
2	1 bit	I ₂	Input	Always	
3-16	1 bit	I _n	Input	Parametrizable	n = 3...16

Outputs

No.	DPT	Abbr.	Name	Visible	Description
1	1 bit	O	Output	Always	



Note

A XOR element can be easily inverted to a XNOR element by double-clicking the output.

Parameters

Name	Value	Visible	Description
Input Count	2...16	Always	

Function

Whenever a telegram is received the output starts a recalculation independently if the value has changed. The output is true (1) if there is an odd number of true (1) inputs.

I ₁	I ₂	I ₃	O
0	0	0	0
0	0	1	1
0	1	0	1
0	1	1	0
1	0	0	1
1	0	1	0
1	1	0	0
1	1	1	1

Other

Inputs not connected are treated as if they did not exist. If only one input is linked, the output value is the same as the input value.

ABB i-bus[®] KNX Parameters

7.10.8

NOT (NOT)

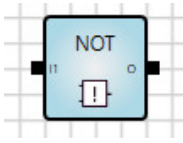

Description

Logical NOT operator.

Inputs

No.	DPT	Abbr.	Name	Visible	Description
1	1 bit	I ₁	Input	Always	

Outputs

No.	DPT	Abbr.	Name	Visible	Description
1	1 bit	O	Output	Always	

Note

1-bit inputs and outputs can be inverted by double-clicking the related input/output.

Parameters

None

Function

Whenever a telegram is received the output starts a recalculation independently if the value has changed. The input value is output negated.

I	O
0	1
1	0

ABB i-bus[®] KNX Parameters

7.10.9

1ofN (ONE-HOT)

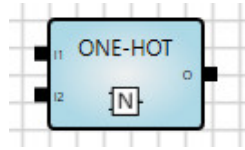

Description

Logical 1ofN operator.

Inputs

No.	DPT	Abbr.	Name	Visible	Description
1	1 bit	I ₁	Input	Always	
2	1 bit	I ₂	Input	Always	
3-16	1 bit	I _n	Input	Parametrizable	n = 3...16

Outputs

No.	DPT	Abbr.	Name	Visible	Description
1	1 bit	O	Output	Always	



Note

You can invert 1-bit inputs and outputs by double-clicking on the relevant I/O.

Parameters

Name	Value	Visible	Description
Input Count	2...16	Always	

Function

Whenever a telegram is received the output starts a recalculation independently if the value has changed. The output is true (1) if exactly one input is true (1).

I ₁	I ₂	I ₃	O
0	0	0	0
0	0	1	1
0	1	0	1
0	1	1	0
1	0	0	1
1	0	1	0
1	1	0	0
1	1	1	0

ABB i-bus[®] KNX Parameters

Application Example

You want to ensure that from a set of outputs, exactly one has the value 1 while the other outputs are 0. The circuit shown ensures that this is the case.

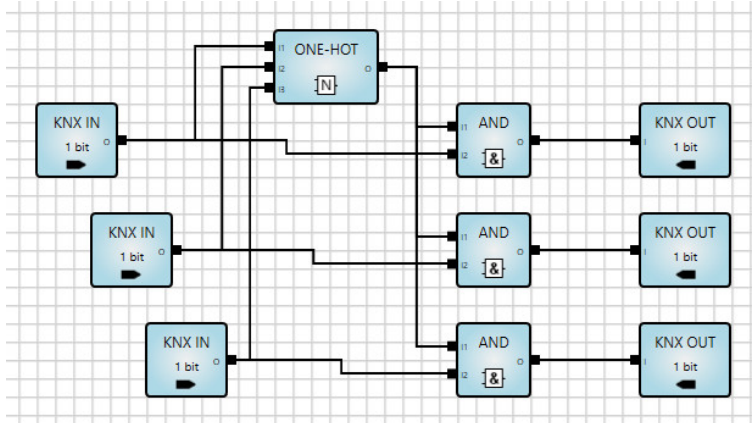

Fig. 11: Application example, 1ofN element

If more than one of the three input values is 1, this results in a 1ofN operator is equal to 0. The AND logic gates therefore force the three output values to 0.

Other

Inputs not connected are treated as if they did not exist.

ABB i-bus[®] KNX Parameters

7.10.10

Greater Than (GREATER)

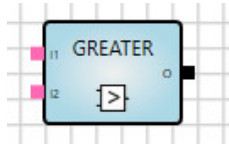

Description

Comparison of two input values. Both inputs can also be linked with fixed values (constant).

Inputs

No.	DPT	Abbr.	Name	Visible	Description
1	Numerical value	I ₁	Input	Always	
2	Same as Input 1	I ₂	Input	Parametrizable	

Outputs

No.	DPT	Abbr.	Name	Visible	Description
1	1 bit	O	Output	Always	

Parameters

Name	Value	Visible	Description
In 2	Checkbox	Always	
	Numerical value	If the checkbox is cleared	Data type as for Input 1

Function

The output is 1 if I₁ is greater than I₂.

The output is 0 if I₁ is less than or equal to I₂.

Whenever a telegram is received the output starts a recalculation independently if the value has changed.

ABB i-bus[®] KNX Parameters

7.10.11

Lower Than (LOWER)

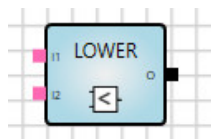

Description

Comparison of two input values. Both inputs can also be linked with fixed values (constant).

Inputs

No.	DPT	Abbr.	Name	Visible	Description
1	Numerical value	I ₁	Input	Always	
2	Same as Input 1	I ₂	Input	Parametrizable	

Outputs

No.	DPT	Abbr.	Name	Visible	Description
1	1 bit	O	Output	Always	

Parameters

Name	Value	Visible	Description
In 2	Checkbox	Always	
	Numerical value	If the checkbox is cleared	Data type as for Input 1

Function

The output is 1 if I₁ is less than I₂.

The output is 0 if I₁ is greater than or equal to I₂.

Whenever a telegram is received the output starts a recalculation independently if the value has changed.

ABB i-bus[®] KNX Parameters

7.10.12

Equal (EQUAL)

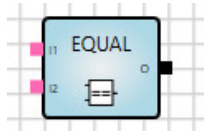

Description

Comparison of two input values. Both inputs can also be linked with fixed values (constant).

Inputs

No.	DPT	Abbr.	Name	Visible	Description
1	Numerical value	I ₁	Input	Always	
2	Same as Input 1	I ₂	Input	Parametrizable	

Outputs

No.	DPT	Abbr.	Name	Visible	Description
1	1 bit	O	Output	Always	

Parameters

Name	Value	Visible	Description
In 2	Checkbox	Always	
	Numerical value	If the checkbox is cleared	Data type as for Input 1

Function

The output is 1 if I₁ is equal to I₂.

The output is 0 if I₁ is not equal to I₂.

Whenever a telegram is received the output starts a recalculation independently if the value has changed.

ABB i-bus[®] KNX Parameters

7.10.13

Not Equal (NOT EQUAL)

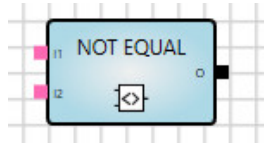

Description

Comparison of two input values. Both inputs can also be linked with fixed values (constant).

Inputs

No.	DPT	Abbr.	Name	Visible	Description
1	Numerical value	I ₁	Input	Always	
2	Same as Input 1	I ₂	Input	Parametrizable	

Outputs

No.	DPT	Abbr.	Name	Visible	Description
1	1 bit	O	Output	Always	

Parameters

Name	Value	Visible	Description
In 2	Checkbox	Always	
	Numerical value	If the checkbox is cleared	Data type as for Input 1

Function

The output is 1 if I₁ is not equal to I₂.

The output is 0 if I₁ is equal to I₂.

Whenever a telegram is received the output starts a recalculation independently if the value has changed.

ABB i-bus[®] KNX Parameters

7.10.14

Greater or Equal (GREATER/EQUAL)

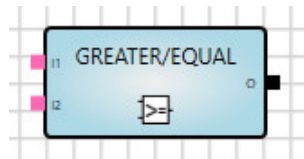

Description

Comparison of two input values. Both inputs can also be linked with fixed values (constant).

Inputs

No.	DPT	Abbr.	Name	Visible	Description
1	Numerical value	I ₁	Input	Always	
2	Same as Input 1	I ₂	Input	Parametrizable	

Outputs

No.	DPT	Abbr.	Name	Visible	Description
1	1 bit	O	Output	Always	

Parameters

Name	Value	Visible	Description
In 2	Checkbox	Always	
	Numerical value	If the checkbox is cleared	Data type as for Input 1

Function

The output is 1 if I₁ is greater than or equal to I₂.

The output is 0 if I₁ is less than I₂.

Whenever a telegram is received the output starts a recalculation independently if the value has changed.

ABB i-bus[®] KNX Parameters

7.10.15

Lower or Equal (LOWER/EQUAL)

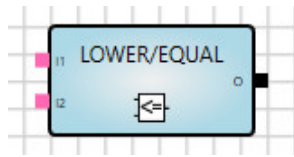

Description

Comparison of two input values. Both inputs can also be linked with fixed values (constant).

Inputs

No.	DPT	Abbr.	Name	Visible	Description
1	Numerical value	I ₁	Input	Always	
2	Same as Input 1	I ₂	Input	Parametrizable	

Outputs

No.	DPT	Abbr.	Name	Visible	Description
1	1 bit	O	Output	Always	

Parameters

Name	Value	Visible	Description
In 2	Checkbox	Always	
	Numerical value	If the checkbox is cleared	Data type as for Input 1

Function

The output is 1 if I₁ is less than or equal to I₂.

The output is 0 if I₁ is greater than I₂.

Whenever a telegram is received the output starts a recalculation independently if the value has changed.

ABB i-bus[®] KNX Parameters

7.10.16

Minimum/Maximum (MIN/MAX)

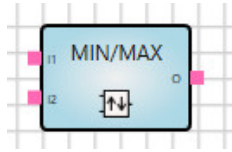

Description

Finds the largest or smallest of up to 16 values. The inputs can also be linked with fixed values (constant).

Inputs

No.	DPT	Abbr.	Name	Visible	Description
1	1 bit	F	Function	Parametrizable	
2	Any	I ₁	Input	Always	
3	Any	I ₂	Input	Always	
4-16	Any	I _n	Input	Parametrizable	n = 3...16

Outputs

No.	DPT	Abbr.	Name	Visible	Description
1	Any	O	Output	Always	

Parameters

Name	Value	Visible	Description
Input Count	2-16	Always	

Input parameters

Name	Value	Visible	Description
Min	Checkbox	Always	Enables element input F
	Checkbox	If the checkbox is cleared	1 = Minimum 0 = Maximum

ABB i-bus[®] KNX

Parameters

Function

Input F defines, if MIN or MAX function is activated.

If F = 0, the output sends the largest input value (I1-I16). Function MAX is activated.

If F = 1, the output sends the smallest input value (I1-I16). Function MIN is activated.

The output sends:

- On a value change at the output (new input values will be set).
- When input F receives a value

Exception handling

Unlinked inputs are not taken into account.

Other

If only one input is linked, the output value is the same as the input value.

ABB i-bus[®] KNX Parameters

7.10.17

Multiplexer, 2 to 1 (1-MUX)

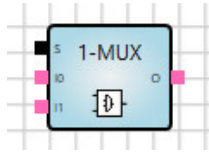

Description

Selects a value from two input values.

Inputs

No.	DPT	Abbr.	Name	Visible	Description
1	1 bit	S	Select	Always	
2	Any	I ₀	Input	Always	
3	Any	I ₁	Input	Always	

Outputs

No.	DPT	Abbr.	Name	Visible	Description
1	1 bit	O	Output	Always	

Parameters

Name	Value	Visible	Description
Send trigger	yes <u>no</u>		Checkbox: yes: The output sends when Select receives a value. no: The output does not send when Select receives a value.

ABB i-bus[®] KNX Parameters

Function

If Select has the value 1, input I_1 is sent to the output. If Select has the value 0, input I_0 is sent to the output.

Values received on unselected inputs are stored until the input is selected.

Whenever a telegram is received the output starts a recalculation independently if the value has changed.

Application example

This element can also be used as a send trigger.

In the example below, the result of the MIN/MAX element is always triggered for sending when the "Update" input receives a telegram. The *Send trigger* parameter in 1-MUX must be selected.

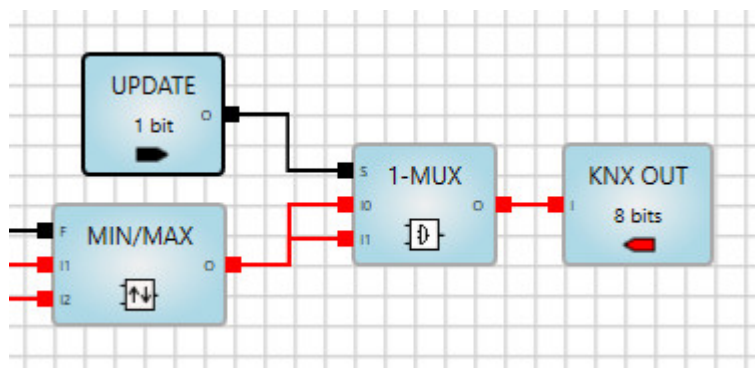

Fig. 12: Application example, simple multiplexer element

Other

If an unlinked input is selected, the output value remains unchanged.

ABB i-bus[®] KNX Parameters

7.10.18

Multiplexer, n-fold (n-MUX)

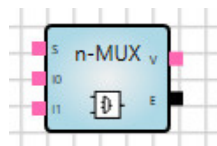

Description

Selects a value from up to 16 input values.

Inputs

No.	DPT	Abbr.	Name	Visible	Description
1	1 byte unsigned 2 byte unsigned 4 byte unsigned	S	Select	Always	
2	Any	I ₀	Input	Always	
3	Any	I ₁	Input	Always	
4-17	Any	I _n	Input	Parametrizable	n = 2...15

Outputs

No.	DPT	Abbr.	Name	Visible	Description
1	Any	V	Value	Always	
2	1 bit	E	Error	Always	

Parameters

Name	Value	Visible	Description
Input Count	2...16	Always	

ABB i-bus[®] KNX Parameters

Function

The *Select* value defines which input value is sent to the output.

Values received on unselected inputs are stored until the input is selected.

The output is recalculated and updated every time if any of the inputs or *Select* receives a value.

Note

Select starts with the value 0.

Exception handling

If the value on the selected input or in *Select* is invalid, the output will not react.

The Output E (Error) is set to 1. It resets to 0 as soon as both *Select* and the selected input have valid values.

Other

If an unlinked input is selected, the output value remains unchanged.

ABB i-bus[®] KNX Parameters

7.10.19

Gate (GATE)

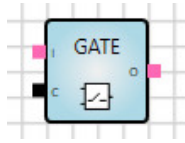

Description

Disables or enables the transmission of values. If the Gate is disabled, the output remains unchanged and will not trigger a recalculation.

Inputs

No.	DPT	Abbr.	Name	Invertible	Visible	Description
1	Any	I	Input	No	Always	
2	1 bit	C	Control	Yes	Always	Disables/enables the output

Outputs

No.	DPT	Abbr.	Name	Invertible	Visible	Description
1	Any	O	Output	No	Always	

Parameters

Name	Value	Visible	Description
Control triggers calculation	<u>yes</u> no	Always	yes: The output sends a value every time a value is received on the Control input.

Function

Control = 1 (true): The output sends every time an input value is received (enabled)

Control = 0 (false): The output does not send (disabled)

Other

If the Control input is not connected, the transmission of values through the gate element is enabled.

ABB i-bus[®] KNX Parameters

7.10.20

Filter (FILTER)

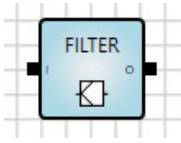

Description

The filter blocks 1-bit telegram values (0 or 1).

Inputs

No.	DPT	Abbr.	Name	Invertible	Visible	Description
1	1 bit	I	Input	Yes	Always	

Outputs

No.	DPT	Abbr.	Name	Invertible	Visible	Description
1	1 bit	O	Output	Yes	Always	

Parameters

Name	Value	Visible	Description
Blocked Value	none (no filter)	Always	none (no filter)
	0		0 (value 0 blocked)
	1		1 (value 1 blocked)

Function

The output sends when the input receives a value that is not blocked.

If the *None* option is selected for the *Blocked Value* parameter, the filter element forwards all values received.

Application examples

- A presence detector sends 1-bit values. After a defined time it sends the value 0 to switch off the light. Other appliances are not to react to this value 0 because they have their own timer control.
- A push-button or a key card triggers the sending of 1-bit values, 1 or 0. The two values are to trigger different actions.
- The staircase lighting will switch off after receiving the value 0. If this action is not required, the value 0 can be blocked by a filter.

Other

Inputs not connected are treated as if they did not exist.

ABB i-bus[®] KNX Parameters

7.10.21

Addition (ADD)

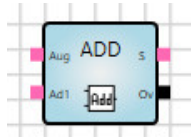

Description

Sums up to 16 input values.

Inputs

No.	DPT	Abbr.	Name	Visible	Description
1	8 bit or higher	Aug	Augend	Always	
2	Same as Input 1	Ad ₁	Addend	Always	
3	Same as Input 1	Ad _n	Addend	Parametrizable	n = 2...15

Outputs

No.	DPT	Abbr.	Name	Visible	Description
1	Same as Input 1	S	Sum	Always	
2	1 bit	Ov	Overflow	Always	Indicates an overflow

Parameters

Name	Value	Visible	Description
Input count	2...16	Always	

Function

Whenever a telegram is received the output starts a recalculation independently if the value has changed.

An overflow will occur if the calculated value is outside the DPT range:

- If the calculated value is greater than the maximum DPT value:
 - S = 0
 - Ov = 1 (true)
- If the calculated value is less than the minimum DPT value:
 - S = 0
 - Ov = 1 (true)
- If the calculated value is within the valid range of the DPT:
 - S = Sum of all linked output values
 - Ov = 0 (false)

Other

Inputs not connected are treated as if they did not exist.

ABB i-bus[®] KNX Parameters

7.10.22

Multiplication (MULT)

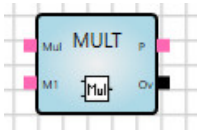

Description

Multiplies up to 16 input values.

Inputs

No.	DPT	Abbr.	Name	Visible	Description
1	8 bit or higher	Mul	Multiplicand	Always	
2	Same as Input 1	M ₁	Multiplier	Always	
3-16	Same as Input 1	M _n	Multiplier	Parametrizable	n = 2...15

Outputs

No.	DPT	Abbr.	Name	Visible	Description
1	Same as Input 1	P	Product	Always	
2	1 bit	Ov	Overflow	Always	Indicates an overflow

Parameters

Name	Value	Visible	Description
Input Count	2...16	Always	

Function

Whenever a telegram is received the output starts a recalculation independently if the value has changed.

An overflow will occur if the calculated value is outside the DPT range:

- If the calculated value is greater than the maximum DPT value:
 - P = 0
 - Ov = 1 (true)
- If the calculated value is less than the minimum DPT value:
 - P = 0
 - Ov = 1 (true)
- If the calculated value is within the valid range of the DPT:
 - P = Product of all linked input values
 - Ov = 0 (false)

Other

Inputs not connected are treated as if they did not exist.

ABB i-bus[®] KNX Parameters

7.10.23

Subtraction (SUB)

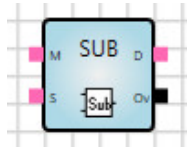

Description

Subtracts one input value (subtrahend) from another (minuend).

Inputs

No.	DPT	Abbr.	Name	Visible	Description
1	8 bit or higher	M	Minuend	Always	
2	Same as Input 1	S	Subtrahend	Always	

Outputs

No.	DPT	Abbr.	Name	Visible	Description
1	Same as Input 1	D	Difference	Always	
2	1 bit	Ov	Overflow	Always	Indicates an overflow

Parameters

None

Function

Whenever a telegram is received the output starts a recalculation independently if the value has changed.

An overflow will occur if the calculated value is outside the DPT range:

- If the calculated value is greater than the maximum DPT value:
 - D = 0
 - Ov = 1 (true)
- If the calculated value is less than the minimum DPT value:
 - D = 0
 - Ov = 1 (true)
- If the calculated value is within the valid range of the DPT:
 - D = Difference between the two input values (Minuend - Subtrahend)
 - Ov = 0 (false)

Other

Unlinked inputs are treated as if they did not exist and are set to 0.

ABB i-bus[®] KNX Parameters

7.10.24

Division (DIV)

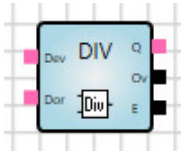

Description

Divides one input value (dividend) by another (divisor).

Inputs

No.	DPT	Abbr.	Name	Visible	Description
1	8 bit or higher	Dev	Dividend	Always	
2	Same as Input 1	Dor	Divisor	Always	

Outputs

No.	DPT	Abbr.	Name	Visible	Description
1	Same as Input 1	Q	Quotient	Always	
2	1 bit	Ov	Overflow	Always	Indicates an overflow
3	1 bit	E	Error	Always	Indicates a division by 0

Parameters

None

Function

Whenever a telegram is received the output starts a recalculation independently if the value has changed.

An overflow will occur if the calculated value is outside the DPT range:

- If the calculated value is greater than the maximum DPT value:
 - Q = 0
 - Ov = 1 (true)
 - E = 0 (false)
- If the calculated value is less than the minimum DPT value:
 - Q = 0
 - Ov = 1 (true)
 - E = 0 (false)
- If the calculated value is within the valid range of the DPT:
 - Q = Quotient of the two input values (Dividend : Divisor)
 - Ov = 0 (false)
 - E = 0 (false)
- Value of Divisor = 0:
 - Q = 0
 - Ov = 0 (false)
 - E = 1 (true)

Other

Inputs not connected are treated as if they did not exist.

ABB i-bus[®] KNX Parameters

7.10.25

Modulo (MOD)

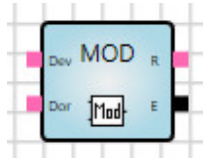

Description

Calculates the remainder from dividing one input value (dividend) by another (divisor).

Inputs

No.	DPT	Abbr.	Name	Visible	Description
1	8 bit or higher	Dev	Dividend	Always	
2	Same as Input 1	Dor	Divisor	Always	

Outputs

No.	DPT	Abbr.	Name	Visible	Description
1	Same as Input 1	R	Remainder	Always	Remainder of the division
2	1 bit	E	Error	Always	Indicates a division by 0

Parameters

None

Function

Whenever a telegram is received the output starts a recalculation independently if the value has changed.

Remainder and Error:

- The dividend is divided by the divisor and the value from the division is within the valid range of the DPT. Output of the remainder:
 - R = value
 - E = 0 (false)
- The input is not linked or the value of the divisor = 0:
 - R = 0
 - E = 1 (true)

Other

Inputs not connected are treated as if they did not exist.

ABB i-bus[®] KNX Parameters

7.10.26

Delay (DELAY)

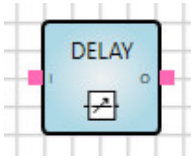

Description

Values received are forwarded after a defined delay.

Inputs

No.	DPT	Abbr.	Name	Visible	Description
1	Any	I	Input	Always	
2	4 byte signed	D	Delay	Parametrizable	Value in seconds; according to KNX DPT 13.100

Outputs

No.	DPT	Abbr.	Name	Visible	Description
1	Any	O	Output	Always	

Parameters

Name	Value	Visible	Description
Delay	Checkbox	Always	Enables input <i>D</i> (Delay)
	hh:mm:ss Default value: 00:00:00	If the checkbox is cleared	Parameter and input according to KNX DPT 13.100. Range from 00:00:00 to 99:59:59. Values outside the range are set to the minimum or maximum value respectively.

If the Delay checkbox is selected, the time value fields are not visible.

ABB i-bus[®] KNX

Parameters

Function

If a new value is received during the delay, the delay restarts and the old value is discarded.

The timer resets to zero and restarts (retrigger).

Once the delay time has elapsed, the last input value is updated to the output value.

When enabling the delay using the checkbox, note the following:

- If input *D* is not connected, the delay will automatically be set to 0.

Application examples

- Delayed transmission of scene values.
- A motion sensor is monitoring corridor lighting. As soon as the sensor detects a movement, the lighting in the corridor is gradually switched on (e.g. every 500 ms).
- Monitoring receipt of cyclical telegrams.

Bus voltage failure, download and restart

In the event of bus voltage failure, the timer stops and the input value is discarded. Therefore the output sends no value on restart.

Other

Inputs not connected are treated as if they did not exist.

ABB i-bus® KNX Parameters

7.10.27

Staircase Light (STAIRC LIGHT)



Description

A timer that automatically resets the output to 0 (false) after a specified time has elapsed.

Inputs

No.	DPT	Abbr.	Name	Visible	Description
1	1 bit	Tr	Trigger	Always	
2	4 byte unsigned	T	On-time	Parametrizable	Value in seconds; according to KNX DPT 13.100
3	1 bit	R	Retrigger	Parametrizable	1 = yes 0 = no

Outputs

No.	DPT	Abbr.	Name	Invertible	Visible	Description
1	1 bit	O	Output	Yes	Always	1 (true), as long as the timer is running

Input parameters

Name	Value	Visible	Description
On-time	Checkbox	Always	Activates input <i>T</i> (On-time)
	Unsigned integer in [s]	If the checkbox is cleared	
Retrigger	Checkbox	Always	Activates input <i>R</i> (Retrigger)
	Checkbox 2	If checkbox 1 is cleared	When the <i>Retrigger</i> input receives a value, the timer resets to 0.

If the *On-time* checkbox is selected, the time value fields are not visible. The same applies to the *Retrigger* checkbox.

ABB i-bus[®] KNX

Parameters

Function

- Input receives a 1 (true):
 - Output = 1 (true)
 - Timer restarts
- Input receives a 0 (false):
 - Output = 0 (false)
 - Timer stops
- **If the timer reaches the On-time:**
 - Output = 0 (false)
 - Timer stops
- **Retrigger:**
- If Retrigger = 1 (true):
 - When the input receives a 1 the timer restarts
- If Retrigger = 0 (false):
 - If the timer is running and the input receives a 1 (true) it ignores it. The timer continues running.

Exception handling

- If the *On-time* input is unlinked, the element uses 00:00:30.
- If the *On-time* input is negative, the element uses 00:00:00.
- If the *On-time* input has a value of 00:00:00, the output is always 0.

Bus voltage failure, download and restart

The internal timer value is saved. This value is restored on restart.

ABB i-bus[®] KNX Parameters

7.10.28

Calendar, simple (CALENDAR_S)

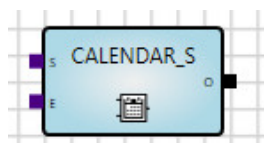

Description

Simple comparison of a start time and an end time.

Triggers daily events (for the whole day or at specific times).

The output value is 1 if the device time is between *Start* and *End* and the other conditions are met.

Inputs

No.	DPT	Abbr.	Name	Visible	Description
1	Time	S	Start	Parametrizable	
2	Time	E	End	Parametrizable	
3	1 bit	A	Active	Parametrizable	Value 0 disables the element; the output remains unchanged.
4	1 bit	WT	Whole time	Parametrizable	Output is always 1

Outputs

No.	DPT	Abbr.	Name	Visible	Description
1	1 bit	O	Output	Always	

Parameters

Name	Value	Visible	As input*
Start	Time (hh:mm:ss) Default = 00:00:00	Always	Yes
End	Time (hh:mm:ss) Default = 00:00:00	Always	Yes
Active	Checkbox	Always	Yes
Whole time	Checkbox	Always	Yes

* As input = If yes: the parameter is an input.

ABB i-bus[®] KNX Parameters

Function

- If the current time is between the start time and end time AND the Active input = 1 (true):
 - Output = 1 (true)
- Start time greater than end time:
 - Output = 0 (false)
- *Active* input = 0 (false):
 - The output remains unchanged.
- *Active* input = 1 (true):
 - The output is recalculated and updated accordingly.
- *Whole time* input = 1 (true) AND *Active* input = 1 (true):
 - Output = 1 (true)
 - The element reacts as if the start time and end time were both 00:00.

Whenever a telegram is received the output starts a recalculation independently if the value has changed.

Exception handling and startup behavior

The element does not work if:

- The system time is invalid.
- Start time or end time have invalid or no values.



Note

The function element only works with start and end time. The weekdays contained in the DPT are ignored.

ABB i-bus[®] KNX Parameters

7.10.29

Calendar (CALENDAR)



Description

Used for events that occur periodically or on specific dates. A wide variety of settings is possible.

The calendar uses the logic controller's internal clock. It can be changed via the bus (group objects).

The output value is 1 if the device time is between Start and End and the other conditions are met.

Inputs

No.	DPT	Abbr.	Name	Visible	Description
1	Time	S	Start	Parametrizable	Defines the start time; refers to corresponding parameters
2	Time	E	End	Parametrizable	Defines the end time; refers to corresponding parameters
3	1 bit	A	Active	Parametrizable	If Active = 0 the output is always 0; refers to corresponding parameters
4	1 bit	WT	Whole time	Parametrizable	If Whole time = 1, Start = 00:00:00 and End = 24:00:00; refers to corresponding parameters
5-7					Recurrence (Daily, Weekly, Monthly, Yearly); see below
8	Date	B	Begin	Parametrizable	Defines the date for activation of the Calendar element (sets a duration); before this date, the output value is 0; refers to corresponding parameters
9	Date	U	Until	Parametrizable	Defines the date for deactivation of the Calendar element (sets a duration); after this date, the output value is 0; refers to corresponding parameters

ABB i-bus[®] KNX Parameters

Daily recurrence field

No.	DPT	Abbr.	Name	Visible	Description
5	1 byte unsigned	D	Day	Parametrizable	Every ... day(s)

Weekly recurrence fields

No.	DPT	Abbr.	Name	Visible	Description
5	1 byte unsigned	D	Day	Parametrizable	Bit field input: defines the weekday(s) when the element is active. Bit 0 = Monday ... Bit 6 = Sunday
6	1 byte unsigned	W	Week	Parametrizable	Every ... week(s) on

Monthly recurrence fields

No.	DPT	Abbr.	Name	Visible	Description
5	1 byte unsigned	D	Day	Parametrizable	Day ... of every
6	1 byte unsigned	M	Month	Parametrizable	... month(s)

Yearly recurrence fields

No.	DPT	Abbr.	Name	Visible	Description
5	1 byte unsigned	D	Day	Parametrizable	Day of month
6	1 byte unsigned	M	Month	Parametrizable	Month (January – December)
7	1 byte unsigned	Y	Year	Parametrizable	Every ... year(s)

Outputs

No.	DPT	Abbr.	Name	Visible	Description
5	1 bit	O	Output	Always	

ABB i-bus[®] KNX Parameters

Parameters

The *Time* section specifies the time of day when the output has the value 1. At all other times the output has the value 0.

The *Recurrence* section specifies the days on which the element is active. On these days the output has the value 1. On all other days the output has the value 0.

Note

Recurrence *Every ... day(s), Every ...week(s) on, ...month(s), Every ...year(s)* starts on the date set in the *Duration* section.

The *Duration* section specifies the dates between which the element is active.

All the parameters can also be set via inputs. Selecting the corresponding *As input* checkbox activates the inputs.

Time section parameters

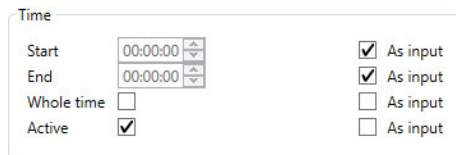

Time

Start As input

End As input

Whole time As input

Active As input

Fig. 13: Time section parameters

Parameter Name	Value	Description
Start	Time of day in minutes, default = 00:00:00	Sets the start time
End	Time of day in minutes, default = 00:00:00	Sets the end time
Whole time	1 bit, default = false (0)	Sets a whole day
Active	1 bit, default = false (0)	Activates/deactivates the element

ABB i-bus[®] KNX Parameters

Recurrence – Daily section parameters

Recurrence cycle in days.

Recurrence

Daily Every 1 day(s) As input

Weekly Every weekday

Monthly

Yearly

Fig. 14: Recurrence section parameters – Daily

Parameter Name	Value	Description
Every ... day(s)	Option 1...500, default = 1	The element is activated on specific days, e.g. every 4th day. <i>Every ... day(s)</i> and <i>Every weekday</i> are mutually exclusive options.
Every weekday	Option	See above. The element is active from Monday to Friday only.

Note

Every ... day(s) starts on the date set in the *Duration* section.

ABB i-bus® KNX Parameters

Recurrence – Weekly section parameters

Recurrence cycle in weeks.

Days of the week on which an event should be triggered every x weeks.

Recurrence

Daily Recur every week(s) on: As input
 Weekly Monday Friday As input
 Monthly Tuesday Saturday
 Yearly Wednesday Sunday
 Thursday

Fig. 15: Recurrence section parameters – Weekly

Parameter Name	Value	Description
Every ... week(s) on:	1...500, default = 1	The element is activated in specific weeks, e.g. every 3rd week.
Monday...Sunday	1 bit, default = false (0)	Parameters from <i>Monday</i> to <i>Sunday</i>

Note

Every ... week(s) starts on the date set in the *Duration* section.

ABB i-bus[®] KNX Parameters

Recurrence – Monthly section parameters

Recurrence cycle in months.

The day of the month on which an event should be triggered every x months.

Recurrence

Daily Day 1 of every As input
 Weekly 1 month(s) As input
 Monthly
 Yearly

Fig. 16: Recurrence section parameters – Monthly

Parameter Name	Value	Description
Day ... of every	1...31, default = 1	The element is activated on a specific day in a specific month, e.g. every 3rd day of the month.
... month(s)	1...500, default = 1	The element is activated in specific months, e.g. every 3rd month.

Note

... month(s) starts on the date set in the *Duration* section.

ABB i-bus[®] KNX Parameters

Recurrence – Yearly section parameters

Recurrence cycle in years.

The day of a month on which an event should be triggered every x years.

Recurrence

Daily
 Weekly
 Monthly
 Yearly

Recur every year(s) As input
 On day April As input

Fig. 17: Recurrence section parameters – Yearly

Parameter Name	Value	Description
Every ... year(s)	1...500, default = 1	The element is activated in specific years, e.g. every 3rd year.
On day ...	1...31, default = 1	See above. This defines the day of the month.
January – December	January – December	See above. This defines the month.

Note

Every ... year(s) starts on the date set in the *Duration* section.

ABB i-bus[®] KNX Parameters

Duration section parameters

Before the start date the calendar function is inactive. After the end date the calendar function is inactive.

If no end date is defined the Calendar function is active from the start date onward.

Fig. 18: Duration section parameters

Parameter Name	Value	Description
Start	Calendar day selector Default = 01.01.2016	Before this date the element is inactive.
No End	Option	<i>No End</i> and <i>End at Date</i> are mutually exclusive. Selecting <i>No End</i> activates the element indefinitely.
End at Date:	Option Calendar day selector Default = 01.01.2040	See above. After this date the element is inactive.

ABB i-bus[®] KNX Parameters

Selecting "As input"

The settings concerned are disabled and the parameters can be set via the inputs.

The screenshot displays three configuration sections for a KNX parameter:

- Time:** Contains fields for 'Start' (08:00:00) and 'End' (18:00:00), a 'Whole time' checkbox (unchecked), and an 'Active' checkbox (checked). Each field has a corresponding 'As input' checkbox, all of which are checked.
- Recurrence:** Features radio buttons for 'Daily', 'Weekly' (selected), 'Monthly', and 'Yearly'. A 'Recur every' field is set to '1' week(s). Days of the week (Monday through Sunday) are listed with checkboxes, all of which are unchecked. Each day has a corresponding 'As input' checkbox, all of which are checked.
- Duration:** Includes 'Start' and 'End' date fields, both set to '01.01.1990'. The 'End' section has radio buttons for 'No End' (unchecked) and 'End at Date' (checked). Each date field has a corresponding 'As input' checkbox, all of which are checked.

Fig. 19: Selecting "As input"

Startup behavior

The element will not be active unless a valid date and/or time are provided via the *Start* and *End* fields.

ABB i-bus[®] KNX Parameters

7.10.30

Numeric Converter (N-CONV)

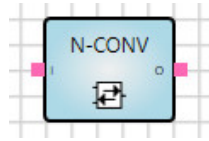

Description

The converter allows you to link different datapoint types and convert them.

Basics on datapoint types

The KNX specification distinguishes between main datapoint types and sub types, e.g.:

Main DPT type	DPT sub type	DPT name
1.xxx	1.001	DPT_SWITCH
	1.008	DPT_UPDOWN
	1.100	DPT_HEAT/COOL

Main type: Defines a data width.

Subtype: Defines a data width and unit.

Application

- Conversion between different units of measurement, e.g. °C and °F or m/s and km/h
- Conversion between different data types and widths
- Conversion between a 2-byte float and a 4-byte float (e.g. temperature values)

Function

The following data types can be converted:

Data type	KNX Data Type
1 byte unsigned	5.xxx
1 byte signed	6.xxx
2 byte unsigned	7.xxx
2 byte signed	8.xxx
2 byte float	9.xxx
4 byte unsigned	12.xxx
4 byte signed	13.xxx
4 byte float	14.xxx

ABB i-bus[®] KNX Parameters

Inputs

No.	DPT	Abbr.	Name	Visible	Description
1	See above	I	Input	Always	
2	See above	F	Factor	Parametrizable	
3	See above	O	Offset	Parametrizable	

Outputs

No.	DPT	Abbr.	Name	Visible	Description
1	See above	O	Output	Always	

Parameters

Name	Value	Visible	Description
Factor	Single Float	Always	Enables <i>Factor</i> input
Offset	Single Float	Always	Enables <i>Offset</i> input

Calculation

- The output is calculated as $\text{input} * \text{Factor} + \text{Offset}$.
- If the output result is greater than the data type concerned: the maximum for the data type is applied to the output.
- If the output result is less than the data type concerned: the minimum for the data type is applied to the output.

The N-CONV element can be used to divide a 2-byte unsigned value into an upper and lower byte.

- The lower value is calculated using $\text{Factor} = 1$.
- The unsigned upper 2-byte value is calculated using $\text{Factor} = 0.00390625 (= 1/256)$.
- The unsigned upper 4-byte value is calculated using $\text{Factor} = 0.0000152587890625 (= 1/65536)$.
- The conversion of a 1-byte unsigned value from a value range 0...255 into 0...100 is calculated using $\text{Factor} = 0.00390625$.

Other

Inputs not connected are treated as if they did not exist.

ABB i-bus[®] KNX Parameters

7.10.31

RS Flip Flop (RS-FF)

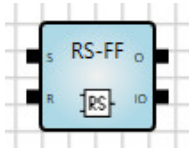

Description

Stores input states and resets them on request.

Inputs

No.	DPT	Abbr.	Name	Visible	Description
1	1 bit	S	Set	Always	A value of 1 sets the Flip Flop output to 1.
2	1 bit	R	Reset	Always	A value of 1 resets the Flip Flop output to 0 and disables it.

Outputs

No.	DPT	Abbr.	Name	Visible	Description
1	1 bit	O	Output	Always	Flip Flop output status
2	1 bit	IO	Inverted Output	Always	Inverted Flip Flop output status

Parameters

Initial value:

Initial value of the input. Can only be used in combination with the *Set initial value after restart* parameter.



Note

Selecting the checkbox sets the initial value to 1, but only with 1-bit values. Clearing the checkbox (default) sets the initial value to 0.

Set initial value after restart:

The initial value is used after a restart.



Note

After a restart, either the initial values are used or the input values are restored, or the system waits for a telegram to arrive. In the first two cases, the logic function is not recalculated.

ABB i-bus[®] KNX Parameters

Function

Use of Flip Flop e.g. as an alarm memory.

No output value is actively set on the output.

Any initial values set can trigger an output change when the inputs receive an incoming signal.

O	S	R	O new
0	0	0	0
0	0	1	0
0	1	0	1
0	1	1	0
1	0	0	1
1	0	1	0
1	1	0	1
1	1	1	0

Note

As long as input R = 1, the output is always 0.

Bus voltage failure, download and restart

The values are stored. The last output value is restored on restart.

ABB i-bus[®] KNX Parameters

7.10.32

Up Counter (UP COUNT)

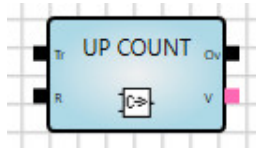

Description

Counts upward from 0 to an adjustable threshold. Only counts value changes from 0 to 1.

Inputs

No.	DPT	Abbr.	Name	Visible	Description
1	1 bit	Tr	Trigger	Always	Trigger input. Value change from 0 to 1 increments the counter by 1.
2	1 bit	R	Retrigger	Always	0 = counter counts 1 = resets the counter to 0 and disables it
3	8 bit or higher	Th	Threshold	Parametrizable	Counter threshold. Reaching this threshold triggers an overflow at the output.

Outputs

No.	DPT	Abbr.	Name	Visible	Description
1	8 bit or higher	V	Value	Always	Counter value, integer
2	1 bit	Ov	Overflow	Always	Counter threshold reached

Parameters

Name	Value	Visible	Description
Threshold	Integer value. Same data type as the counter value.	Always	Selecting the corresponding checkbox activates the <i>Threshold</i> input.

ABB i-bus[®] KNX

Parameters

Function

- The counter increments on a change of value from 0 to 1 (rising edge).
- The counter counts upward from 0 to an adjustable threshold. If the threshold is reached the counter stops and the *Overflow* output receives a value 1 (true) on the next rising edge.
- *Reset* input:
 - Value 0: The counter counts upwards.
 - Value 1: Resets the counter to 0 and disables it. The output value is 0.
- *Threshold* input:
 - Defines the counter threshold.
 - Can only be entered if the Output value is connected.

Bus voltage failure, download and restart

The counter value is saved. The output value is restored on restart. The output value is updated the first time the counter value changes after restart.

Application examples

- Telegram counter: counts the number of telegrams received (usage of *Telegram received* used on the KNX input).
- Pulse counter for energy values: calculates the energy consumption.
- Event counter: an alarm is triggered if three events occur within one minute.

ABB i-bus[®] KNX Parameters

7.10.33

PID controller (PID)

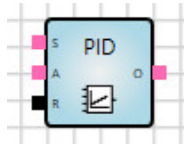

Description

The PID-Controller calculates the output value from the difference between the *Setpoint* and the *Actual Value*. The control parameters are proportional coefficient, integral time and derivative time.

Inputs

No.	DPT	Abbr.	Name	Visible	Description
1	Numerical, 1 byte or higher	S	Setpoint	Always	Target value of controller, e.g. target room temperature
2	Same as Input 1	A	Actual value	Always	Current measured value
3	Numerical, 1 byte or higher	PC	Proportional coefficient	Parametrizable	Controller gain
4	Numerical, 1 byte or higher	IT	Integral time	Parametrizable	Integral time in [s]; typical range: 60...900 s $C_i = 1/\text{Integral Time}$
5	Numerical, 1 byte or higher	DT	Derivative time	Parametrizable	Derivative Time in [s]; typical range: 1...10 s $C_d = \text{Derivative Time}$
6	1 bit	R	Reset	Always	Triggers the integral element in the controller. As long as $R = 0$ the integral value is set to 0.

Outputs

No.	DPT	Abbr.	Name	Visible	Description
1	Numerical, 1 byte or higher	O	Output	Always	Control value, no unit. Typically 1 byte unsigned (0...255)

Room temperature control example:

The *Setpoint* and *Actual Value* are two temperatures. The output value is the control value of a valve actuator.

ABB i-bus[®] KNX Parameters

Parameters

Name	Value	Visible	Description
Controller type	- <u>P</u> roportional (P) - Integral (PI) - Derivative (PD) - PID	Always	
Proportional coefficient	Float value, default = 60	Always	
Integral time	Float value in [min], default = 90, 0 not permitted	If <i>Controller type</i> = PI or PD	Integral time in [s]; typical range: 60...900 s
Integral time as input	- <u>y</u> es - <u>n</u> o	If <i>Controller type</i> = PI or PD	
Derivative time	Float value in [s], default = 1	If <i>Controller type</i> = PD or PID	Derivative time in [s]; typical range: 1...10 s
Derivative time as input	- <u>y</u> es - <u>n</u> o	If <i>Controller type</i> = PD or PID	
Limit output value, anti-wind-up	- <u>y</u> es - <u>n</u> o	Always	Limits the output value to a range. If this range is exceeded, a limit is imposed on the integral element in the controller ("anti-wind-up").
Lower limit	Float value, default = 0	Always	
Upper limit	Float value, default = 255	Always	

Description of parameters

Controller type:

Value	Description
P (Proportional)	Proportional controller. The integral and derivative coefficients are 0.
PI (Integral)	Proportional integral controller. The derivative coefficient is 0.
PD (Derivative)	Proportional derivative controller. The integral coefficient is 0.
PID	Proportional integral derivative controller.

If the controller type is P (Proportional), the integral value and derivative value are always 0.

ABB i-bus[®] KNX Parameters

Function

Schematic diagram of controller:

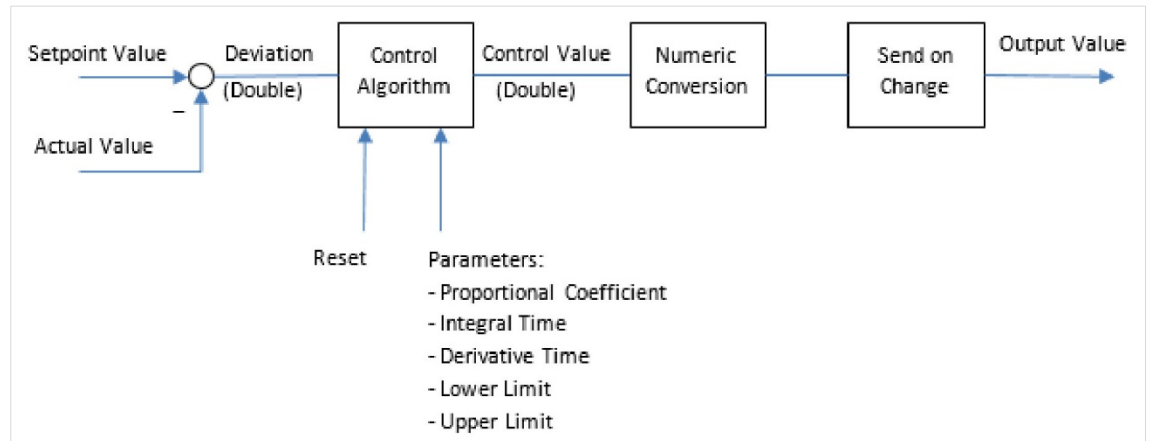

Fig. 20: Schematic diagram of controller

Algorithms:

- $ControlValue = ProportionalValue + IntegralValue + DerivativeValue$
- $ProportionalValue = Deviation \times ProportionalCoefficient$
- $IntegralValue = IntegralValueOld + Deviation \times CycleTime / IntegralTime$
- $DerivativeValue = (Deviation - DeviationOld) / CycleTime \times DerivativeTime$

The controller calculates a new output value during the calculation cycle time of the logic engine (see [Cycle time](#)) (usually every 200 ms). The output sends on value change.

If the ControlValue exceeds the *Upper limit* or *Lower limit* (see parameters), the values are limited accordingly and the IntegralValue is reduced.

If the Reset input = 1: the IntegralValue is set to 0.

Exceptions

For parameter inputs (Proportional coefficient, Integral time, Derivative time) not connected, the function element uses the value 0.

Bus voltage failure, download and restart

The integral value is saved. The value is restored on restart.

ABB i-bus[®] KNX Parameters

7.10.34

Constant (CONST)

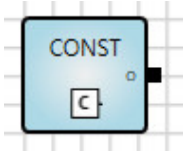

Description

The constant can be used, for example, for the purposes of comparison with other input variables. The constant never triggers a recalculation.

Outputs

No.	DPT	Abbr.	Name	Visible	Description
1	Any	O	Output	Always	

Parameters

Name	Value	Visible	Description
Constant Value	According to DPT	Always	For entering a constant value. Selecting the checkbox sets the initial value to 1, but only with 1-bit values. Deselecting it sets a value of 0.

ABB i-bus[®] KNX Parameters

7.10.35

Website Input (WEB IN)

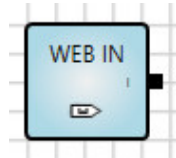

Description

Generates an input value on the web browser ("WebUI").

On the use of this element, a corresponding entry for value input is added to the WebUI. Values entered are forwarded to the logic.

Outputs

No.	DPT	Abbr.	Name	Visible	Description
1	Any	I	In	Always	Sends the value entered in the WebUI.

Parameters

Name	Value	Visible	Description
Min Value	According to DPT	Always	Minimum value that can be entered in the WebUI.
Max Value	According to DPT	Always	Maximum value that can be entered in the WebUI.
Index	Integer	Always	Defines the order in which the input values are displayed on the WebUI. Small values displayed on top.

Function

The element name is applied as the description text on the web user interface.

ABB i-bus[®] KNX Parameters

7.10.36

Website Output (WEB OUT)

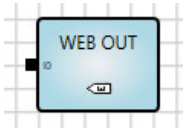

Description

Generates an output value on the web browser (web user interface). This value is read-only.

Inputs

No.	DPT	Abbr.	Name	Visible	Description
1	Any	IO	Out	Always	Displayed value

Parameters

Name	Value	Visible	Description
Index	Integer	Always	Defines the order in which the input values are displayed on the WebUI. Small values displayed on top.

Function

The element name is applied as the description text on the web user interface.

ABB i-bus[®] KNX Parameters

7.10.37

Function Block Input (FB IN)

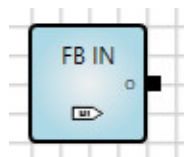

Description

Input for a user-defined function block. If you wish to use the same logic several times, you can combine and save it in a function block. In this case the function block input is used instead of a KNX input.

Outputs

No.	DPT	Abbr.	Name	Visible	Description
1	Any	O	Output	Always	

Parameters

Name	Value	Visible	Description
Short description	According to DPT	Always	Default: I
Full description	According to DPT	Always	Default: In
Index	According to DPT	Always	Default: 0

ABB i-bus[®] KNX Parameters

7.10.38

Function Block Output (FB OUT)

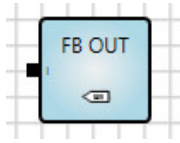

Description

Output for a user-defined function block. If you wish to use the same logic several times, you can combine and save it in a function block. In this case the function block output is used instead of a KNX output.

Outputs

No.	DPT	Abbr.	Name	Visible	Description
1	Any	I	Input	Always	

Parameters

Name	Value	Visible	Description
Short description	According to DPT	Always	Default: 0
Full description	According to DPT	Always	Default: Out
Index	According to DPT	Always	Default: 0

ABB i-bus[®] KNX Parameters

7.10.39 Composite function blocks

If you wish to use the same logic function several times, you can combine and save it in a composite function block.

How to create a composite function block:

- Create a logic engine with "normal" KNX inputs and outputs, and use Simulation to check that it is working.
- Copy the logic and replace the KNX inputs and outputs with function blocks FB IN and FB OUT for the same data type.
- Enter the following parameters for function blocks FB IN and FB OUT:
 - Short description: One or more letters shown at the function block I/O.
 - Full description: Name of the function block when you mouse over it.
 - Index: The number of the I/O. This must be unique.

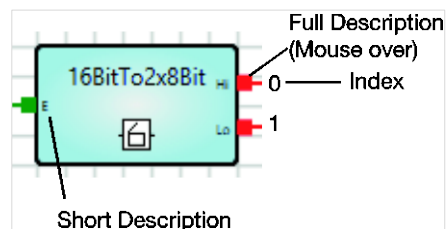
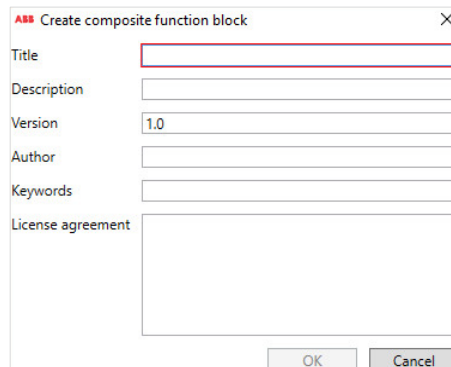

Fig. 21: Composite function blocks – description

- Highlight the entire logic and select *Edit > Create composite block*.

ABB i-bus[®] KNX Parameters

- The following dialog window appears:



The dialog window titled "Create composite function block" contains the following fields:

- Title:
- Description:
- Version:
- Author:
- Keywords:
- License agreement:

Buttons: OK, Cancel

Fig. 22: Creating composite function blocks

Enter the data saved with the function block. The title must be unique.

- Click OK.

The composite function block is now stored and recallable in *Own function blocks* on the left in the Element Selector window.

ABB i-bus[®] KNX Parameters

Exporting composite function blocks:

- Select the composite function block in *Own function blocks*.



Fig. 23: Exporting own function blocks

- Select Export function block.
- The following dialog window appears:

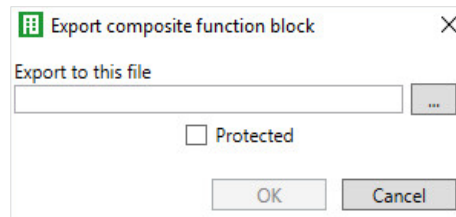

Fig. 24: Own function blocks - destination file

Enter a name for the destination file.

Enabling the *Protected* option encrypts the destination file.

Importing composite function blocks:

Select File > *Import composite function block*.

Note

Inverting the outputs of composite function blocks currently has no effect.
Composite function blocks cannot be linked to internal markers.

ABB i-bus[®] KNX Parameters

7.10.40 **Comment**

ABC

The Comment element can be saved with a logical link in order to explain it.

You can adjust the angle of rotation, width and height by dragging and dropping with the left-hand mouse button, or in the Properties window.

7.10.41 **Rectangle**



The Rectangle element can be used to organize things more clearly, for example by framing a logical link.

You can adjust the angle of rotation, width and height by dragging and dropping with the left-hand mouse button, or in the Properties window.

7.10.42 **Line**



The Line element can be used to organize things more clearly.

You can adjust the angle of rotation, width and height by dragging and dropping with the left-hand mouse button, or in the Properties window.

ABB i-bus[®] KNX

Group objects

8 Group objects

8.1 Summary of group objects

No.	Object Function	Name	DPT	Length	Flags				
					C	R	W	T	U
1...500	Applied from the logic editor	Blank	Configuration-dependent	Configuration-dependent	X	X	X	X	
501	In operation	General	1,001	1 bit	X				X
502	Request object	Device Clock	1,017	1 bit	X				X
503	Date	Device Clock	11,001	3 byte	X	X	X		
504	Time	Device Clock	10,001	3 byte	X	X	X		
505	Date/Time	Device Clock	19,001	8 byte	X	X	X		

Table 7: Summary of group objects

ABB i-bus[®] KNX

Group objects

8.2 Inputs and outputs

No.	Object Function	Name	Data type	Flags
1...500	Applied from the logic editor	Blank	According to the definition in the logic editor	C, R, W, T
This group object is defined via the logic editor. Unique names can be entered in the logic editor <i>Properties</i> window.				

Table 8: Inputs and outputs

8.3 Time synchronization

No.	Object Function	Name	Data type	Flags
501	In operation	General	1 bit DPT 1.001	C, T
For a description, see Send Group Object "In Operation" (1-bit)				
502	Request object	Device Clock	1 bit DPT 1.017	C, T
This group object queries the date/time from a time master after device start-up. 30 seconds after start-up this group object will send a 1.				
503	Date	Device Clock	3 byte DPT 11.001	C, R, W
This group object receives the date.				
504	Time	Device Clock	3 byte DPT 10.001	C, R, W
This group object receives the time. Only time information is evaluated. Day of the week information is not taken into account.				
505	Date/Time	Device Clock	8 byte DPT 19.001	C, R, W
This group object receives the combined date and time. Only date and time is evaluated. Other information provided by this datapoint (e.g. year or weekday) is not taken into account.				

Table 9: Time synchronization

ABB i-bus[®] KNX

Operation

9 **Operation**

9.1 **Manual operation**

Not relevant for this device.

ABB i-bus[®] KNX

Maintenance and cleaning

10 Maintenance and cleaning

10.1 Maintenance

The device is maintenance-free. In the event of damage (e.g. during transport and/or storage), do not carry out any repairs.

10.2 Cleaning

The voltage supply to the device must be switched off before cleaning. If devices become dirty, they can be cleaned using a dry cloth or a cloth dampened with a soapy solution. Never use corrosive agents or solutions.

ABB i-bus[®] KNX

Disassembly and disposal

11 Disassembly and disposal

11.1 Removal

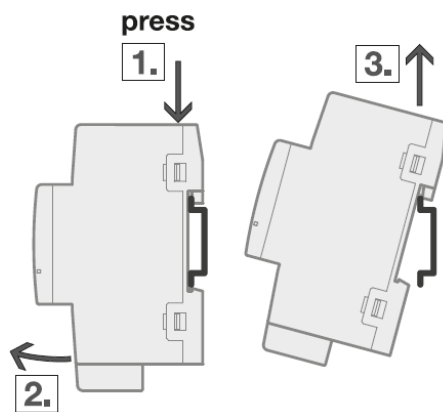

Fig. 25: Removal

1. Press on the top of the device.
2. Release the bottom of the device from the DIN rail.
3. Lift the device up and off the DIN rail.

2CDC072012F0015

11.2 Environment

Consider environmental protection.

Used electrical and electronic devices must not be disposed of as domestic waste.



The device contains valuable resources that can be recycled. Therefore, please bring the device to a suitable recycling center. All packaging materials and devices are provided with markings and test seals for proper disposal. Always dispose of packaging material and electrical devices or their components at collection points or disposal companies authorized for this purpose. The products comply with the statutory requirements, particularly the law on electrical and electronic equipment and the REACH regulation. (EU directive 2012/19/EU WEEE and 2011/65/EU RoHS) (EU REACH regulation and the law implementing the regulation (EC) no.1907/2006)

12 **Planning and application**

Not relevant for this device.

13 Appendix

13.1 Scope of delivery

The logic controller is supplied together with the following components. The delivered items should be checked against the list below:

- 1x Logic Controller ABA/S 1.2.1
- 1x installation and operating instructions
- 1x bus connection terminal (red/black)
- 1x KNX connection cover cap

ABB i-bus[®] KNX

Appendix

13.2 Notes

ABB i-bus[®] KNX

Appendix

Notes



ABB STOTZ-KONTAKT GmbH
Eppelheimer Straße 82
69123 Heidelberg, Germany
Tel.: +49 (0)6221 701 607
Fax: +49 (0)6221 701 724
Email: knx.marketing@de.abb.com

**Further information and
local contacts**
www.abb.com/knx

© Copyright 2019 ABB. We reserve the right to make technical changes or modify the contents of this document without prior notice. The agreed properties are definitive for any orders placed. ABB AG accepts no responsibility whatsoever for potential errors or possible lack of information in this document. We reserve all rights in this document and in the subject matter and illustrations contained therein. Reproduction, transfer to third parties or processing of the content – including sections thereof – is not permitted without the prior written consent of ABB AG.